

CIRCULATION LARGER THAN ANY OTHER RADIO PUBLICATION

# RADIO NEWS

REG. U.S. PAT. OFF.

25 Cents  
September

1923

Over 200 Illustrations

Edited by H. GERNSBACK

## THE RADIO GUN

See Page 250

### IN THIS ISSUE

ARTICLES BY

SIR OLIVER LODGE, D.Sc.; LL.D.; F.R.S.

DR. J. A. FLEMING, M.A.; D.Sc.; F.R.S.

JOHN SCOTT TAGGART, F. INST. P.

ELLIS PARKER BUTLER

\$300.-PRIZE CONTEST

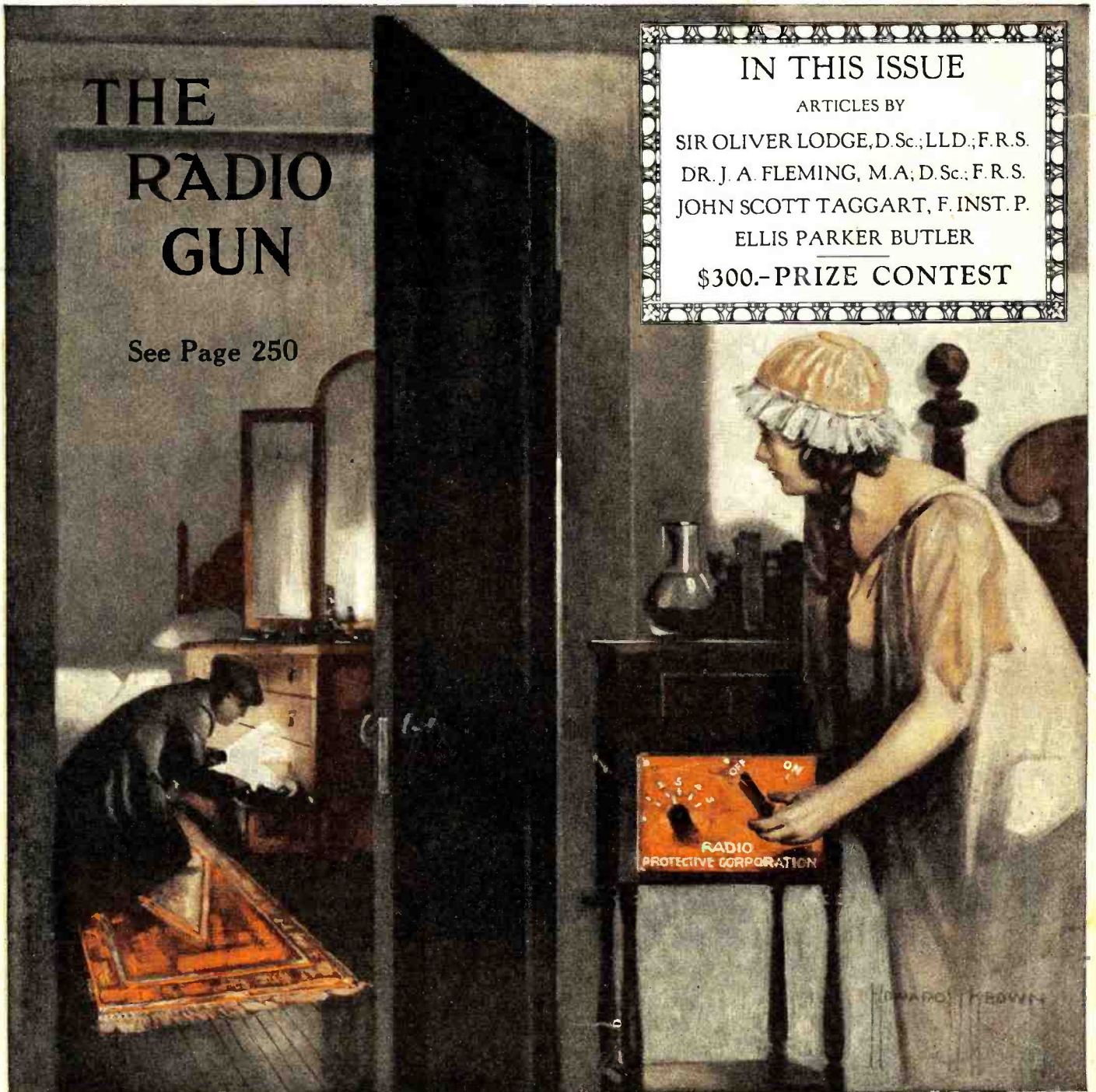

THE 100% WIRELESS MAGAZINE



## The Ideal Tube For the Call of the Open

Are you spending your vacation in the North Woods—at the seashore—in one of our many great national parks, or are you motoring across country? In any event the new Cunningham dry battery detector and amplifier, type C-299, makes it possible for you to take a radio receiver, which will be light in weight, compact in design, and highly efficient in operation. It is the special filament in this tube, having a current so low that it may receive its supply from standard No. 6 dry batteries or even from ordinary flashlight batteries, that makes possible this new and interesting application of radio.

The receiving set you now have can be readily adjusted to use this new tube and be a source of use and pleasure on your vacation trip. In any event your dealer can give you useful suggestions for the purchase or construction of a highly efficient and practical portable set.

*A Specially  
Designed Tube  
For Every  
Radio Use*

**Patent Notice:** *Cunningham tubes are covered by patents dated 11-7-05, 1-15-07, 2-18-08, and others issued and pending. Licensed for amateur, experimental and entertainment use in radio communication. Any other use will be an infringement.*

*E. J. Cunningham Inc.*

**Home Office:**  
248 First Street  
San Francisco, Calif.

**Eastern Representatives**  
154 W. Lake St.  
Chicago, Ill.

Announcing the Greatest  
Improvements Yet Made in  
Radio Reception—

# New Erla Reflex Circuits Using 2 and 3 Tubes



Unequaled range and power over a waveband of 200 to 900 meters, are assured by Erla radio transformers. AB 1,2,3, \$4. Reflex 1,2, \$5



Exclusive telescoping rim of Erla bezels fits any 1/8" to 1/4" panel. Made in bright nickel or dull enamel, in 1" and 1 1/2" sizes. List, 20c



Erla is the only fixed condenser guaranteed to test to the exact capacity for which it is marked. Made in eleven sizes, 35c to \$1 each



Present types of detectors are antiquated by the new Erla crystal rectifier. No adjustment required. Proof against jolt or jar. List, \$1

Tube for tube, the new Erla two and three-tube reflex circuits demonstrate a degree of efficiency never heretofore attained. The most elaborate six and seven-tube circuits fail to duplicate their range and volume.

Constructed on the same fundamental principle as the famous Erla Duo-Reflex circuit, the most powerful single-tube circuit ever built, they record a tremendous advance in radio apparatus construction.

With the three-tube circuit, nation-wide reception is obtained through a loud speaker, and the two-tube circuit is but a step behind. Either circuit is operated successfully with an indoor antenna, while current consumption is so low that dry cells can be advantageously employed.

Guaranteeing the successful operation of these circuits, and the keystone of their amazing range and power, are Erla synchronized radio reflex and audio reflex transformers. Through their employment, the difficulties experienced until now with reflex circuits are entirely overcome, assuring absolute stability, with unequaled purity, sensitiveness and amplification.

Further improvement results from the use of the new Erla fixed crystal detector, designed especially for reflex work. No adjustment is required with this crystal, and it is proof against jolt and jar, giving perfect rectification at all times.

Complete diagrams and descriptions of Erla one, two and three-tube reflex circuits are presented in Erla Bulletin No. 14, with instructions for installing. Ask any leading radio dealer, or write us, giving your dealer's name.



Perfect synchronization and standardization of Erla audio transformers guarantees success in reflex work. Ratios—3 1/2 and 6 to 1. List, \$5



Unmatched beauty of finish and workmanship gives first place to Erla sockets. All parts triply nickeled. Polished Radion base. \$1



Two sets of headphones are handled simultaneously by Erla phone plugs, built to superior Erla standards in workmanship and finish. 75c

**JOBBERS**—Erla research facilities maintain Erla products at the forefront of radio development, assuring maximum sales and profits. Write for our liberal terms and discounts

**Electrical Research Laboratories**  
Dept. C 2515 Michigan Avenue, Chicago

# ERLA

TRADE MARK REGISTERED



# RADIO NEWS



## CONTENTS

VOL. 5

FOR SEPTEMBER

No. 3

|   | Page |   | Page |
|---|------|---|------|
| Editorial   | 241  | Naval, Commercial and Amateur Radio   | 259  |
| What Secretary Wallace Thinks About Radio.<br>By J. Farrell                           | 242  | Radio Public Impatient With Advertising Talks   | 259  |
| The Radio Amateur in a New Field.<br>By Herbert H. Foster                             | 243  | The McNoodle Brothers' Radio Mystery<br>By Ellis Parker Butler                          | 260  |
| The First College Radio Club.<br>By Robert F. Gowen                                   | 244  | Proper Antenna for Tuning   | 261  |
| Radio Telephony for Rural Districts.<br>By Captain H. W. Webbe                        | 246  | \$300 Prize Contest Announcement  | 261  |
| Pittsburgh Church Unveils Tablet Given by Un-<br>seen Radio Congregation              | 247  | A Super-Sensitive Two-Tube Receiver.<br>By John Scott-Taggart                           | 262  |
| Radio Pays its Debt to E. J. Alexanderson   | 247  | Detection—Part II<br>By Louis Frank   | 263  |
| An Aspect of the Future of Broadcasting.<br>By Jesse Marsten                          | 248  | Electrons, Electric Waves and Wireless Tele-<br>phony—Part VIII<br>By Dr. J. A. Fleming | 264  |
| Radio Control in Great Britain  | 248  | Multi-Layer Coils<br>By G. P. Kendall   | 268  |
| Pioneer Work in Ether Waves.<br>By Sir Oliver Lodge                                   | 249  | Continuous Wave and Radiophone Transmitters—<br>Part I<br>By L. R. Felder               | 270  |
| The Radio Gun<br>By Aubra R. Dunham   | 250  | Selection of Vacuum Tubes   | 272  |
| Radio Pictorial   | 251  | Facts About DX Crystal Reception  | 273  |
| General Harbord Explains the Patent Situation   | 252  | With the Amateurs   | 274  |
| Commercial Radio Installations  | 253  | Radio to Play Important Part in Polar Expedition  | 275  |
| Summertime Radio  | 254  | The All-Purpose Receiver<br>By M. B. Sleeper  | 276  |
| Foreign Radio Broadcasting  | 255  | The Modified Reinartz Receiver.<br>By Maurice L. Muhleman                               | 278  |
| Broadcasting and the Swedish Telegraph Depart-<br>ment<br>By Our Berlin Correspondent | 255  | An Inductance Variometer—A Utility Radio Unit.<br>By Six Zee Jay                        | 279  |
| Radio Novelties   | 256  | Awards of the C. W. and Phone Contest   | 280  |
| A Radio Live Wire   | 256  | Awards of the \$50 Radio Wrinkle Contest  | 282  |
| Radio Exhibition in Tokio   | 257  | Definition of Radio Terms   | 284  |
| Recent Radio Exhibitions  | 258  | Correspondence from Readers   | 285  |
|   |      | Radio News Laboratories   | 286  |
|   |      | Pointers for Would Be Operators.<br>By Frank Mayer                                      | 288  |
|   |      | I Want-To-Know  | 289  |
|   |      | Index to Advertisers  | 236  |

RADIO NEWS is published on the 10th of each month. There are 12 numbers per year. Subscription price is \$2.50 a year in U. S. and possessions. Canada and foreign countries, \$3.00 a year. U. S. coin as well as U. S. Stamps accepted (no foreign coins or stamps). Single copies, 25 cents each. A sample copy will be sent gratis on request. Checks and money orders should be drawn to order of EXPERIMENTER PUBLISHING CO., INC. If you should change your address notify us promptly, in order that copies be not miscarried or lost. No copies sent after expiration.

All communications and contributions to this journal should be addressed to Editor, RADIO NEWS, 812 Jamaica Avenue, Jamaica, New York; or 53 Park Place, New York, N. Y. Unaccepted contributions cannot be returned unless full postage has been included. All accepted contributions

are paid for on publication. A special rate is paid for novel experiments, good photographs accompanying them are highly desirable.

RADIO NEWS, Monthly. Entered as second-class matter at the Post Office at Jamaica, N. Y., under the act of March 3, 1897. Title registered U. S. Patent Office. Copyright, 1921, by E. P. Co., Inc., New York. The Experimenter Publishing Co., 53 Park Place, N. Y. The contents of this magazine are copyrighted and must not be reproduced without giving full credit to the publication.

RADIO NEWS is for sale at all newsstands in the United States and Canada; also at The International News Co., Ltd., Bream's Building, London E. C. 4, England, and at Brentano's 37 Avenue de l'Opera, Paris.

General Advertising Dept., 53 Park Place, New York City. Western Advertising Representatives, Finucan & McClure, 720 Cass Street, Chicago, Ill. Kansas City Representative, Geo. F. Dillon, Republic Bldg., Kansas City, Mo. Pacific Coast Advertising Representatives, A. J. Norris Hill Co., Hearst Bldg., San Francisco, Cal.

Published by EXPERIMENTER PUBLISHING CO., INC.,  
Publishers of "Radio News," "Science and Invention" and "Practical Electrics."  
Publication Office: Jamaica, N. Y. Editorial and General Offices: 53 Park Place, New York City  
H. GERNSBACK, President S. GERNSBACK, Treasurer R. W. DEMOTT, Secretary

“Dimensions are limitless; time is endless.” *Chuang Tzu*—

The Wise man conquers the barriers of time and space with the New **GREBE**

Broadcast Receiver —

*Doctor Mfg.*

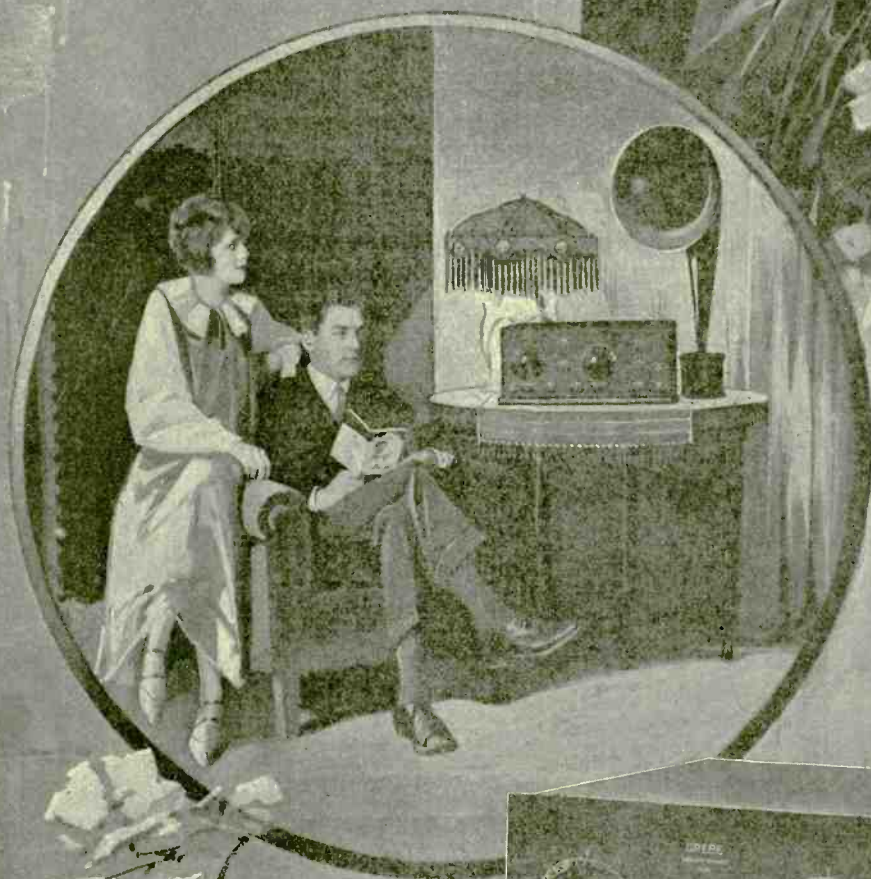

Receive all broadcasting without outdoor antenna, loop, or storage battery!

This Receiver employs Regeneration and Tuned Radio Frequency Amplification with only two simple tuning adjustments.

Write for “Seven Points of Satisfaction”

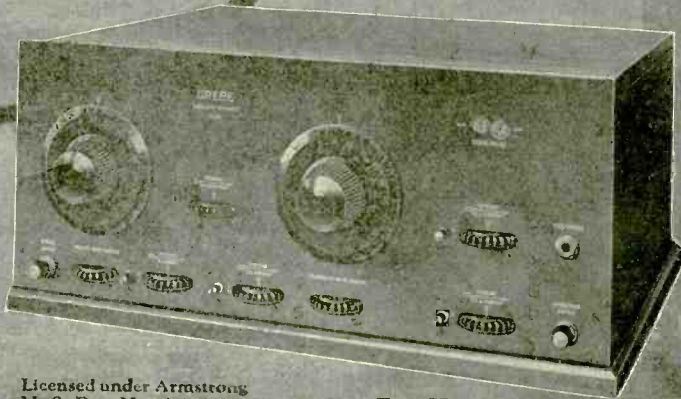

A. H. GREBE & COMPANY, Inc.  
Richmond Hill, N.Y.  
Western Branch, 451 East 3rd St., Los Angeles, Cal.

Licensed under Armstrong  
U. S. Pat. No. 1,113,149

Type CR-12

# Index to Advertisers

| A                                     | Page | E                                  | Page | L   | Page | Page                                 |     |
|---------------------------------------|------|------------------------------------|------|---|------|--------------------------------------|-----|
| Acme Apparatus Company                | 299  | E. I. Company, The                 | 303  | L. S. R. Electric Mfg. Co.                    | 336  | Radio Specialty Co.                  | 315 |
| Airway Electric Appliance Corp.       | 322  | Eisemann Magneto Corp.             | 344  | Lacey & Lacey                                 | 350  | Radio Stores Corp.                   | 354 |
| Aitken Radio Co.                      | 318  | Electrical Research Labs.          | 233  | Lambert, Leon                                 | 310  | Radio Tube Exchange                  | 349 |
| Alden Mfg. Co.                        | 342  | Electric Specialty Co.             | 320  | Lancaster & Allwine                           | 350  | Randell Wireless                     | 336 |
| Allen-Bradley Co.                     | 297  | Electric Storage Battery Co., The  | 240  | LeFax, Inc.                                   | 294  | Randolph & Co.                       | 348 |
| Allied Factories Corp.                | 310  | Engravers & Printers Machinery Co. | 304  | Leich Electric Co.                            | 318  | Rasla Sales Corp.                    | 338 |
| American Bell Radio Corp.             | 344  | Ernest Electric Co.                | 308  |   |      | Rauland Mfg. Co.                     | 355 |
| American Hard Rubber Co.              | 321  | Evans & Co., Victor J.             | 348  | <b>M</b>                                      |      | Remler Radio Mfg. Co.                | 343 |
| American Transformer Co.              | 324  | Experimenters' Information Service | 317  | M. P. M. Sales Co.                            | 329  | Reynolds Radio Co.                   | 306 |
| Amsterdam Service Exchange            | 314  |                                    |      | Magnavox Company, The                         | 307  | Rhamstine, J. Thos.                  | 332 |
| Andrae & Sons Co., Julius             | 343  |                                    |      | Marko Storage Battery Co.                     | 312  | Riggs Mfg. Co., The                  | 346 |
| Andrea, Inc., F. A. D.                | 316  |                                    |      | Marshall Gerken Co., The                      | 339  | Rose Radio Supply                    | 298 |
| Atwater Kent Mfg. Co.                 | 318  |                                    |      | Martin-Copeland Co.                           | 323  | Rusonite Products Corp.              | 335 |
| Automatic Electrical Devices Co., The | 344  |                                    |      | Massachusetts Radio & Telegraph Schools, Inc. | 324  |                                      |     |
| Autoyre Company, The                  | 340  |                                    |      | Michigan Radio Corp.                          | 346  | <b>S</b>                             |     |
|                                       |      |                                    |      | Midwest Radio Co., The                        | 330  | Sadler Mfg. Co.                      | 332 |
|                                       |      |                                    |      | Mitchell & Co., R.                            | 322  | Saturn Mfg. & Sales Co., Inc., The   | 312 |
|                                       |      |                                    |      | Montgomery Ward & Co.                         | 355  | Service Radio Co.                    | 334 |
|                                       |      |                                    |      | Montrose Mfg. Co.                             | 342  | Shipman-Ward Mfg. Co.                | 342 |
|                                       |      |                                    |      | Motor Boating                                 | 336  | Signal Electric Mfg. Co.             | 306 |
|                                       |      |                                    |      | Multiple Electric Products Co., Inc.          | 357  | Simplex Radio Co.                    | 332 |
|                                       |      |                                    |      | Mu-Rad Laboratories, Inc.                     | 339  | Stromberg-Carlson Telephone Mfg. Co. | 308 |
|                                       |      |                                    |      |   |      |                                      |     |
|                                       |      |                                    |      |   |      | <b>T</b>                             |     |
|                                       |      |                                    |      |   |      | Telephone Maintenance Co.            | 353 |
|                                       |      |                                    |      |   |      | Tresco                               | 337 |
|                                       |      |                                    |      |   |      | True-Tone Radio Mfg. Co.             | 341 |
|                                       |      |                                    |      |   |      | Tuska Co., The C. D.                 | 215 |
|                                       |      |                                    |      |   |      | Twitchell, S. A.                     | 324 |
|                                       |      |                                    |      |   |      |                                      |     |
|                                       |      |                                    |      |   |      | <b>U</b>                             |     |
|                                       |      |                                    |      |   |      | Union Construction Co.               | 334 |
|                                       |      |                                    |      |   |      | United Mfg. & Distributing Co.       | 324 |
|                                       |      |                                    |      |   |      |                                      |     |
|                                       |      |                                    |      |   |      | <b>V</b>                             |     |
|                                       |      |                                    |      |   |      | V-De-Co Radio Mfg. Co.               | 338 |
|                                       |      |                                    |      |   |      | Valley Electric Co.                  | 346 |
|                                       |      |                                    |      |   |      | Veritas, M.                          | 350 |
|                                       |      |                                    |      |   |      | Vesco Radio Shop                     | 316 |
|                                       |      |                                    |      |   |      |                                      |     |
|                                       |      |                                    |      |   |      | <b>W</b>                             |     |
|                                       |      |                                    |      |   |      | Walart Electric Mfg. Co.             | 340 |
|                                       |      |                                    |      |   |      | Westinghouse Union Battery Co.       | 329 |
|                                       |      |                                    |      |   |      | Weston Electrical Instrument Co.     | 316 |
|                                       |      |                                    |      |   |      | Wholesale Radio Equipment            | 342 |
|                                       |      |                                    |      |   |      | Willard Storage Battery Co.          | 309 |
|                                       |      |                                    |      |   |      | Willart Sales Co.                    | 336 |
|                                       |      |                                    |      |   |      | Wilmington Fibre Specialty Co.       | 306 |
|                                       |      |                                    |      |   |      | Wireless Mfg. Co., The               | 312 |
|                                       |      |                                    |      |   |      | WorkRite Mfg. Co.                    |     |
|                                       |      |                                    |      |   |      | Inside Back Cover                    |     |
|                                       |      |                                    |      |   |      | World Battery Co.                    | 344 |
|                                       |      |                                    |      |   |      |                                      |     |
|                                       |      |                                    |      |   |      | <b>Y</b>                             |     |
|                                       |      |                                    |      |   |      | Y. M. C. A. Radio School             | 308 |
|                                       |      |                                    |      |   |      |                                      |     |
|                                       |      |                                    |      |   |      | <b>Z</b>                             |     |
|                                       |      |                                    |      |   |      | Zin-Nec-Ker Co., The                 | 322 |

# Be a Radio Operator

## Earn Big Money

## See the World

## Without Expense



An Operator on One of Our Ocean Liners

Learn at home to fill a REAL position in the world's fastest growing industry! Hundreds of big pay jobs waiting for trained men. Read what one big newspaper says about this crying demand for radio operators.

### A Great American Newspaper Says This About Radio:

(This article appeared in the San Francisco Call and Post, May 21, 1923.)

#### SHORTAGE OF RADIO MEN THREATENS SHIPPING

By Al. S. Peterson

A shortage of radio operators threatens the world's shipping.

Unless the American boy can be lured from the simplicity of the radio telephony and persuaded to learn practical wireless telegraphy, the operator shortage will soon become so serious that it may be impossible to secure enough men to provide radio needs of shipping, according to C. H. Blake, marine manager for the Federal Telegraph Company. He added:

"The situation is not critical at present, but it will be soon. All of the surplus supply of experienced radio operators has been put to work. We just managed to get enough to supply the demand from the cannery fleet and stations this year.

"It will now be necessary for the wireless companies to secure some sort of co-operation from the shipping men and the public if men are to be trained for the work that is demanded by law for certain classes of ships.

"The situation confronting the world's shipping can only be attributed to the lure of the broadcasting. Those vitally interested are arranging to get together for the purpose of planning some method to meet the situation that threatens.

"We believe there should be some feasible method that can be depended upon to attract young men to take up the study of radio telegraphy, which offers an opportunity for travel, health and splendid compensation."

How often you've dreamed of travel—of being able to talk from experience of the gayness of Paris, the splendor of a Mediterranean sunset, the quaintness of a Chilean village, the poverty of Oriental settlements, the antiquity of Egyptian landmarks—these and a thousand other interesting scenes you've read about or seen in movies.

Now you can see the world—not as a hurried tourist who sees little and feels nothing, but with comfort and quietness, and earning splendid money all the while. You can be equally at home on a London tram or in a Venetian gondola; you can be as familiar with the native characteristics of the Chinese coolie as the Spanish peasant; you can in truth be a real citizen of the world, enjoying experiences rarely granted to men.

#### A Splendid Education The Life of an Officer

You will find that travel affords a splendid education. In your travels about the world you will learn much. You will meet the world's greatest variety of peoples. On board ship you will come into contact with the wealthy traveling public and the prosperous, active business class. In port you will be free to roam around and to explore all the interesting points both in the seaport towns and the surrounding country.

You travel in real style. On board ship you enjoy all the privileges of an officer. Your work is most fascinating. Messages to all corners of the world pass through your fingers. You occupy a position of great responsibility, a position which gives you a fine chance to make valuable connections in case you ever want to give up the sea and settle down.

Radio operators are in big demand on

land as well as sea. In case you want to give up the sea, you have a wonderful opportunity of stepping into a splendid land position—operator at a land station, at a broadcasting station, or any one of hundreds of the more important big paying positions in radio. The splendid training you receive in qualifying as an operator will bring big money to you no matter where you decide to settle.

#### Send for New Booklet

Learn more about this world's fastest growing industry. Send for new illustrated booklet "Your Opportunity in Radio" which describes in detail the glorious opportunities in this field. Radio calls you from land and sea, and offers you more money than you could possibly earn in other fields.

Write now for this interesting booklet which tells you how you can become an operator or qualify for any other of the better positions in radio. It will be sent to you without cost. Mail coupon for it NOW.

### NATIONAL RADIO INSTITUTE

Dept. 13-I WASHINGTON, D. C.

#### NATIONAL RADIO INSTITUTE

Radio Headquarters  
Dept. 13-I, Washington, D. C.

Please send me your FREE catalog "Your Opportunity in Radio" describing your Home Study Course which will qualify me to become a government licensed operator for land or sea position.

Name .....

Address .....

City ..... State.....



## Perfect Performance Guaranteed

**A** Type V, Armstrong Regenerative Receiver — \$20 — Formerly known as  
**ACE** Crosley Model V. For performance  
**E** no receiver at its price can equal it.

An Evansville, Ind. man writes, "The other night I tuned in Kamach, Hawaii and held the concert for one hour. The music was clear and the speaking distinct." This is indeed a tribute to efficiency.

Ace Receivers are licensed under Armstrong U. S. Patent 1,113,149.

All Ace sets are equipped with the Crosley multistat, the universal filament control rheostat, for all makes of tubes.

Wave length range 200 to 600 meters.

Ace Instruments perform all we claim—and more besides.

Live Jobbers and Dealers are eagerly taking advantage of the sales these instruments and the other Precision instruments and parts are bringing them.

*Free catalog on request.*

New York Office, C. B. Cooper, 1803 Tribune Bldg.,  
154 Nassau St. Phone: Beekman 2061

Boston Office, B. H. Smith, 755 Boylston St., Room 316.

Chicago Office, 1311 Steger Bldg., 28 E. Jackson Blvd.,  
R. A. Stamm, Mgr.

Philadelphia Office, J. H. Lyte, 65 North 63rd St.

St. Louis Office, Robert W. Bennett Co., 1326 Syndicate Trust Bldg.

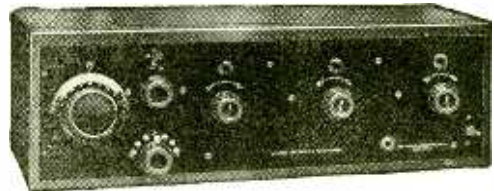

We announce the Ace Type 3B—a new 3 tube Armstrong Regenerative set with filament switch, jack, new Crosley molded sockets and condensers with molded plates. This is one of the latest and most efficient sets on the market today for steady performance.

# THE PRECISION EQUIPMENT COMPANY

POWEL CROSLY, JR., President

922 GILBERT AVENUE

CINCINNATI, O.



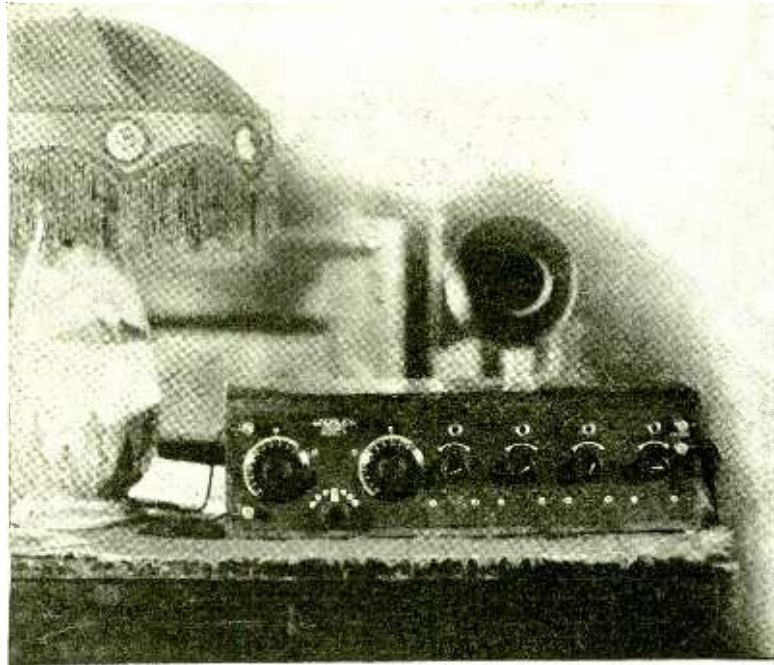

# PERFECT PERFORMANCE

## *Crosley Model X Gives Better Radio Reception*

The popularity of Crosley Model X is becoming more manifest each day.

This four tube set—still priced at \$55—maintains its marvelous record of bringing in distant stations.

A man writing from Chatham, Va., says, "First let me state I own a Crosley Model X and you couldn't buy it for the United States mint. I have picked up over 130 stations in the U. S. and have listened to Havana, Canada, North Dakota, San Francisco, all Texas and ships at sea. Keep up the good work!"

You can depend upon an instrument bearing the name

# CROSLEY

This name has been accepted as a guarantee of the highest quality at the lowest cost.

All Crosley sets are equipped with the Crosley multistat, the universal filament control rheostat for all makes of tubes.

Wave length range 200 to 600 meters.

Other Crosley parts include: Variable Condensers, Knobs and Dials, V-T Sockets, Variometers, Vario Couplers, Rheostats and the well-known Crosley Radio Frequency Amplifying Tuner.

A Crosley Instrument performs everything claimed for it—and more besides.

*For Sale by Best Dealers Everywhere.*

*Write for Free Catalog.*

We announce a new model —to be known as Model X-J. This has all the features of Model X and in addition—new molded sockets, new rheostats, new condensers, with molded plates and jack for head phones.

Price ..... \$65

## Crosley Manufacturing Co.

922 Alfred Street, Cincinnati, Ohio

New York Office, C. B. Cooper, 1803 Tribune Bldg., 154 Nassau St. Phone Beekman 2061  
 Boston Office, B. H. Smith, 755 Boylston St., Room 316  
 Chicago Office, 1311 Steger Bldg., 28 E. Jackson Blvd., R. A. Stemm, Mgr.  
 Philadelphia Office, J. H. Lyte, 65 North 63rd Street  
 St. Louis Office, Robert W. Bennett Co., 1326 S. Vudicate Trust Bldg.

# Good news for the radio fan

## *Announcing a complete line of Exide Radio Batteries for all types of tube sets*

**E**VERY radio fan who has tuned in with an Exide A or B battery will welcome the news that the popular Exide line has been extended to include two low-voltage A batteries. An Exide Radio Battery is now available for all types of vacuum-tube sets.

Whether you want a long-life storage battery for six-volt tubes, an A battery for low-voltage tubes, or a B battery, you can take your choice of Exide Radio Batteries and be sure of getting the right battery for your set.

### *For low-voltage tubes*

The two newcomers in the Exide radio family are two- and four-volt A batteries for tubes consuming .25 amps. at 1.1 to 1.5 volts and those using .06 amps. at 3.0 to 3.5 volts. These sturdy little batteries were specially designed to meet the requirements of WD-11 and UV-199 vacuum tubes. Weighing less than 6 lbs. each, they are midgets in size, but giants in power.

Exide Radio Batteries give steady, dependable current with only occasional recharging. They

make it possible for you to reproduce broadcast selections in clear, bell-like tones. When your set is hooked up with an Exide, you have ample power for maximum signal strength at all times. You can tune in distant stations with the most satisfactory results.

### *In service over a generation*

For more than a generation the famous Exide Storage Battery has helped to turn the wheels of industry. Long before radio broadcasting achieved its present popularity, the Exide proved its worth in commercial and marine wireless; it is used today in a majority of all government and commercial wireless stations. When the American public found in radio a new form of entertainment, the Exide became by reason of superiority the leading radio battery.

You can get an Exide Battery from a nearby radio dealer or Exide Service Station.

Ask the dealer for booklets describing in detail the complete line of Exide Radio Batteries, or write direct to us.



*For six-volt tubes*

Like all Exide Storage Batteries, the Exide A Battery for six-volt tubes is dependable and long-lasting. It is made in four sizes, of 25, 50, 100 and 150 ampere hour capacities.



*Two- and four-volt  
A Batteries*

The new Exide A Batteries consist of one and two cells, respectively, with rated capacities of 12 and 24 ampere hours. The two-volt A Battery will heat the filament for 96 hours; the four-volt A Battery for 200 hours.



*Exide B Batteries*

give noiseless, full-powered service over a long period of discharge. Designed throughout to prevent electrical leakage. Capacity, 3 ampere hours.

# Exide

## RADIO BATTERIES

THE ELECTRIC STORAGE BATTERY COMPANY, PHILADELPHIA  
Service Stations Everywhere Branches in Seventeen Cities



# RADIO NEWS

H. GERNSBACK—Editor and Publisher  
ROBERT E. LACAULT—Associate Editor

EDITORIAL AND GENERAL OFFICES, 53 PARK PLACE, NEW YORK

Vol. 5

SEPTEMBER, 1923

No. 3

## Music vs. Radio

THE whole country has been watching with interest, and we believe with considerable annoyance as well, the fight between the music publishers and authors, conducted against radio broadcasting stations. The controversy in brief is that the music publishers and authors insist that the broadcasting stations pay them a royalty on their musical compositions, and until this payment is forthcoming, they refuse to let the broadcasters use their music. They claim this right under the copyright law.

Technically the musical interests are, of course, right. We believe they have the power of stopping anyone from using their musical compositions if the broadcasters do not pay for the license.

But the stupidity and short-sightedness of these self same musical interests would be ludicrous if it were not so appalling.

These musical interests, when they get out a new piece, will not hesitate to resort to any means in order to bring it to the attention of the public. Thousands of copies of sheet music are sent out free, and common hand-organs are hired to drum the piece into our heads. Vaudeville and motion picture theaters are in some cases paid good money simply for playing the piece in order to popularize it. Many musical compositions as yet unknown are sandwiched in some musical comedy for the simple purpose of getting them before the public.

When it comes to the greatest advertising medium, radio broadcasting, music publishers hold up their hands in horror and say that we are ruining their trade because if everybody listens to a musical composition by radio, none will wish to buy the sheet music, piano rolls or phonograph records. How these facts rhyme together only the music trades can make out. No one else, unbiased, has as yet been able to understand the peculiar slant of mind of the people behind the movement.

The childish arguments that are used by some of the champions of the cause are often amusing; witness the following, which appeared in a recent issue of the *Music Trades*:

"I am opposed to the radio broadcasting of music, especially the popular variety, for the very good reason that the practice is inimical to the welfare of the record and roll trade and, by no means last, the talking machine and player industry. When radio fans in the larger cities can hear solid dance programs played by the foremost orchestras with a \$5 outfit, it is only reasonable that they should ignore their player or talking machine, even if the rolls and records were supplied them gratis. Other forms of free public music are necessarily insignificant when compared with radio broadcasting."

This statement is made by none other than Mr. Arthur A. Friestedt, President of the United States Music Company of Chicago.

Following along the same line of logic, if Mr. Friestedt goes to see a musical comedy and hears a certain piece

that he likes he will promptly forget all about it. Contrary to his argument, however, as he leaves the theater, he will buy a copy of the selection for himself or for his daughter. As a matter of fact that is just what happens. The piece that was broadcast from the theater has pleased him and he wishes to either play it himself or let a member of his family do so.

If proof is wanted we might cite the following:

"A typical example of the effect of radio broadcasting was furnished by the testimony volunteered at the first meeting of the National Association of Broadcasters when Mr. Wendell Hall, a song writer, made the declaration that 'Mellow Moon' which he had written, made no appreciable headway in the hands of a publisher who resorted to the usual avenues open to publishers for exploiting a new musical creation. There was practically no sale. Then Mr. Hall began singing 'Mellow Moon' at KYW and WDAP Broadcasting Stations. He stated that in the month of April the sale of 'Mellow Moon' jumped to 100,000."

We believe that the entire controversy now staged by the musical interests against the broadcasters is nothing but a hoax and is not being conducted in good faith for the following reasons: The musical interests realize that in Radio they have a tremendous advertising force that will popularize a given piece of music more rapidly than any agency ever did. They know that sooner or later the broadcasters will no longer advertise their music free, but in the near future will wish to be paid for the tremendous service they are now rendering music publishers.

Down in their hearts, the musical interests know this and wish to forestall this move by making a demand upon the broadcasters themselves. They figure that if they could secure an agreement for a number of years, a compromise might be reached whereby the broadcasters would continue to advertise their musical productions free. We hope that the broadcasters will see through this game and will not allow themselves to be ensnared into a long time contract to their detriment.

The value of indirect advertising through broadcasting is tremendous. When Grand Opera Houses and Musical Comedies are playing to empty houses, they often resort to broadcasting one or more acts of the production. The result is like magic. The writer has seen it happen time and again when for instance a Musical Comedy was broadcast from Broadway that the attendance rose to tremendous proportions during the next few days. This is not a vague general statement, but has been carefully checked up from actual observation and with talks among theatrical producers. And the time will come, as the writer has predicted before, when theatrical producers will pay broadcasting stations handsomely for broadcasting one or more acts of their productions, and that time is nearer than any of us realize. If broadcasting stations can fill otherwise empty houses they should and will be reimbursed for such services. This is legitimate and we believe fair.

H. GERNSBACK,

# What Secretary Wallace Thinks About Radio

By J. FARRELL

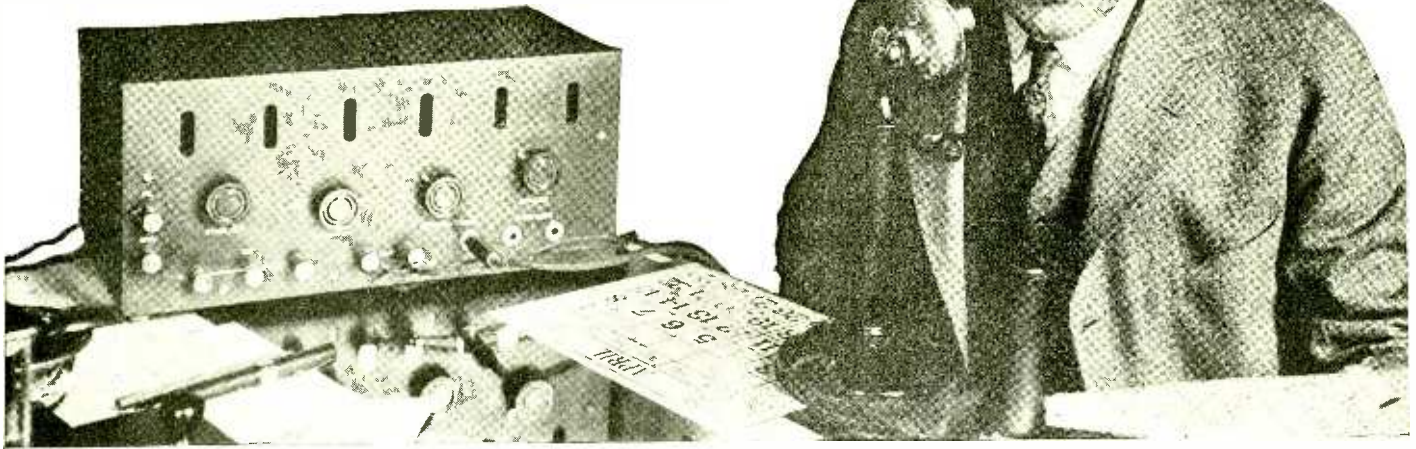

Henry C. Wallace, Secretary of Agriculture, at His Desk. Personally Broadcasting Market Reports by Means of a Special Line Connection With the Transmitting Station. With a Sensitive Receiving Set He Can Keep Tabs on All Reports Sent Out. Under Secretary Wallace's Supervision, the Broadcasting Service, Extended to the Farmers by the Bureau of Agricultural Economics, Has Developed Into a National Service and Has Proven to Be One of the Most Important Steps in the Progress of American Agriculture.

**H**ENRY C. WALLACE, Secretary of Agriculture, is a radio fan. Small wonder! Under his direction he has seen the market news broadcasting service of the Department of Agriculture develop in less than two years from an experiment to a national service that is one of the most important steps of the century in the progress of American agriculture.

Here's what he thinks about radio:

"The amazing development in the transmission of the spoken word by radio and the prompt adaptation of this discovery to the use and needs of the farmer mean much to the future of our agriculture. By the use of the powerful Government sending stations and the 500 and over limited broadcasting stations, it will soon be possible for any farmer, no matter where he lives, to receive daily reports on the receipts and prices of grains, live stock, and farm produce of all kinds. All that will be necessary is to install a receiving instrument."

#### HELPING THE FARMERS

The agricultural economic work of the Department of Agriculture was recently reorganized to bring to the farmer the business facts of agriculture in a practical way. The wide dissemination of the information developed is regarded of vital concern to the farmer, and in this radio is playing a large part. Regarding this phase of the work, Secretary Wallace says:

"The United States Department of Agriculture has taken an active interest in the development and use of the radio, because we recognize it as a medium through which the farmers of the land can be kept posted on what they need to know concerning farm markets.

"These market reports are sent out by the Department through the Bureau of Agricultural Economics, which is a consolidation of the Bureau of Markets, of Crop Estimates and of Farm Management. This new Bureau of Agricultural Economics will give special attention to what we may call the business side of farming. It will study production and

consumption, both at home and abroad. It will study more efficient methods of farm management. It will study the marketing of grains, live stock, vegetables, and all farm crops, and will try to simplify marketing methods with a view to reducing marketing costs, thus helping both the producer and the consumer.

"By the use of radio as well as the telegraph and mail, it will try to keep the farmers of the land posted on prices and marketing conditions."

#### RADIO TELEPHONY RESPONSIBLE FOR SUCCESS OF PLAN

When radio was first suggested as a possible means of getting agricultural news to farmers in remote sections of the country, the idea was laughed at. That was before the perfection of radio for popular use. As one joker wryly put it, the proposition was to fill the air with gossip so that farmers could shove a fish-pole out their bedroom windows each morning and catch a nice fat market report for breakfast.

Due to the vision of Secretary Wallace, farmers are now catching market reports from the air, not with fish-poles, but with the latest types of radio equipment. The ability to do so means money to them, and indirectly, money to the consumer through improvement in marketing methods that the information concerning agricultural conditions is enabling farmers to employ. No longer is radio on the farm a joke, but a vital, practical service; attests none other than Secretary Wallace himself.

The Department's early experiments in radio for broadcasting market reports consisted of sending out from the radio telegraph station of the Bureau of Standards at Washington, a brief market review each day over a radius of about 200 miles. The idea took like wildfire, and amateurs in Maryland, Pennsylvania and Virginia were soon copying down the messages and relaying them to farmers by telephone. The service was then extended to include the broadcasting stations of the Air Mail Service across the country, and the attention of Congress was directed toward the work. Represent-

tatives from farming districts were particularly enthusiastic over the service and gave it the stamp of approval.

When the radio telephone was perfected for general use, the Department's new service rode high on the crest of the radio waves that swept the country. Requests for permission to broadcast the Federal market reports began to pour in on the Department, and several dozen broadcasting stations owned by educational institutions, newspapers, and private broadcasters generally were soon flashing the pews over agricultural regions. In less than two years the number of stations has steadily increased until now more than 90 public and private broadcasting stations are regularly sending out the messages.

#### TIME IS MONEY, RADIO SAVES IT

The market news service of the Department is now receiving more attention than ever before. The practical value of keeping farmers informed of agricultural happenings, of removing the barriers of isolation that inevitably enclosed them by reason of their distance from centers of activity is being appreciated in a big way. Congress recently appropriated additional funds for the extension of the Department's market news service, and it is planned ultimately to cover the entire country with the reports. Serious consideration is being given the discontinuance of the Department's 3,300 miles of leased telegraph wires that connect more than 50 branch offices in consuming centers and growing sections in favor of radio. Tremendous savings in telegraph charges would be effected by the change. It will then be possible as Secretary Wallace says, "for any farmer, no matter where he lives, to receive daily reports on the receipts and prices of grains, live stock, and farm produce of all kinds."

The nation is already fairly well covered with the radio service, but when all the 500 broadcasting stations throughout the country are flashing out the market news, farmers everywhere, in valley or on mountain top, will know as much of what is happening in the national produce markets as do the dealers and speculators located in the markets.

# The Radio Amateur In A New Field

By HERBERT H. FOSTER

**T**HE present popularity of radio and its adaption to so wide a field of utilitarian purposes has caused the practice of the new means of communication to become a component part of some of our finest motion picture productions. Judging from the inclination of authors and scenario writers to employ radio in one way or another in their plots, it appears as though there was a permanent place for the radio amateur on the technical advisory staff of every producing director.

And why not? The retinue of specialists, who act purely in advisory capacities on every production staff, are no mean part of the organization. The well organized motion picture producing company might almost as well be without performers as without its historical adviser, director of art, decorative specialist and a dozen other specialists who make sure that a picture of the fourteenth century, before the invention of the clock, does not get by with a clock in the church tower, or that a Louis XV suite of furniture does not get into a Renaissance setting by mistake. And as important as this, in the present day of motion picture perfection, is the task of the radio amateur adviser who will now see that the prominent star does not start hearing things on a transmitting set or calling for help from that desert isle on a crystal detector.

And all of this is by way of writing about the grand array of radio apparatus that the writer had the pleasure of seeing employed under the direction of a radio amateur who found his way into the new field in the production of a recent film.

This production, which at the time of writing has but recently been completed and will be released soon by the Film Booking Offices of New York, has radio so closely intertwined in its plot that it will undoubtedly find a way into the heart of the radio fan.

As much care was taken in gathering together the radio equipment as there was in the setting of its scenes and the choice of the cast that puts the picture in the all star class.

Dereys Perdue, who plays the fascinating part of Ann Small in a very charming manner, has an unquenched desire to know more about this business and kept our question and answer editor busier than he has been since the early days of the radio boom,

Warner Baxter, As Jack Dunbar, and William H. Turner. As Dinsmore Bevan. Have Been Trying To Perfect a Method of Transmitting Power Via Radio For Months. The Result of Their Experimental Work May Be Guessed From the Expression of Mr. Baxter's Face.

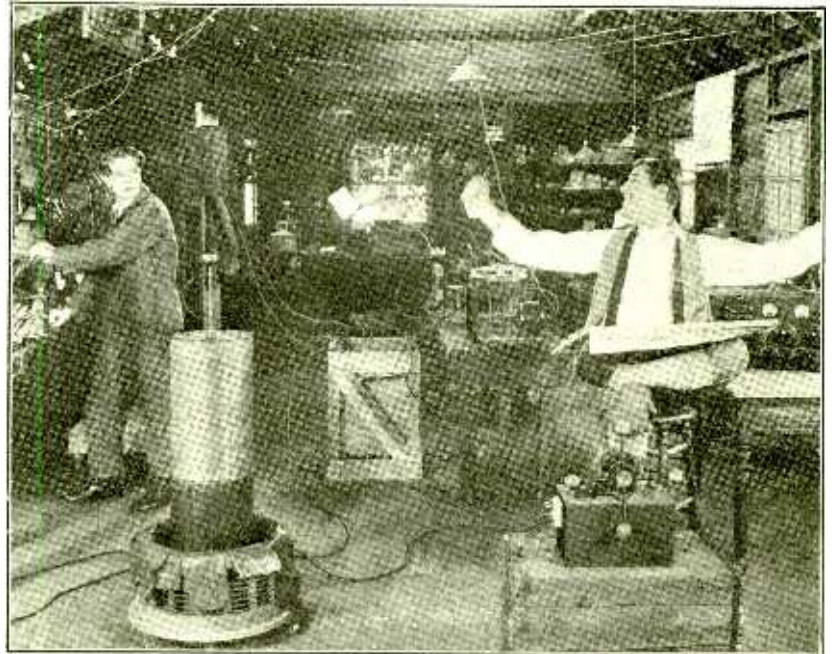

Courtesy of Film Booking Office

when every morning and every night he had to dig his way in and out of the fans' question mail. Miss Perdue is now an undoubted fan and expects soon to pass into the second stage of radio amateurism that just seems, as one of her already bitten fellow players remarked, to "make a fellow have the natural inclination to be forever and ever handing out fifty for this, ten for that and so on to the end of his bankroll."

Warner Baxter, who plays the lead opposite Miss Perdue, in the part of Jack Dunbar, is a fan of long standing. He knows all about the game and has promised the writer that one day he will write an article for RADIO NEWS on the vagaries of the variometer as experienced by an amateur. Mr. Baxter told the writer confidentially that the variometer in the motor of his new car never fails, but that in his radio set it burns out his bulbs several times a week and on this confidential information we have admitted him into fandom.

Space does not permit going into detail regarding the radio apparatus employed in the picture, but several times during the course of production Jimmy Horne, whose real name is James Wesley Horne, and who directed the cast, wished that the whole works was in a place where the wire would melt. There is nothing new in a movie studio. One may take ten steps from the interior of a Fifth Avenue mansion and be in Arabia, Peru or on the Bourse; there are really no geographical limits.

But radio apparatus—that is different. It excited so much curiosity that several times during the day the writer spent there, the studio cop had to shoo away the gathering stars.

The highly sophisticated and the uninitiated found in this a common interest—or, better said, curiosity. The large assortment of radio dodinguses could have well been a varied collection of imported and domestic electrical fly-swatters for all they knew. With open mouths they absorbed the "mystery of it all," which has possessed everyone who has come in contact with radio.

The advent of radio into reel life as well as real life, its present popularity and widespread use and purpose, has added another factor that the author and playwright will have to contend with in their plots unless they do not wish to deviate from the old stock of plots which long before this have become pretty well shopworn from their constant alterations.

Obviously then, radio will play a more important part in motion picture plots. It can and will be employed in many ways, always to an advantage. All of this opens wider the new field for the radio amateur. To be correct in every detail is almost a religion in the motion picture studio and with the more usual employment of radio in motion picture plots the radio amateur will be called in to assure technical correction.

The picture being incomplete and unnamed at the time of this issue going to press, the writer will not enter its theme, but will, in the next issue, when he has seen the completed picture, tell all about its sobs, laughs and thrills, especially the last two, which constitute the major portion of this story that has been adapted for the screen from "Blow Your Own Horn," the very successful play of that name by Owen Davis.

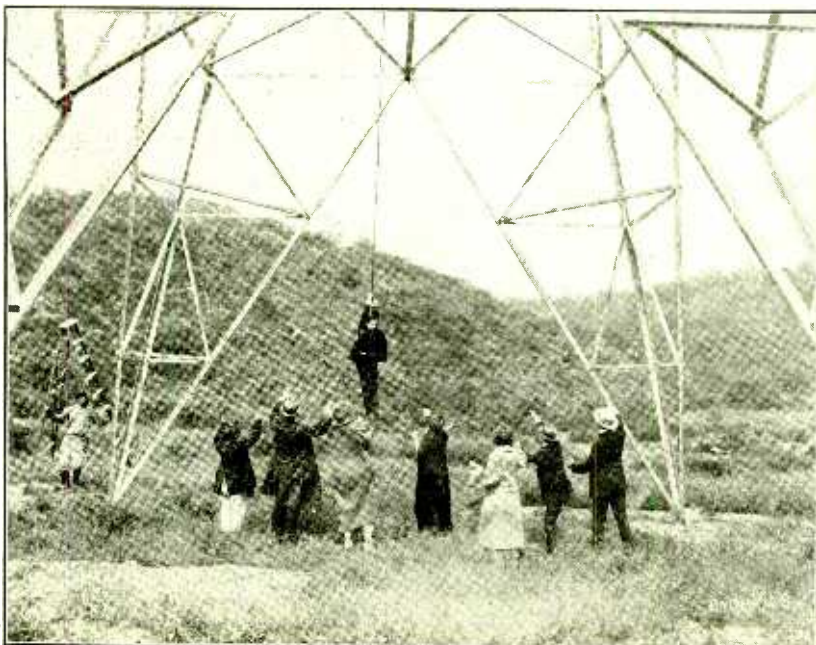

Warner Baxter, As Jack Dunbar, Despite the Protests of His Friends, Starts His Perilous Climb To the Power Line To Open the High Tension Circuit That Is Shorted With the Cabin In Which His Sweetheart, Ann Small (Dereys Perdue), Is In Danger.

Courtesy of Film Booking Office

# The First College Radio Club

By ROBERT F. GOWEN, 2XX

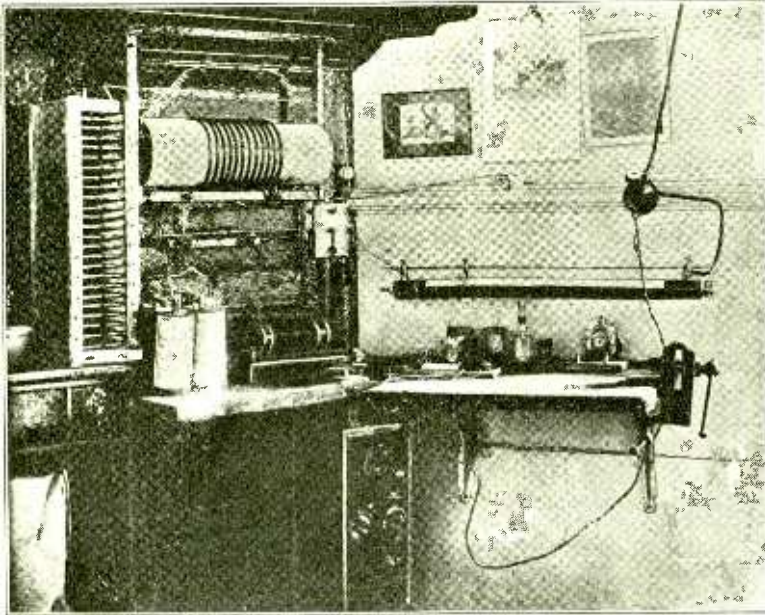

The First Sub-Station of the Weld Phonograph Co., Belonging to N. T. Wellman. Note the Curtain-Rod Tuning Coil.

**B**ACK in the Dark Ages of 1902, long before radio was born, and when wireless was just a pup, a certain young and then very important freshman entered Harvard University, together with a thousand or so others of the same importance. But the freshman in question took with him a small mahogany box containing a remarkable device known then as a "Wireless transmitter." It contained a one-half inch Ruhmkorff spark coil, a glass plate condenser and a spark-gap. This had been constructed with a tremendous amount of effort for the express purpose of making some tests between his home in Ossining, N. Y., and the grammar school, almost half a mile away, which he attended. Strange to relate, the tests were unsuccessful,—not a sound was heard in the receiver. This receiver was composed of a coherer, de-coherer, relay and sounder. Just why the signals from the spark coil did not operate the coherer has never been explained and is still a deep mystery, though recollection bears out the fact that a perfectly good transmitting aerial had been installed, consisting of a copper plate about a foot square fastened to the side of the chimney on the house.

Present day records with spark coils indicate that the trouble must have been in the receiving apparatus and the young "Marconi" we are writing about must have felt that such was the case, as it was not long before the transmitter shown in the photograph was transformed into the receiving set also shown. Several months elapsed, however, during which the wireless transmitter was on display in Quincy Hall, one of the dormitories, and many demonstrations were given, showing how, with the addition of a Tesla coil, the spark coil would operate a Geisler tube and produce many startling and beautiful effects in brush discharge. The outfit, however, was never attached to an aerial, partly because it was impossible to get permission from the owners to put an aerial on Quincy Hall, but mostly because, in those prehistoric days, there were no amateurs in the vicinity with whom to communicate. For this reason, nothing was done wirelessly until two years later when the above mentioned student moved to a room in Weld Hall, one of the dormitories in the College Yard.

The Fessenden electrolytic detector was then coming into vogue. Also rumors of its being possible to hear WCC were abroad.

WCC was the Marconi station at South Wellfleet, Cape Cod, long since abandoned, but at that time it was the largest station in the world. Accordingly the first radio

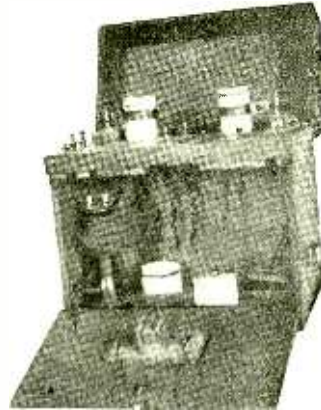

The Electrolytic Detector Set in the Cabinet of the Original Transmitter.

set at Harvard University was transformed from a transmitter into an electrolytic detector set. The illustration shows the two glass-point electrolytic cups made out of cold cream jars on the top shelf with an adjustable dip-point electrolytic detector similarly constructed in the interior. The shelf-like instrument board contained switches to use either of the detectors at will and a switch-controlled potentiometer for adjustment of the detector voltage. The interior contained the dry cells and clips to hold telephone receivers which were of the 75-ohm hand type such as are used on standard desk stands today. A Massey carbon-steel detector will be seen fastened to the inside of the cabinet door to be used in emergencies. The construction of this piece of apparatus caused a great deal of interest on the part of

other students, especially those living in adjoining rooms in Weld Hall, and it was not long before several of these decided that they too would build similar equipment with the hope of eventually copying signals from WCC.

Preliminary experiments with this receiving set, using a bed spring as the only aerial available, caused a sensation when the spark at the Boston Navy Yard was heard faintly in the telephone receiver. This high powered station was at least five miles away! For this reason our inventor had no difficulty in obtaining assistance, and one moonlight night a small group scaled the two cupolas on the top of the building and fastened thereon a fine copper wire which led down to the window of his room. Shortly afterwards, amidst a thrilling stillness this same group listened, two at a time, as there were but two hand telephones, and although it seemed as if they listened for hours in the brief few minutes of the test, not a sound was heard. Our amateur's enthusiasm, however, was not dampened by this failure any more than it had been by the failure of the public school experiments at home. Experiments were immediately started in the design and construction of a tuning coil. This finally took the form of a wooden curtain rod two to three feet long wound with magnet wire and provided with a slider to vary the amount of inductance in series with the aerial. This was necessary in order to tune to the wavelength of WCC, something over 2,000 meters, which was a remarkably long wave in those days. A glance at the illustrations of some of these stations will show rather a distinction from the average amateur station of today and the outstanding feature it will be noted is the curtain rod tuning coil.

Several nights later, after much adjusting, changing and a great deal of research work, a very faint sound was heard in the telephone receiver which was later interpreted as the signals from WCC. There was a surprising amount of "kick" in the poor little weak sound, however, and the efforts put into research work were immediately doubled and trebled with the result that a few nights later the old Marconi spark came in clear enough to copy. But unfortunately there was no one able to copy it and so a telegraph line was speedily installed between the interested group in Weld Hall and almost frantic efforts were made to learn the code. Very gradually it was mastered while apparatus, similar to our hero's, was being constructed by the others, and he, like them, sacrificed



Station "A." The Electrolytic Detector and Tuner are on the Left, the Large Spark-Coil Transmitter on the Right. This was Considered a "Corking" Good Station Back in 1907. It Made Quite Some Splash in the Ether at That.

everything, including studies, to the construction of a deForest type double coupler tuner. Because of fear of the college authorities, no aerials were put up and eventually four receiving sets in Weld Hall were connected to the original aerial. Code practice was frequent and intense, and snatches of WCC's press news were copied from time to time, but it was not until November 21, 1906, that Kenneth S. Johnson, now an engineer of the Western Electric Company, engaged in carrier wave studies, coil apparatus design in radio and other lines, copied the first entirely complete message from WCC. This was quite a record as the press news from Cape Cod in those days was sent at the rate of about 10 words a minute. The message in question contained 245 six-letter words or 1,470 letters. The message was repeated three or four times, beginning at 10 P. M., so that opportunity was given to correct any errors.

By the fall of 1906 the interest and enthusiasm among those in Weld Hall and some others in other dormitories had grown to such an extent that small transmitters were being installed and it was thought advisable by our senior to organize in order to prevent operating difficulties. Consequently the "Weld Phoneptero-graph Company of Harvard University" was formed with the founder as President and General Manager and R. H. Sheldon, his roommate, who was perhaps the most disinterested one in the group, as Consulting Engineer. The Directorate consisted of the charter members, all living in Weld Hall, namely, Q. A. Brackett (now in charge of the manufacture of the Westinghouse receiving equipment at Springfield, Mass.) K. S. Johnson, '07, C. G. Goddard and P. L. Moses, both engineers, and the senior who had started the thing. The striking and artistic title of the organization was supplied by Mr. J. S. Galbraith, a Greek instructor, also living in Weld Hall. When properly translated and diagnosed it means "To write with winged sounds."

The company, which undoubtedly was the first college radio club and is still in existence today under the name of the Harvard Radio Club, boasted of an elaborate letterhead advertising "Wireless messages to all parts of the Yard and vicinity." "Messages Received from Wellfleet, Mass., ships at sea, Boston and vicinity," as well as the cable address of "Wireograph," Boston. The original five stations were known as Stations A, B, C, D and E, that of the President and General Manager being Station A and the others in the order cited above. As other stations came into existence each was assigned a number and were known as sub-stations until transmitters had been installed.

Soon our ambitious senior found it necessary to provide telegraph blanks, and elaborate

rate ones in a pink tone were printed and furnished the station managers. These were known as "Phoneptero-graphs." Using these forms, copies of all messages were forwarded to the General Manager's office for file and bulletins in regard to operating rules, lightning arresters and the use of equipment were furnished the manager by him from time to time. Gradually stations sprang up in the different dormitories and during the winter of 1906-07 six stations were added to the original list of five charter stations. No call letters were assigned to these, the owners using letters of their own choice which would not conflict with others already in existence.

Our hero's post-graduate year 1906-07 opened with 11 stations on the calling list and several others were added during the college year. Station A was moved to 5 Linden Street—a dormitory just off the College Yard, and a large eight-inch spark coil with an electrolytic interrupter operated on the city current was installed to replace the small half-inch spark coil battery-operated transmitter previously used in Weld Hall. It is not recollected as to what wave-lengths were used, but the chances



Station "A" One Year Later, Situated at Cape Cod. This is Quite an Improvement Over the Old One. Note the Size of the Helix and the Stationary Gap Inside the Glass Bulb. At First Glance This Looks Like a 50-Watt Vacuum Tube.

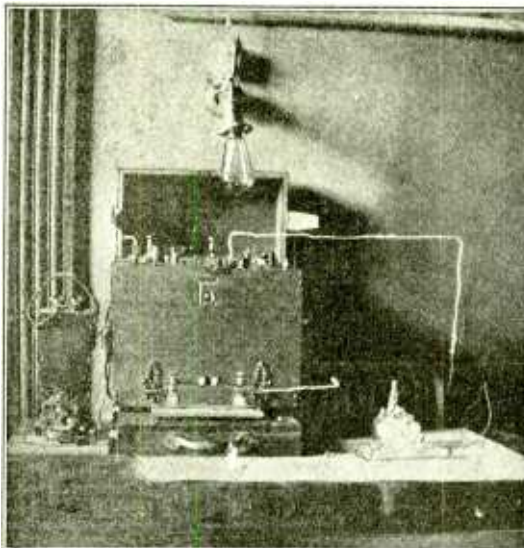

This is the Original Transmitter, owned by Robert F. Gowen, the First Radio Set in Harvard University. It is Rather a Portable Looking Affair, Except for the Stationary Spark Gap in Front.

are they were between 400 and 600 meters, as no attempt was made to use short-leads

with small condensers and the aerials were allowed to oscillate at their fundamental frequency. Interference was, however, negligible, owing to the small number of stations and the comparative inefficiency of both the transmitting and receiving equipment. On January first G. T. Swarts, Jr., Manager of Sub-station 3, got out a blue-printed postcard, containing a calendar and a sketch of Weld Hall. This was sent out as a New Year's card to numerous friends and helped greatly to advertise the activities of the organization. The following year Swarts got out a similar New Year's card.

It was not long before the "Weld Phoneptero-graph Company" was well known and the Boston Sunday Post got out a full page illustrated article under the title of "All the Members of the Winged Words Club, Harvard's Newest Society, Know State Secrets."

Professor G. W. Pierce, noting the interest being taken in wireless at the time, inaugurated a course in wireless. This was known as "Physics 17" and became very popular indeed. Our post-graduate student, then doing research work on the speaking arc lamp in the Jefferson Physical Laboratory and assisting Professor Pierce in researches on carborundum as a rectifier, was very proud to be allowed to assist at times in this course, of which Frederick J. Kolster, until recently a physicist at the Bureau of Standards, was a member.

During 1907-08 the founder of the Weld Phoneptero-graph Company still remained in the confines of the University as Laboratory Assistant to Professor T. Lyman on researches on light of extremely short wave-lengths. For this reason he was able to keep in touch with radio activities in Harvard and to keep alive the original organization until he left Cambridge in the summer of 1908 to join the engineering forces of the American Telephone and Telegraph Company in New York City.

The messages that passed back and forth between the stations fortunately were not censored and many of them contained very choice sentiments in regard to young ladies. The following is a good example:

To C. C. Pope,  
21 Weld Hall,  
Cambridge, Mass.

(Continued on page 296)

ROBT. F. GOWEN, PRES. & GENL. MANAGER  
MAIN OFFICES, 6 LINDEN ST., CAMBRIDGE, MASS.  
Form P. No. 1, 11-07

## Weld Phoneptero-graph Co., of Harvard University

WIRELESS MESSAGES TO ALL PARTS OF THE YARD AND VICINITY

# PHONEPTEROGRAM

| No.                   | Station | Date    | 190                |               |               |  |
|-----------------------|---------|---------|--------------------|---------------|---------------|--|
| Check; Prefix         | Code    | Words   | Station Rec'd from | Time Rec'd    | By whom Rec'd |  |
| Office of origin      |         |         |                    | m.            |               |  |
| Service Instructions: | to      | via     | Messenger          | Time Sent Out | By whom sent  |  |
| O. L.                 | to      | W.P.Co. | to                 | m.            |               |  |

**To:**

We Must Admit That This Message Blank Looks Like Business.. We Can Think of Nothing More That They Could Possibly Have Put On, Except, of Course, a Message. Just How Much Traffic Was Handled in "the Yard and Vicinity" is Rather Vague. The Blanks, However, Were Probably Well Used One Way or Another

# Radio Telephony for Rural Districts

By CAPTAIN H. W. Webbe, Member A. I. E. E.\*

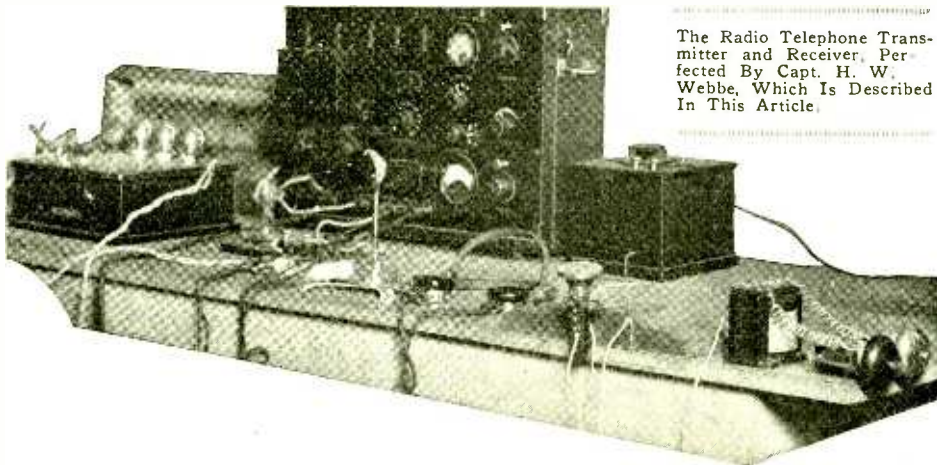

The Radio Telephone Transmitter and Receiver, Perfected By Capt. H. W. Webbe, Which Is Described In This Article.

At the regular annual inspection by the War Department, of the Signal Corps unit of Ohio State University, a demonstration was given to bring out the possibilities of a radio bell. In the principles employed there was a departure from those used in our discussion of radio bells in the July issue; as will be explained later. The demonstration was very successful; the bell rang with the clearness and precision of wired practice. The tuning adjustments were set for a considerable period before the inspection and have remained unchanged since. Loop antennae were used, with SCR 67 field radio phones and two-way telephone conversations were carried on simultaneously, simulating the facilities of a wired circuit. The facility with which this demonstration passed off has prompted the writer to discuss the possibilities of radio telephony for use in rural districts.

The art of radio for years was the plaything of a few. It was the toy of the code artist, the radio amateur. The fascination of it carried him through the many crudities of early development. Coherers, spark sets, crystals, tubes, one by one presented themselves in a long series of development until there was evolved that high efficiency in radio practice which preceded and made possible the introduction of broadcasting. Up to this time the general public took little interest; to them it was Greek and mystery. Then the broadcaster came along and the public began to hear intelligible sounds. Since then, interest has spread to all classes of people and condensers, grid leaks, variometers are topics of general conversation.

## RADIOPHONES IN RURAL DISTRICTS PRACTICAL

The writer sees in this enthusiasm new possibilities, and a new species of radio amateur, the radiophone enthusiast of the rural districts. Radio telephony in the country and mountain districts affords a real field for development as a means of regular communication. It invariably happens in proposing new fields of endeavor that innumerable objections are raised. We will attempt to anticipate and discuss some of these.

The casual observer will say the country districts are too well supplied at present by the large telephone companies with adequate means of communication. Is this a fact? In the Sixth Corps Army Area, with headquarters at Chicago, the Signal Officer made a survey of the telephone situation for his district. Twelve

hundred so-called "chicken-wire" telephone companies were found in operation in the states of Illinois, Wisconsin and Michigan; mostly one or two man concerns. This situation is due to the fact that the large companies cannot economically furnish communications any distance from their regular pole-line routes. A man living five miles from one of these and desiring connection with the regular commercial companies is obliged to pay to the telephone company for line construction the sum of about Eleven Hundred and Twenty-five Dollars; or \$7.50 per pole at 30 poles to the mile.

These "chicken wire" telephone systems are eye-sores to any one familiar with good telephone practice; the wonder is that they work at all. In one case a man, signing himself "General Manager," said he did all his own trouble shooting, as well as looking after the business end of the game. One can imagine, during harvest season, while the general manager is threshing his oats, that if the telephone system blew down, the neighborhood would have to wait until the threshing was over before the system could be put in working order again.

Another objection which one always hears when radio telephony is proposed, as a means of general communication, is that there is no privacy to such a system. As a matter of fact, is there privacy in wired telephony? Have you ever visited a rural telephone exchange when the operators were not busy? A bishop once asked of a little boy, "Who knows everything?" The boy replied, "God and the telephone girl." On long rural lines there is nothing uncommon in having as many as ten to fifteen stations on the line. On the "chicken wire" systems referred to the stations are usually all bridged. In the ultimate development of radio telephony for intercommunication purposes the wave-length would be definitely fixed for each set and tied into a central exchange with communication carried on by remodulation. With such a system it would take a radio engineer to enable you to get off your wave. At the present time even in the cities, if you are curious enough to listen to your neighbor you can take a head set, go out in the backyard, and tap in on his wire.

## WAVE-LENGTHS ARE AVAILABLE

The next question which always comes up is wave-length. It is generally considered that on account of the very broad wave used in modulated C.W., there would be too much interference to make radio telephony practicable. Let us consider; under the new distribution of broadcasting wave-lengths, it has been held that a ten kilocycle difference between waves is sufficient to prevent interference. Now on the wave band below 150 meters it is found that between 50 and 150 meters (6,000 to 2,000 kilocycles) there are 400 wave-lengths having a ten kilocycle difference. Under the new allocation of waves this band below 150 meters has been left open for Army experimentation. There seems to be no reason why these could not also be used for local low powered radio telephone practice in rural districts, without interference from or with the army. And the

(Continued on page 346)

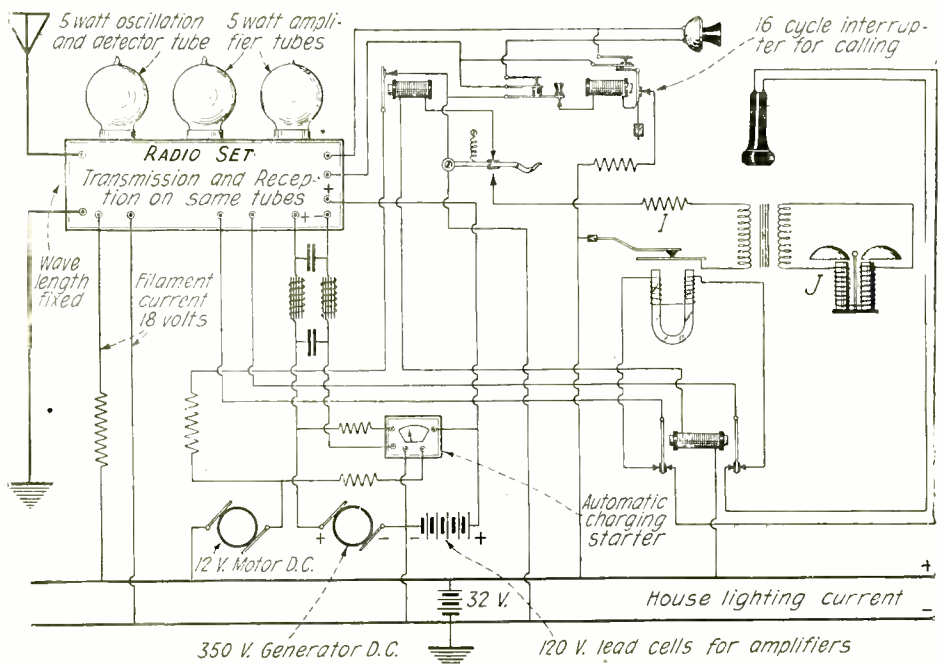

Circuit Adapted For Radio Telephony With Automatic Signaling. These Are the Exact Connections of the Outfit Shown In the Photograph Above. Note That the Same Vacuum Tubes Are Employed For Both Transmission and Reception. The Change-Over Is Accomplished By a System of Relays.

\*Asst. Professor Communications Military Department, Ohio State University.





## Pittsburgh Church Unveils Tablet Given by Unseen Radio Congregation

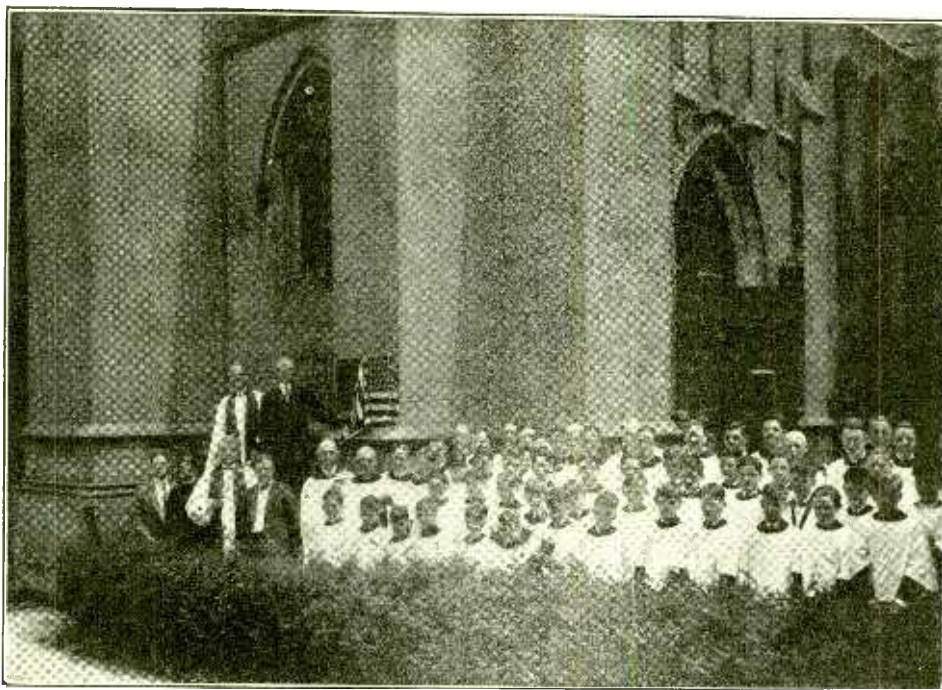

The Boys' Choir of Calvary Church, Pittsburgh, Pa.; Their Voices Travel Into Many a Home by Means of Radio. The Bronze Tablet, Contributed By the Radio Congregation, Is Seen Partially Veiled By the American Flag.

**A** MOST unusual ceremony—the unveiling of a bronze tablet contributed by and dedicated to the unseen radio congregation of Calvary Church, Pittsburgh, Pa., took place during the church services recently.

The Rev. Edwin J. Van Eppen, pastor of the church, who was the first minister in the world to have his services broadcast; Bishop Alexander Mann, of the Pittsburgh Episcopal diocese; H. P. Davis, "father of radio broadcasting" representing Station KDKA, of the Westinghouse Electric & Mfg. Co., which station first broadcast the church services; and other prominent Pittsburghers took part in the ceremony.

More than 4,700 people, representing 40 states of the Union, five provinces of Canada, Cuba and Bermuda, London, England, even sailors from ships sailing the Atlantic Ocean, contributed to the purchase of the tablet. The contributions came in every form of legal tender—silver dimes, stamps, nickels, pennies and checks. There were a surprising number of Canadian dimes. A worker in the Southern Cotton Mill sent Dr. Van Eppen two cotton socks with a nickel in each toe. A sailor from a boat on the Atlantic sent the minister 120 pennies he had won playing penny ante.

These contributions came as a result of Rev. Van Eppen's idea that his radio congre-

gation to which he had been preaching since January 2, 1921, might like to contribute to some sort of memorial. Accordingly, during the reading of his regular church announcements Dr. Van Eppen addressed, directly, his unseen hearers and told them of a plan to have small contributions from such of them as might like to participate. The sum obtained from the contributions was to be used for a memorial dedicated to them.

The first announcement was sent out into the ether one Sunday last February and contributions have been coming into Calvary Church ever since. The amount obtained, all of it in small contributions, has been enough to purchase a beautiful bronze memorial tablet.

The tablet is 30 by 24 inches in size. On it is a relief map of the territory where Calvary's Church has been heard and this includes all of the United States and a considerable surrounding territory in Canada, Mexico and the oceans.

The map is criss-crossed by jagged lines, indicative of radio waves, emanating from the radio station at East Pittsburgh, Pa., where the church services go out into the air.

The entire services, including the dedicatory address, as well as the Calvary Church services, were broadcast by Station KDKA.



The Bronze Tablet, Contributed By and Dedicated To the Unseen Radio Congregation.

## Radio Pays Its Debt to Dr. Alexanderson

**R**ADIO has paid part of the debt which it owes to the genius of E. F. W. Alexanderson, chief engineer of the Radio Corporation of America and a consulting engineer of the General Electric Company.

Monday, April 30, Verner, six year old son of Dr. Alexanderson, was lured from his home by the promise of a gift of rabbits, and kidnaped. The police had practically no clues on which to work; in spite of the active work and close co-operation of newspapers, police and radio broadcasting stations the case appeared to be at a standstill and the whereabouts of the boy remained a mystery for three days.

Bert Jarvis of Theresa, a Jefferson County, N. Y., village of a thousand inhabitants, listening in Monday night on his home-made

radio set heard WGY, the Schenectady radio broadcasting station of the General Electric Company, announce the kidnaping. Jarvis rents boats to fishermen and acts as caretaker for numerous summer cottages in the vicinity of Theresa. A few days before the kidnaping he had rented an isolated cottage to a man who was bringing his family up from the city for the season.

After hearing the radio description of the missing boy and his kidnapper, Jarvis' suspicions were aroused. Tuesday he met the owner of the cottage and asked him who had taken possession. The owner explained that it was only an old woman, a little boy and one man.

It so happened that the man when renting the cottage, had said he was going to bring

his daughter. Jarvis' suspicions grew, and Wednesday he decided to ride out to the vicinity of the cottage in his motorboat. He stopped at the cottage and asked the old woman who came to the door for a drink of water. He entered the house and saw a child on the bed. Jarvis returned to the cottage later and asked for candlewicking for his motor. On this visit he waved to the boy and the boy waved at him.

Thursday morning Jarvis saw a photograph of the kidnaped child in the Syracuse Post Standard and this picture tallied with the boy of the cottage. Now sure of his ground, he reported to the Deputy Sheriff and a few hours later Verner Alexanderson talked over the long distance telephone to

(Continued on page 346)

# An Aspect of the Future of Broadcasting

By JESSE MARSTEN

IT has been ably pointed out by Mr. Carl Dreher that the people interested in radio may be divided into two classes: First, those who embrace radio as an additional medium for the release of energy which has no other channels of escape. These people are imbued with the old amateur instinct and are concerned with the technical details of radio. They rig up antennae, build sets, try out new circuits, etc. The second class is composed of those who are primarily interested in the content of the broadcasting, and are in no way concerned with the technical details involved. Reasoning from this, Mr. Dreher concludes that space radio will always have its appeal for the first class of people, while wired radio, with its attendant simplification of reception, will make its strongest appeal to the second class of people.

## EXPERIMENTERS ARE IN THE MINORITY

Regardless of what particular medium is employed for the transmission of the radio waves, or how it is done, the first class of people will always be able to adjust themselves to prevailing conditions. They have sufficient curiosity and experimental resources to enable them to cope with new conditions or complex systems. These people may, therefore, always be relied upon to take care of themselves. This, however, cannot be said of the second group of people mentioned above. They are interested in the content of the broadcasting. They do not care how it is transmitted, how it is received; they are not interested in the installation of the antenna or the receiver. What they want is the music, the speeches and so on. It is this class of people that is of most importance in any consideration of the broadcasting problem. They outnumber by far the first class of experimenters. Then again, since this second class of people is not experimentally inclined every broadcasting problem must find a solution adapted to this limitation, if such it may be called, of a tremendous radio public.

What particular appeal does radio hold out for most people? As an outlet for pent-up energies which have no other avenues of escape, radio is a boon only to those people who are experimentally and constructively inclined, and this is a very limited group as far as actual numbers go. The novelty attached to radio is relatively short-lived and cannot be a permanent binding tie to radio. When all things are considered there is one feature which is predominant: radio furnishes an additional source of varied recreation and entertainment for Mr. and Mrs. Man along lines of least resistance. The public obtains its entertainment with a minimum expenditure of effort.

## RADIO BRINGS IT HOME

It is an astounding fact that with all our places of entertainment of one sort or another most people are at a loss what to do. Travel in any crowd and the eternal question is, "What will we do tonight?" The difficulty here is not so much that people are altogether tired of existing places of entertainment. There are two factors which primarily produce this situation: first, there is the item of expense; entertainment is quite expensive, especially when we want it a few times a week; second, and we believe more important, people have to make a decision as to where to go, and then they have to go to their entertainers. And it is right

here that radio broadcasting scores its big scoop; it brings the entertainment right into the house. Also while the initial expense of a set may be high relatively, this expense is spread over a very long period. But the important feature is that entertainment is brought right into the house and saves Mr. and Mrs. Man the trouble of deciding where to go and then going.

Yet radio throws another burden instead, on the shoulders of the public. People who never before so much as lifted a hammer or handled a soldering iron are required to rig up antennae and install sets, and repair and maintain them in good condition. For those who are experimentally and mechanically inclined this is all right. But for the great mass of people this is like throwing an obstacle in the way of taking up radio. We hear much of the enormous number of radio sets in use. But the surface is not even scratched. The great mass of people have not yet purchased, and this is not entirely attributable to the infancy of broadcasting. The present purchasers largely belong to

of making up the broadcasting cost. A set sold is a set sold and may not be considered as a source of further revenue even though replacements may sometimes be necessary. There are plenty of concerns to supply these replacements. By renting out sets the company furnishing broadcasting has this continued source of revenue and the ownership of its receiving equipment. The people are paying not only for the use of the set, but also for the broadcasting. To derive the maximum of benefit from such a system receiving equipment must, of course, be built to last. This is largely a matter of engineering development and design and without a doubt can be done.

That is the main point to be considered in relation to radio broadcasting at the present time. New transmitting stations are not required, since they have no relation to the lay public as regards upkeep. Small and simplified receiving units, capable of performing under adverse conditions, are the main requisites. Fool-proof units, closed to the inspection of the users and kept in condition by experts. Radio manufacturers should realize that here is an opportunity.

Such a system means that responsible and well financed companies will have to take the lead. It does not eliminate smaller companies, since there is always that fairly large public that will continue to experiment and build. But it will take care of that still greater lay public which wants radio without too much trouble.

WE present herewith a new thought on RADIO. At least we admit it is new to us, insofar as we have not seen anything published along the same line. Mr. Marsten compares radio to the present telephone, and wonders why people buy radio outfits instead of renting them from maintenance companies the same as they do when they order a telephone installed. Mr. Marsten thinks that if we were to install rented radio apparatus, millions more would be interested than there are now because most of the people are laymen and strongly object to anything that is too technical. The constantly increasing horde of broadcast listeners do not wish to experiment, but just listen in. Is this the solution of the future of RADIO?—EDITOR.

that class of people who are interested technically in one way or another in broadcasting, they are our amateurs and potential amateurs. The real lay public, not interested from a technical point of view, but only interested in the results they can get, namely, entertainment, really remains to be interested. Expecting this public to install antennae and sets and maintain them is almost like asking them to install their own desk telephones and maintain them. It is too much trouble for most people.

## A PRACTICAL SOLUTION

There is one logical solution to this: That is, to furnish installation, maintenance and repair service. This means, to a large extent, that the system in vogue in telephone companies will have to be used. Sets will be rented out by companies, rather than sold, and will be installed and kept in good condition by the renting company. For this a monthly service charge will be made. The user of radio equipment will not have to bother about installing his set or rigging up antennae. If trouble arises he does not have to begin hunting bugs; an expert of the company will be on the job to repair the set, just as the telephone companies repair telephone troubles which arise daily.

Intimately tied up with this is the problem of who is to pay for the broadcasting. The above solution takes care of this problem to a certain extent. At present operating companies hope to pay for the cost of broadcasting by the sales they make. But if a set is once sold the company derives no further profit from this purchaser even though it continue to broadcast indefinitely. It is unlike the talking machine industry in this respect, in that once a talking machine is sold business is still had from the purchaser by the sale of records. The radio broadcasting companies have no such means

## RADIO CONTROL IN GREAT BRITAIN

Recent developments in England indicate that a strong effort will soon be made to relieve the amateur radio operator in that country from having to pay a proposed increase in license and buy his apparatus from the British Broadcasting Company. Radical steps to break the alleged monopoly are predicted, although they may not remove the bar against foreign manufactured radio telephone sets. If development is to be permitted, the whole situation must be simplified, many believe.

The new Postmaster General is said not to be especially sympathetic toward the present arrangement, but it is felt he will insist that apparatus be of United Kingdom manufacture. Many fans in Great Britain want to make their own receiving sets and utilize some manufactured parts. To-day these radio fans can only secure an experimenter's license, but after receiving their permits, they can use any kind of a set or part they desire, and listen-in on all stations. These licenses, it is reported, remove them from the control of the British Broadcasting Company. It is assumed that they are engaged in experimental work, but they undoubtedly listen in on all broadcasting concerts.

The Radio Manufacturers' Association has suggested abandonment of the present method of securing revenue for the Broadcasting Company by license fees and royalties, and collecting the amount necessary for adequate revenue from the license fee. Restrictions against the so-called "pirate" would then be tightened.

According to a statement in Parliament, 35,383 experimental licenses have been issued while as many more applications are on file.

(Continued on page 345)

# Pioneer Work In Ether Waves

By SIR OLIVER LODGE

**E**ARLY pioneering work is too often overlooked and forgotten in the rush of a brilliant new generation, and amid the interest and fresh and surprising developments. I often think, however, that the early stages of any discovery have an interest and fascination of their own, and that teachers would do well to immerse themselves in the atmosphere of those earlier times, in order to realize more clearly the difficulties which had to be overcome, and by what steps the new knowledge had to be dovetailed in with the old. Moreover, for beginners, the nascent stages of a discovery are sometimes more easily assimilated than the finished product. Beginners need not indeed be led through all the controversies which naturally accompany the introduction of anything new; but some familiarity with those controversies and discussions on the part of the teacher is desirable if he is to apprehend the students' probable difficulties. For though he does not himself feel them now, the human race did feel them at its first introduction; and the individual is liable to recapitulate, or repeat quickly, the experience of the race.

A large number now interested in the most modern developments of wireless will have but little idea—perhaps none at all—of the early work, in apparently diverse directions, which preceded and made such developments possible. And even those who are high authorities in wireless telegraphy, and know nearly all that can be known about it, can hardly know the early stages quite as well as those who have lived through the nascent and incubating period. Only those who have survived the puzzled and preliminary stages of a discovery can fully appreciate the contrast with subsequent enlightenment. It may suffice to say that the term "inductance" or "self-induction," which we now use so glibly, did not at first exist; and that so late as 1888 Sir William Preece still spoke

difficult for some of you who are so familiar with these things now to realize the dense state of ignorance in which your scientific ancestors were.

Silvanus Thompson, well known as an historian of science, wrote in 1911 a care-

to overlook the past without regrets.

It may be doubted whether the younger generation, who are so enthusiastically utilizing and perhaps improving the latest inventions, will care much about the past either; but still they may like to know more about the early incipient and pioneering work, on the production and detection of electric waves in the ether of space. With part of this work it is true I was myself concerned, but I must not hesitate on that account, since it was this early work—the outcome of splendid achievement by Kelvin and Maxwell and Fitzgerald and Hertz—which laid the foundations and made all the present superstructure possible.

## ETHER EXISTS

Incidentally, however, I want to say two things to those who are occupied with the subject today. First, do not hesitate to speak and think of the *ether of space* as the continuous reality which connects us all up, and which welds not only us, but all the planets into a coherent system. Do not be misled by any misapprehensions of the theory of relativity into supposing that that theory dispenses with the ether, merely because it succeeds in ignoring it. You can ignore a thing without putting it out of existence: and the leaders in that theory are well aware that for anything like a physical explanation of light or electricity or magnetism or cohesion or gravitation, the ether is indispensable. The ether has all these functions, and many more. I could suggest some which would astonish you! We are utilizing it every day of our lives; and it would be ungrateful, as well as benighted, if we failed to render due homage to its omnipresent reality and highly efficient properties. It lies at the origin of all electrical developments and forms the

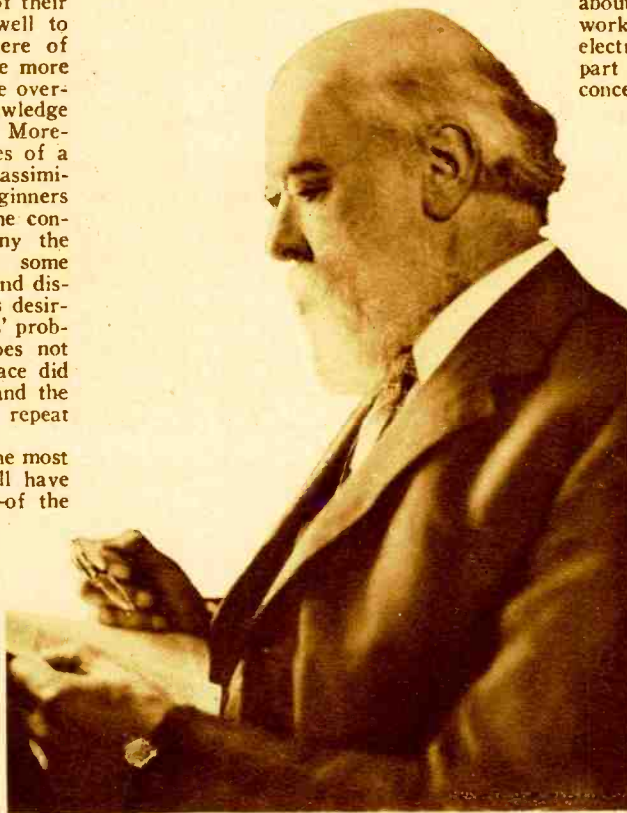

SIR OLIVER LODGE

fully drawn up pamphlet about the history of wireless (though it was never published) for use in a trial before Mr. Justice Parker when my patent for tuned or selective wireless came up for extension. This patent, dated May, 1897, was extended in 1911 for seven years, and was then acquired by the Marconi Company from the Lodge-Muirhead Syndicate. Its validity was subsequently contested before Lord Moulton, but was triumphantly upheld, after twelve days trial, as containing the necessary and fundamental principle of all tuned wireless not involving continuous wave transmission.

But my present subject has nothing to do with details of tuning, nor with wireless in its present condition. That all dates after 1896, most of it after 1900; and I wish to say practically nothing about anything later than 1896. What I have to deal with is the early pioneering work apart from practical developments. And let me here say at once, to avoid misunderstanding, that without the energy, ability and enterprise of Signor Marconi, what is now called wireless would not have been established commercially, would not have covered the earth with its radio stations, and that without the valves of Fleming and Lee de Forest it would not have taken the hold it has upon the public imagination. Before 1896 the public knew nothing of its possibilities. And for some time after 1896, in spite of the eloquence of Sir William Preece and the demonstrations by Marconi, the public thought it mysterious and almost incredible; and still knew nothing about the early stages. Indeed, I hardly suppose that Signor Marconi himself really knew very much about them. He had plenty to do with the present; he felt that the future was in his hands; and he could afford

basis for this new and broadcast method of communication.



JAMES CLERK-MAXWELL

That is one thing. And the second is to congratulate all those whose wonderful and rapid advances have rendered possible the astonishing feat of, in any sense and by whatever means, carrying the human voice across the Atlantic. When Mr. Marconi succeeded in sending the letter "s" by Morse

(Continued on page 349)



JOSEPH HENRY

of it as "a bug-a-boo"; whereas it is the absolute essential to tuning, and even to electric oscillation. Lord Kelvin, who first introduced it as a mathematical coefficient, without any explanation, called it "electrodynamic capacity." The name "self-induction" was given to it by Maxwell, though it was long before it was understood or utilized, and the name "inductance" was a nomenclature of Heaviside. It must be very

# The Radio Gun

By AUBRA R. DUNHAM

**I**T is certainly true that there is no "future" for the criminal. Radio can, and will, be a great crime preventor, as the radio detective is coming into his own.

There are thousands of radio sets in every city, and thousands more are being installed every day. There are several in every city block.

Now, a man carrying a miniature sending station in his pocket, as a flashlight or gun can be carried, would be dangerous prey to

rods of similar length for an antenna, have covered several city blocks with radio waves. All of these instruments, tuned to a certain frequency, or having a peculiar sound, for identification, can be picked up by sensitive radio receivers such as are in the hands of nearly all radio listeners-in.

For example, supposing one of these small sending sets is in your home in some handy place. You awaken in the night and hear someone prowling about the house. Why not capture this prowler instead of entering

device is still silently working and sending out its call for help. When in the vicinity, the radio direction finding compass points directly to the source of the distress call, and the police have arrived on the scene about a minute after the time the first call left your house.

And how will radio prevent crime? These devices can be made very sensitive, and can be hidden around somewhere in an automobile, or in the homes and offices, so that in case any person enters where he does not

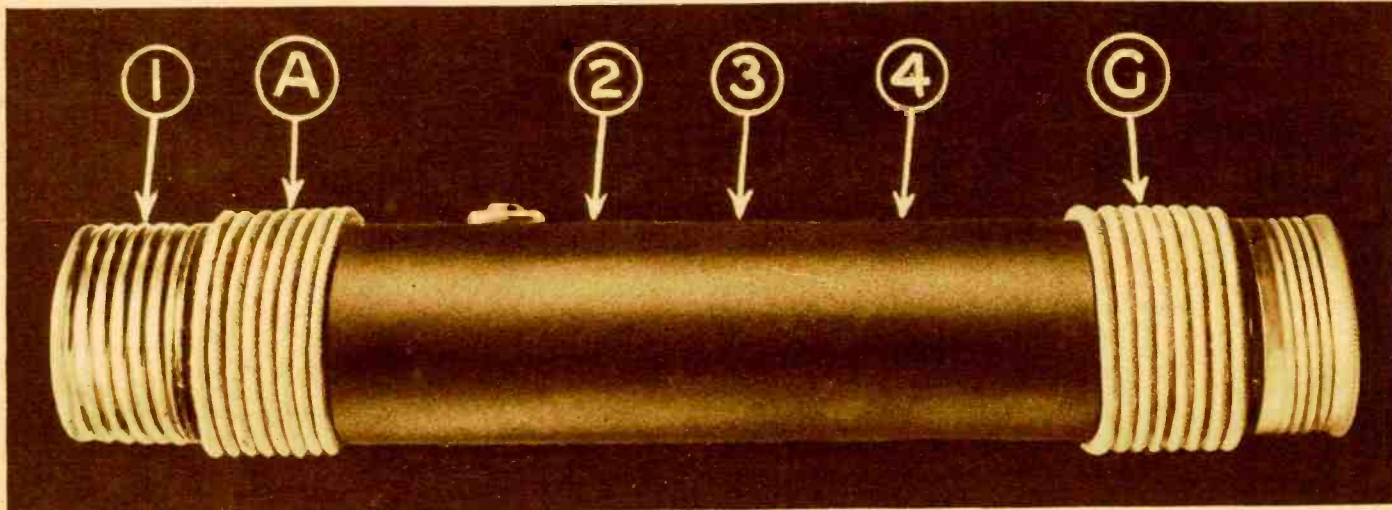

Believing That the Radio Gun Can Be Made a Practical Instrument, We Are Offering the Above As a Suggestion. This, In Its Entirety, Is a Flashlight Case, Having a Small Spark-Coil Transmitter In Its Confines. Instead of Using Two Small Rods, Which Would Be Cumbersome, the Aerial and Ground Are Composed of Two Coils of Wire, "A" and "G." One At Each End of the Case. These Are Connected Directly To the Spark Gap (1). A Transmitter So Arranged Should Be Capable of Reliable Transmission Over Short Distances.

the criminal no matter how dark the night. For all he would have to do in order to obtain assistance would be to press the button on this simple little device which it is now possible to construct. Even his location can be ascertained without any further effort on his part than to press that button. Think what a device of this nature will mean to man for protection of his life and property!

How is all this possible? It is a very simple problem that can be worked out into a perfect system by the radio amateur enthusiasts, and will slowly evolve into perfection, but right now this protective measure can be put to use in a very practical and efficient manner. These miniature sending stations, consisting of only a small size flashlight battery, spark coil and two short

into a possible disastrous combat with firearms in which there is always a danger of shooting the wrong person? You press the button on your little "Protex," which starts sending a silent call to the outside world for assistance. Somewhere in your vicinity an amateur will still be on duty (they always are, no matter the hour, day or night) and will hear your distress call. Or a police car, radio equipped, will respond at once. But if some radio fan does hear your call first, he phones this fact, together with his own location, to police headquarters. The police broadcast this location just phoned in to their radio equipped car or motorcycle officers who are on duty and "tuned in" with headquarters—and in a jiffy they arrive on the scene of the distress call. The little

belong, this instrument is apt to be set off unknowingly to him and he will soon find himself under arrest. A criminal will not dare to trespass in fear of somehow disclosing his own act. A lock switch could be placed on a car, consisting of two buttons, one of which is necessary to start the car properly. If the wrong button is pressed, a silent call will constantly go forth for help, and any police car in the near vicinity will be able to detect and trace down this radio wave being broadcast. Fear rules the criminal, when he becomes afraid to try a thing, because the risk is too great, he will not take the chance of being caught.

With many persons working along this line, a great protective system could soon be

(Continued on page 351)

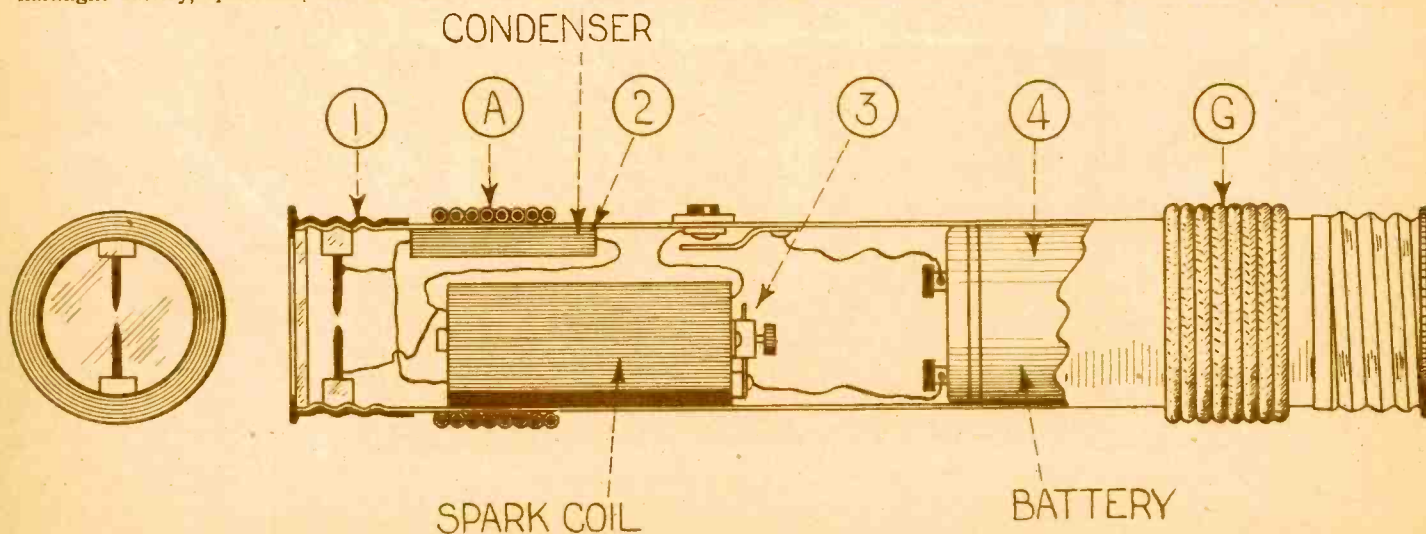

This Illustration Gives a Better Idea As To a Probable Arrangement of the Apparatus. The Spark Coil, of Course, Is a Small One and Is Stripped of Its Covering In Order To Fit the Flashlight Case. The Regular Button On the Case Is Used To Make and Break the Primary Circuit. The Battery Would Not Have To Be of a High Capacity, So Could Be Made of Zinc and Copper Discs Separated By Blotting-Paper Discs Saturated With a Solution of Sulphuric Acid. This Would Supply the Necessary Voltage.

# Radio Pictorial

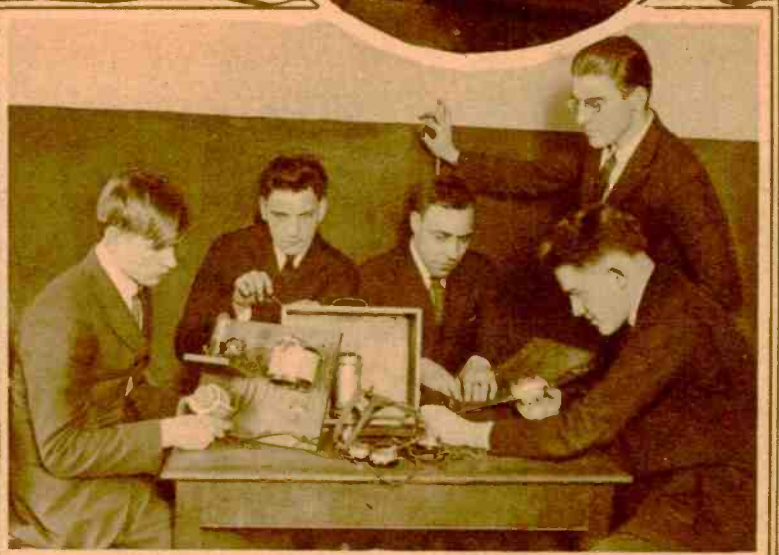
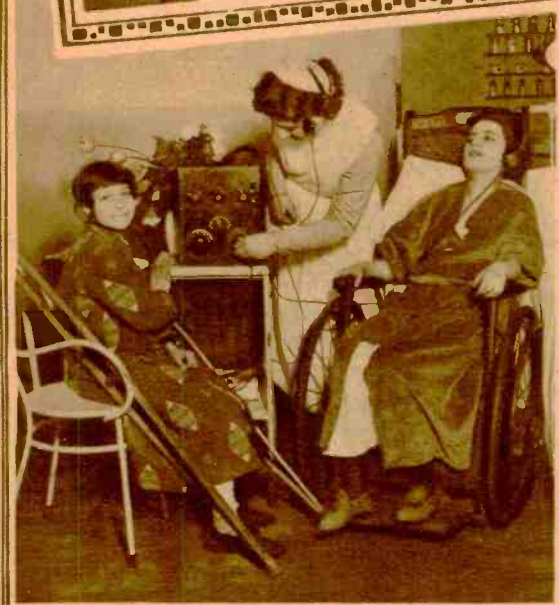
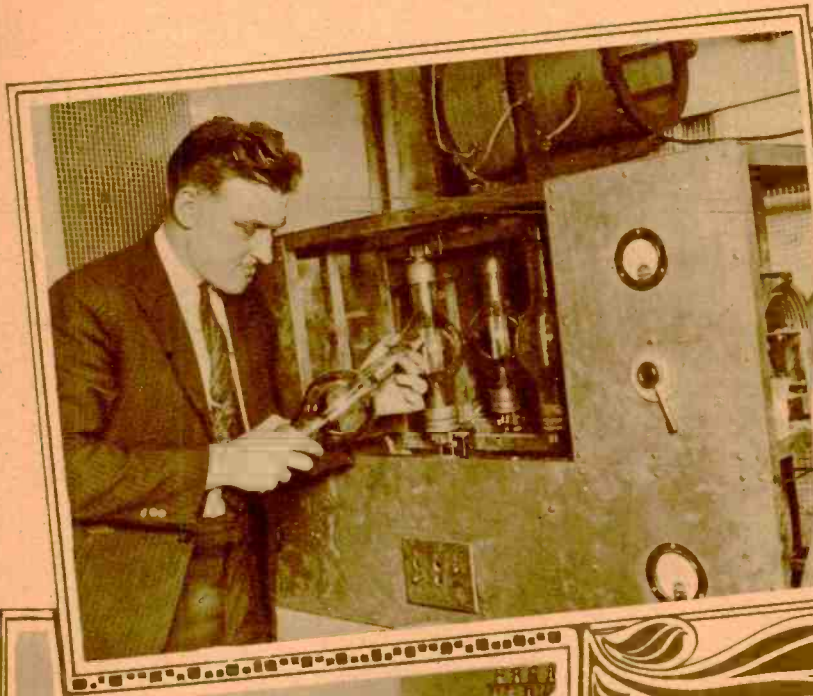

Top: The New Broadcasting Station WDT, Owned By Ship Owners Radio Service. This New Class "B" Station, on a Wave-Length of 405 Meters, Has Covered Great Distances. Charles Burch is Shown Standing Near the 500-Watt Transmitter. To the Right is Shown Miss Vaughn de Leath, Known To Radio Fans As "The Original Radio Girl." She is Now the Announcer and Manager of Station WDT. © K. & H.

Above: The Latest Hospital To Equip the Rooms of Its Patients With Radio is the Beth Israel Hospital, New York. Each of the Rooms Will Eventually Have a Circuit Whereby the Patient, With the Aid of Headphones, Can Listen In To the Broadcasting. © K. & H.

Above: These Boys of the New York Institute for the Blind, All Totally Blind, Made This Single-Circuit Regenerative Receiver All By Themselves. They Are After "DX" Work, Too, and It is Interesting To Hear Them Talk of the Long-Distance Stations They Pick Up. © K. & H.

Left: Photo Shows Secretary of State Charles Evans Hughes Making His Address In Plea For World's Court, At the Kent Centennial At Columbia University. His Address Was Broadcast By Radio Station WEA. On the Extreme Left is Courtist Finch, While On the Extreme Right is the Columbia University Glee Club. Two Thousand Members of the French Bar Were Present. © K. & H.

# Radio Review

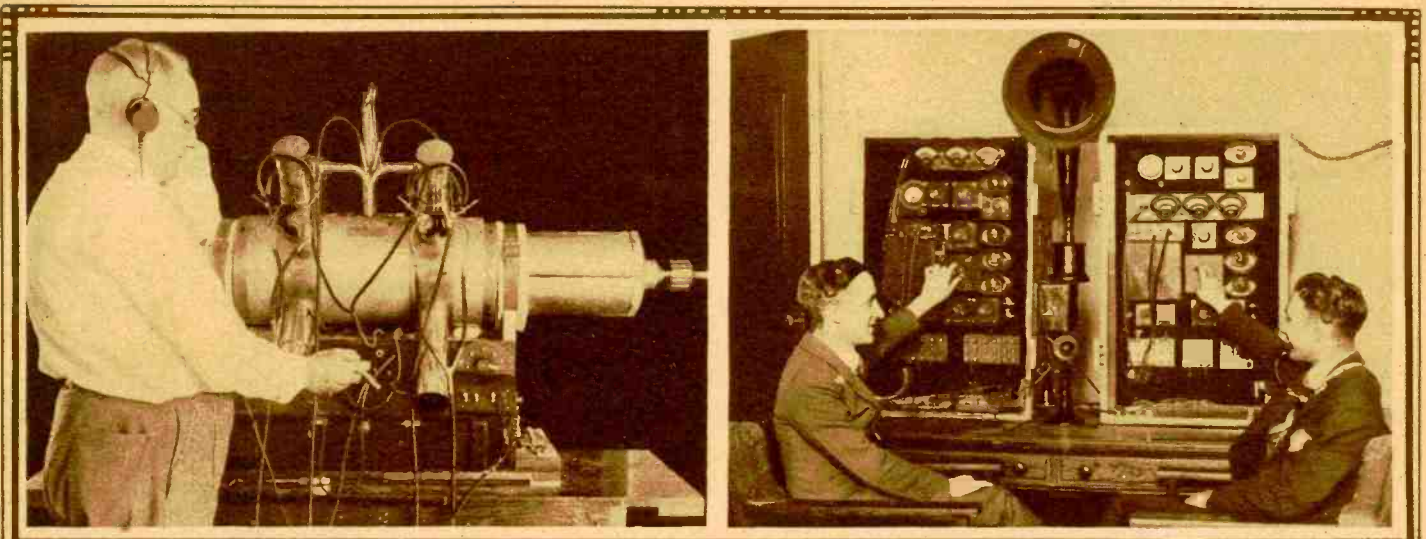

Above, Left: W. J. Scott, the Inventor, and His "Claraphone," a New Device For the Elimination of Static. © P. & A. Photos  
 Left: Chief Operator F. W. Boettcher, At Station "WHN," Checking Up the Wave-Length of the 200-Watt Transmitter. © K. & H.

Right: Miss Anna Case, Metropolitan Opera Star, Recently Sang For An Audience of Probably 5,000,000 People. Her Voice Was Transmitted Simultaneously From Four Broadcasting Stations, Namely, WEA, KDKA, KYW and WGY. The Photograph Above Shows the Two Special Sets of Speech Amplifiers Which Were Used For This Occasion, Each One Operating Two Stations. © Photonews.



## General Harbord Explains The Patent Situation

**A** REMARKABLE feature of the development of radio in this country has been the free manner in which the amateur has been able to use patented inventions, and the enormous amount of effort and money that has been spent in making this possible, and in making it possible for the amateur to obtain the most modern and up-to-date devices, such, for example, as vacuum tubes.

The changes which have taken place in radio during the last ten years are so considerable, and the number of new and patentable devices and "hook-ups" which are used in the average amateur station are so great, that it will be obvious without argument that the average amateur must be using a number of patentable inventions which are so recent that there is every reason to assume that the patents are still alive.

The object of the patent law is to encourage invention; it has been found by experi-

ence that the best way to encourage invention is to give the inventor, for a limited term of years, the exclusive right to that which he has invented. Thereafter, the public gets the invention for nothing. The enormous technical and economic progress of this country is, to a much greater extent than is usually recognized, a result of the fair and liberal character of the American patent system, which, in spite of all the criticism which has been directed against it, is undoubtedly the best in the world.

That system gives the inventor who produces a new patentable invention, as we have said, the exclusive right to make, the exclusive right to use and the exclusive right to sell the new thing which he has invented—not the positive right to make, use or sell, but merely the right to prevent others from doing each of these things.

When a man patentably improves a funda-

mental patented invention, he also is entitled to a patent; he is entitled to the right to keep others, including the original broad inventor, from using his particular improvement. At the same time, the original broad patentee has the right to prevent the improver from utilizing the broad invention. Here an impasse is necessarily created.

### PATENT SITUATION DURING THE WAR

When the European War closed, with the signing of the Armistice, the patent situation in the United States with reference to radio was hopelessly involved. For example, the fundamental Fleming patent, which covered the vacuum tube, was owned by the American Marconi Company, while the deForest improvement patent, usually known as the "Grid" patent, was owned by the American Telephone & Telegraph Company, and other

(Continued on page 335)

# Commercial Radio Installations

## NAVAL RADIO SERVICE INCREASES EFFICIENCY

THE Naval Communication Service in the past three months has made gigantic strides in the efficiency of its service, chiefly through educating its untrained personnel. Courses of radio instruction, in addition to the regular schools at Great Lakes, Norfolk and San Francisco, have been prepared and the results are "very gratifying," a recent report states. Today the personnel of the Communication Service of the Navy is in better shape than in any

Right: The Receiving Apparatus Aboard the S. S. Leviathan. By the Use of Amplifiers These Sets Have a Consistent Range of 4,000 Miles Or More. © K. & H.

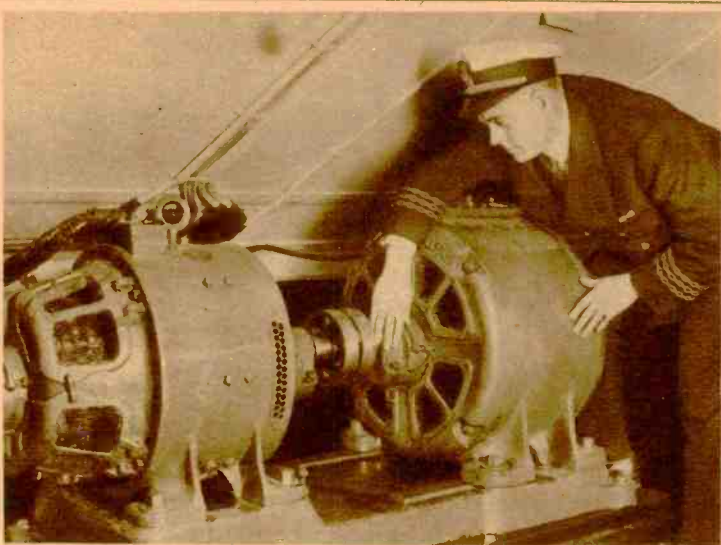
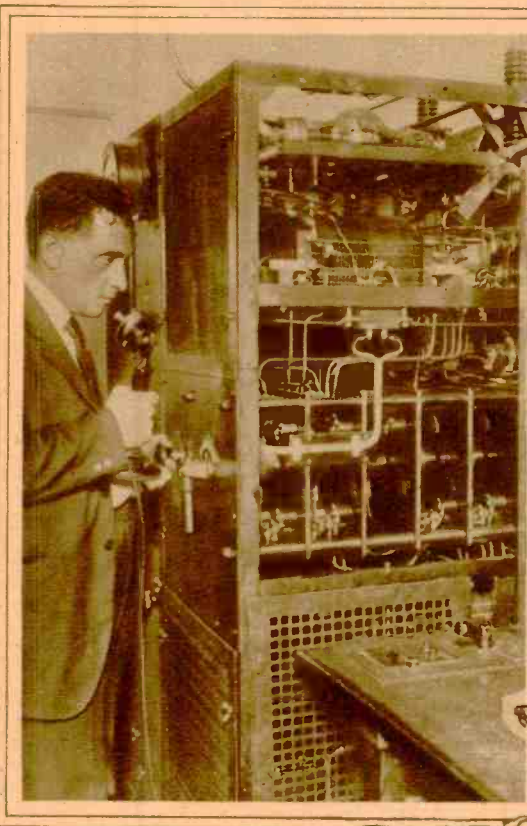
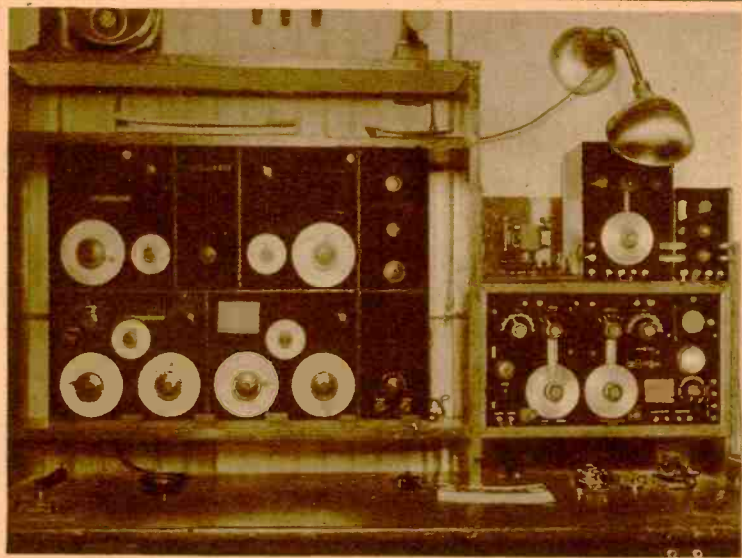

Above: The 10-K.W. Motor-Generator, a Part of the S. S. Leviathan's Powerful Transmitting Apparatus. © K. & H. Below: The Air Mail Radio Station of the Post Office Department of Garden City, L. I., With Manager E. M. Monahan Operating. This Station Keeps In Touch With the Mail Aeroplanes and the Principal Postal Stations Throughout the Country. © Fotograms.

Above: The Powerful Phone, C.W. and I.C.W. Radio Transmitter of the S. S. Leviathan. On Telegraph This Set Has a Range of 4,000 Miles. Duplex Operation Is Employed, Which Insures the Rapid Dispatch of Traffic. © K. & H.

other branch of the service, officers of the Communications Service state.

A survey of the radio personnel situation just completed by the Navy shows that there are 2,443 radio men on duty, and that vacancies in the three higher rates exist. Following examinations held in May, 170 radio men were promoted to higher rates, 15 of them becoming Chief Radiomen.

Opportunities in the Naval Radio Service are good for young men, communication experts point out, citing a recent case where a young man of 20, who held the rate of First Class Radioman, was persuaded to remain in the service, because at 32 he would be eligible for transfer to the Reserve with a regular income of \$75 to \$80 a month.

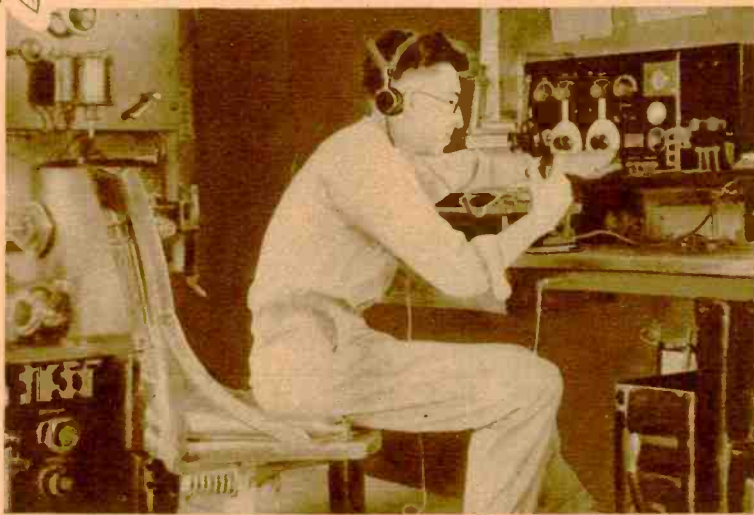

# Summertime Radio

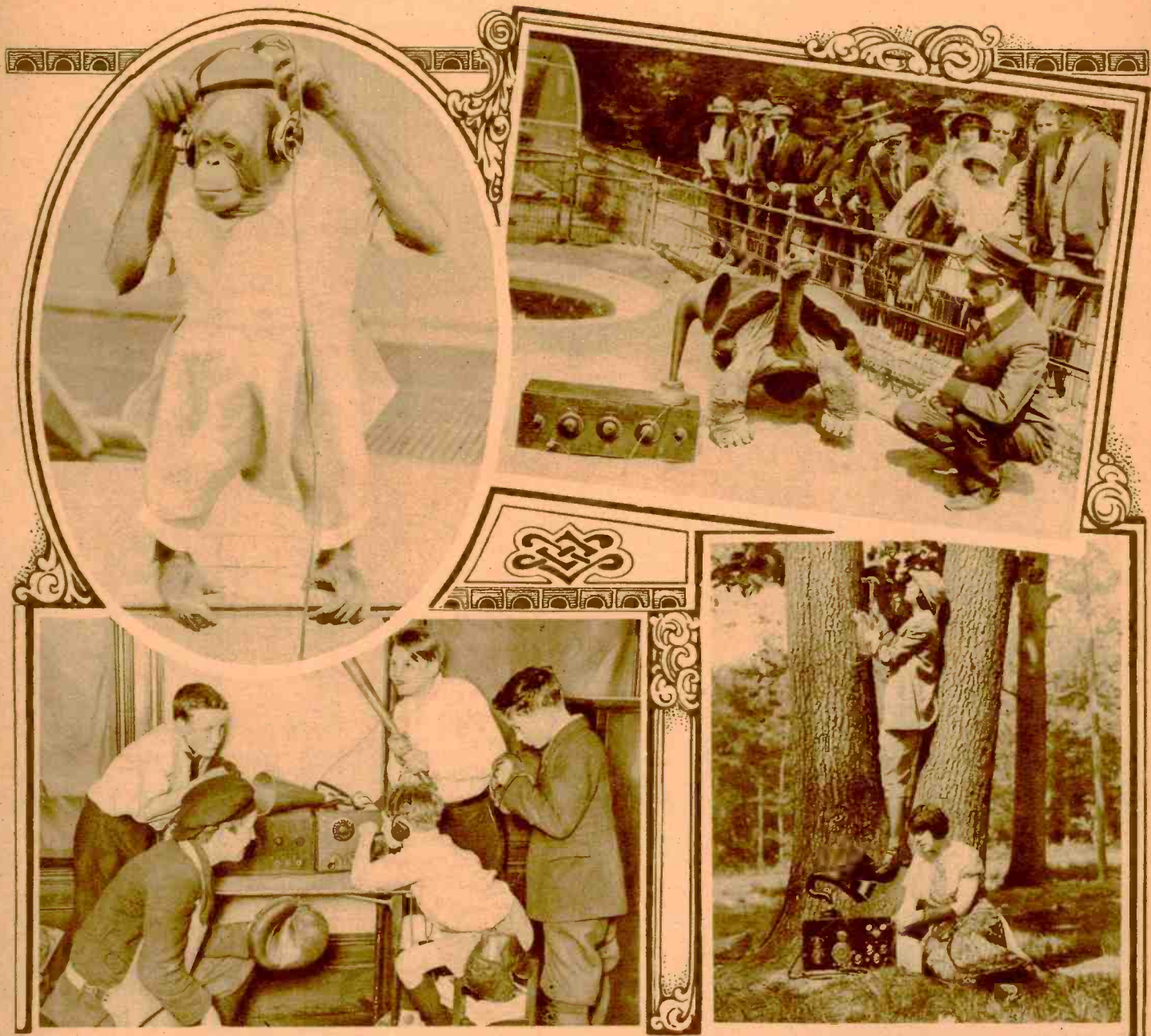

At a recent exhibition at the Bronx Zoological Park, New York, there was installed a complete radio set. The music from a broadcasting station was tried on wild and tame animals, to study the effect it had on these beasts. Grandpa Turtle, who is 700 years old, seems well pleased. The orang-utan, we think, is listening to a bedtime story. He looks sleepy. © K. & H. These boys have founded a baseball radio club to get the returns of the big league games every day. Judging from appearances, they not only listen to the game, but play it as well. © K. & H.



Above: Seventy-five per cent of the vacationists either travel with their cars or have their luggage sent to the country, taking their radio sets with them. The photo shows Miss Betty Nevins climbing a tree to erect an antenna in the garden of her home in the mountains. Soon the music will be pouring through the little horn. Left: As a motor caravan this is the best ever. With a sensitive receiving set this party enjoyed concerts from far off stations while camping on a highway in the Adirondacks. © K. & H.



# Foreign Radio Broadcasting

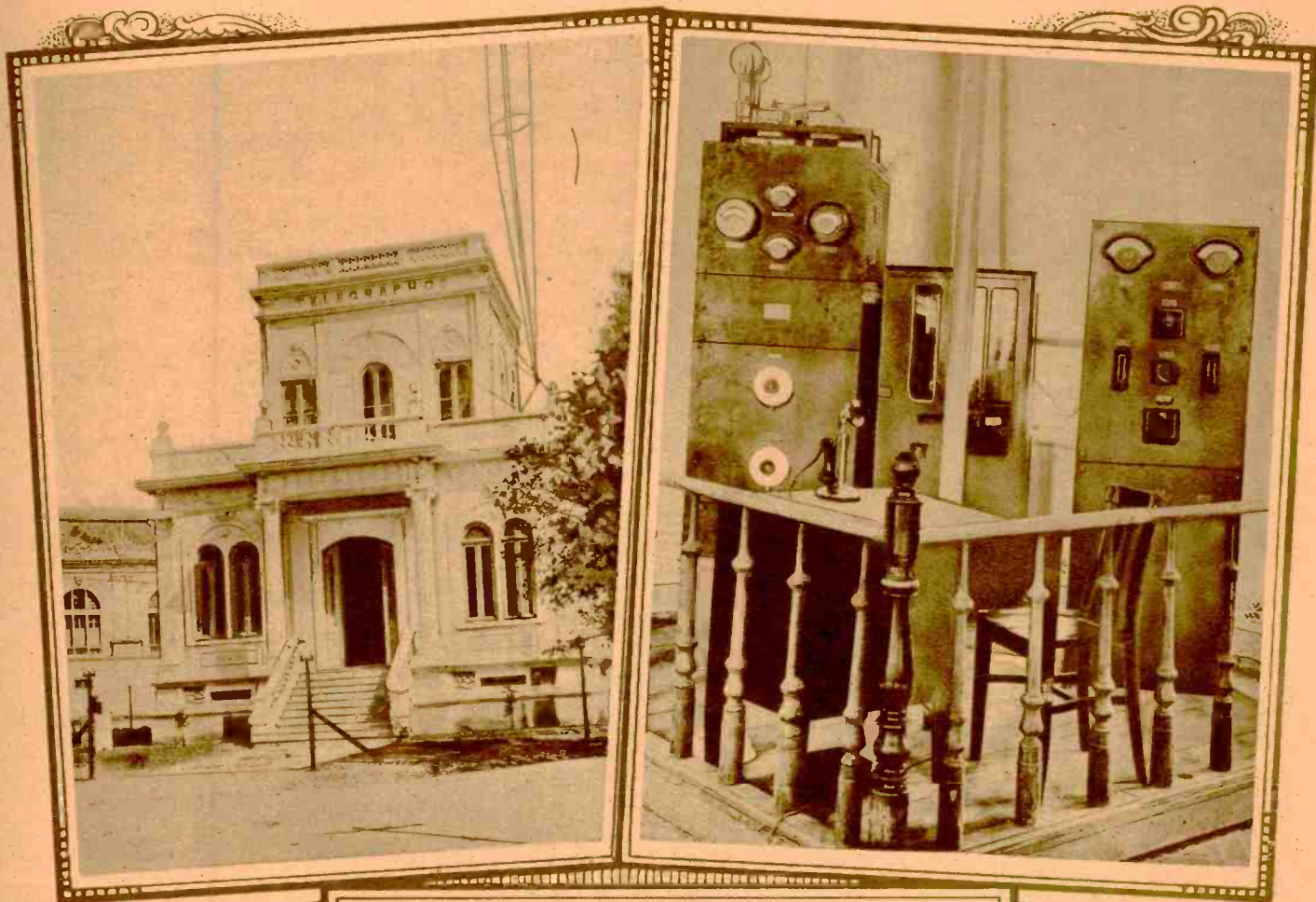

Above is shown the building erected by the Brazilian Exposition to house the Radio Exhibits At Praia Vermelha, Near Rio de Janeiro. The Antenna System of this Station is composed of a Six-Wire-

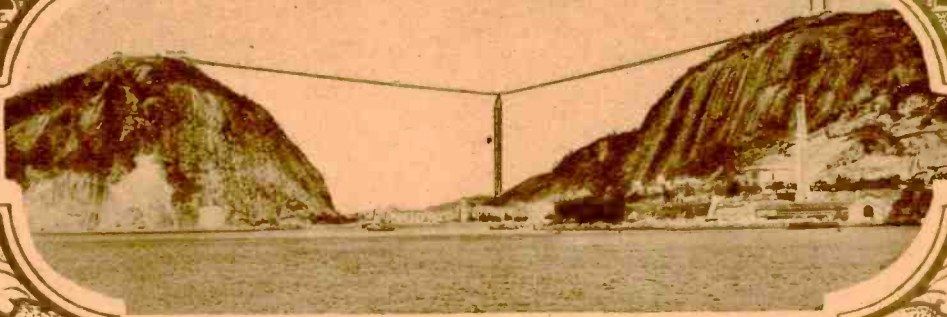

Cage, 500' Long. It is Suspended From a Cable Strung Between the Two Mountains, Vica and Babalonia. Above is shown the 500-Watt Transmitter and Power Panel Used in This New Radio Station.

## Broadcasting And The Swedish Telegraph Department

By Our Berlin Correspondent

**T**HE Swedish Telegraph Department, after duly considering the problem of radio broadcasting, has given out the following statement of its present standpoint:

The Department fully acknowledges the immense importance of the part which radio broadcasting, in spite of its present shortcomings, is called upon to play. The possibility afforded by its agency of carrying immediately to the homes from the outside world a varied program of amusement and instruction will greatly contribute to what might be termed a "renaissance" of home life. No more effectual means of spreading enlightenment in the form of lectures on subjects of general usefulness could be imagined than radio broadcasting. However, while a proper utilization of these possibilities will

create a lasting interest with all the advantages resulting therefrom, an inefficient or clumsy operation of the broadcasting service is bound to bring discredit on the art. A point should accordingly be made of commencing broadcasting activities with a carefully selected program and of maintaining the standard of this program. The Swedish State, therefore, will see to it that only those warranting this excellence of service will be admitted to broadcasting. Instead of allowing full freedom in the erection of transmitting stations, the formation of a Swedish Central company is recommended, in which the radio industry and newspaper press of the country are to be mainly represented. The Press telegraph office will warrant an impartial and objective choice of news and will avoid a competition between radio under-

takings and the press wherever possible.

As regards receiving sets, these are also to be controlled by the State, the Radio Broadcasting Company being invested with a 5- to 10-year monopoly of the ownership and utilization of such apparatus which are to bear the Telegraph Department's check-mark. The sending stations erected and owned by the State will be leased out to the Radio Company. According to calculations by the Telegraph Department, 10 sending stations, each with an antenna energy of 1 K.W., will be required, which will be located at Malmö, Gothenburg, Kalmar, Oerebro, Stockholm, Falun, Sundvall, Oestersund, Umeå and Luleå respectively. The stations of Stockholm, Gothenburg, Malmö and Oerebro are to be erected in the first

(Continued on page 338)

# Radio Novelties

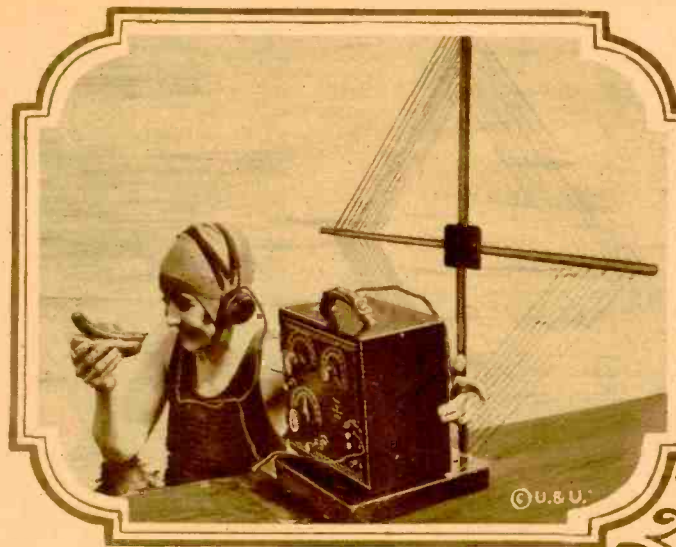

What Could Be Sweeter Than Resting In the Water With a Radio Set and a "Hot Dog" For Companions? Miss Lucy Fox, the Well Known Motion-Picture Actress, Is Having a Good Time, the Radio Supplying Her With Jazz Music. Note That the "Hot Dog" Is Sitting Up and Taking Notice. © U. & U. Above: This Model Ship Is Complete In Every Detail. There Is Installed Inside a

Radio Receiving Set That Really Works. The Girls Shown In the Photo Are Listening To a Nearby Broadcasting Station. Left: A New Feature In Radio Is the Radio Equipped Motorcycle Side-Car. By Means of This the New York Police Can Keep In Touch With Headquarters While On Duty. This Should Prove Very Effective In Running Down Criminals. © K. & H.

## A Radio Live Wire

**W**E had occasion to mention Mr. O. H. Hovey, who terms himself a "live wire and getting hotter," in one of our former issues.

Mr. Hovey, who is only 70 years young, is indeed one of the live wires in radio, and his younger brethren may well be proud of him.

Recently he issued a circular letter, which is so good that we are reprinting it word for word. No radio manufacturer can afford not to read it.—EDITOR.

Our stenographer is so blamed busy "touching up" her already pretty lips and powdering her nose, that we'll just put this letter through the press to save time. But remember it is just as personal and important, and worthy of your attention, as if the aforesaid little bunch of sweetness had written it.

You no doubt received my former circular letter of some weeks ago, in which I gave you some pointers regarding the introducing and pushing of reliable radio goods. (Knowledge of conditions as they actually exist in the field should be of considerable value to those "higher up" in the game). I told you then that the present way—through catalog, salesman, dealer—while it got business, got but a small per cent of what should be realized as a result of expense incurred. I believe it more than ever. On a trip of "nosing around" over this state I find these conditions: Every town, of every size, has a radio "dealer." In too many cases some smart alec has had some stationery printed showing himself as a "radio dealer." On the strength of these headings he secures inside price, from manufacturers of sets or parts. He buys a set for himself, or parts to make one, and that's



all. Too much of this. Then there's the "dealer" who really means well, and actually puts in a set or two, and some parts. He may be a plumber, a druggist or a barber; but all he knows of radio is what he has read in books or catalogs. Not one out of ten of these fellows can tune the set to get proper results; and as for "salesmanship"—0000! Result: Prospective customer "guesses he won't buy yet." Another prospect remarks: "It sounds pretty good here, but I'd like to hear it in my own home." Does that "dealer" get a move on and take a set to that prospect's home and "show him" and make a sale? Not by a dam's height! That "dealer" is no salesman. He has no pep. He is too blind to see real opportunity. He goes home, puts the clock outdoors, winds up the cat, and goes to bed!

After seeing what was going on, I tried out MY way. I took a set and drove into the country. Stopped at first "likely" looking farm house and asked farmer if he had ever listened to radio. He answered, "Yes, a fellow who runs a plumbing shop in town is agent for radio. I went in to hear it one day, but the darned thing rattled and buzzed so I couldn't tell whether it was cussing or singing; so I don't take much stock in the darned things. I read in the papers

though, that there's lots of them being used, and that people seem to like them." Now after hearing that, what did I do? Why I threw a wire over a tree limb, drove a peg into the ground, hooked up the set and tuned in. "Does this sound like what you heard?" I asked. As he listened he yelled "Maria, for God's sake come and bring the kids; you never heard anything like this!" And after they had listened for a while by the roadside I suggested that he let me put the set in his house, and that he invite his neighbors in to spend the evening. He promptly phoned to them, and after a big, real, farm supper, such as most of you fellows who read this know nothing about, the neighbors came, and until after midnight they listened to the wonderful music, lectures and other things that came from far-away stations.

The result? The next morning I had to leave without the set. Farmer just wouldn't let it go. So when I left I had in me two big meals, such as no hotel could supply, and in my pocket a good nice check. Next day tried it again, and it worked again. And it will work every day. Right now there are several good prospects in that little farm community. That's the way to handle radio RIGHT. I next planned to do it BIG. I ordered built a specially constructed body on a light truck chassis, fitted for the carrying of complete sets, as well as a good stock of the "fixin's" to sell to those who build their own. I shall be equipped so that no matter where I light I can be giving a demonstration fifteen minutes after I shut off my motor. The builders promised to rush it, and I suppose they are doing so, but it isn't finished yet; for my plans were for something that would make the public "stand up and look"—as well as listen, and you can't build those

(Continued on page 341)

# Radio Exhibition In Tokio

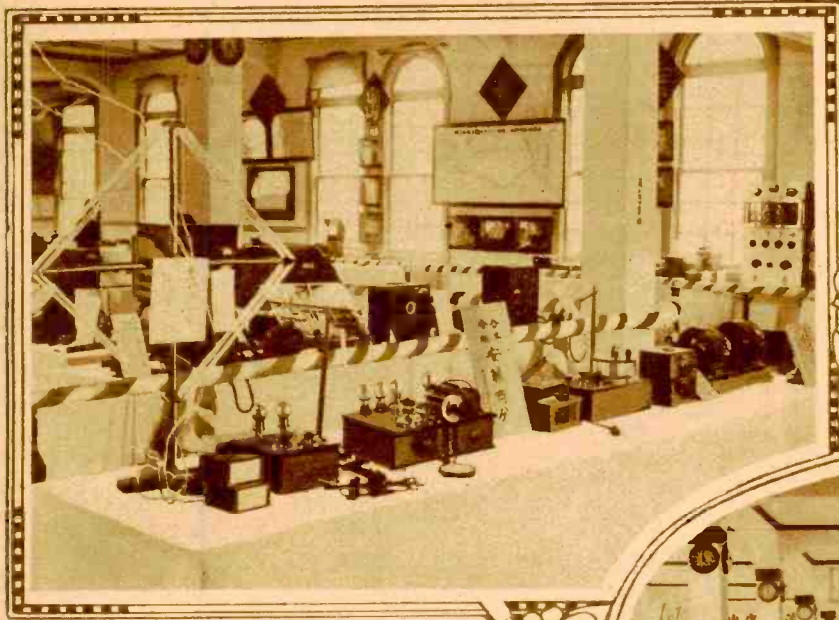

Left: A Section of the Recent Radio Exhibition Held In Tokio, Japan. This Includes Apparatus of French and German Manufacture, Among Which Are a Number of Radio and Audio Frequency Amplifier Units. These Run Far From Our Line of Design. Their Practice Is Usually To Place the Vacuum Tubes On the Outside of the Cabinets. Note the Large Loop Aerial At the Left of the Photo.

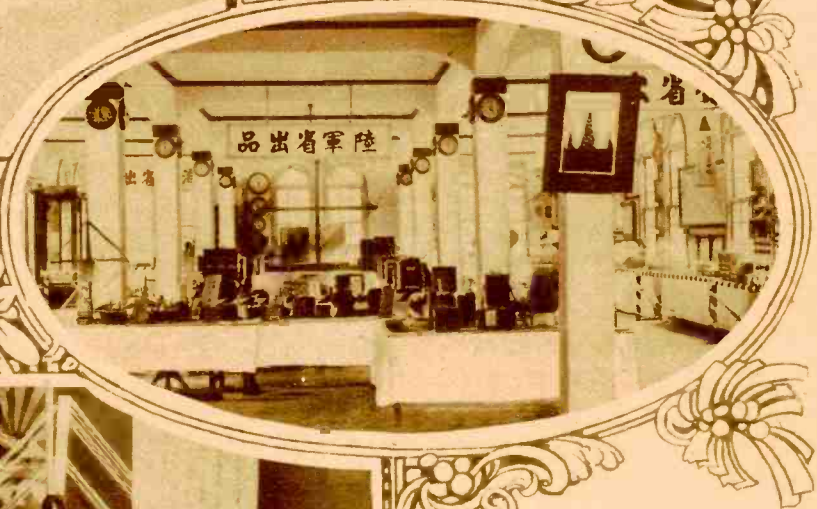

Above: A General View of the Large Room Given Over To the Exhibition. This Is Evidence That Radio Has Taken a Foot-hold In Japan, As It Has In Most of the Foreign Countries. Speaking of a Quantity of Time-Pieces, Notice the Multitude of Clocks Hanging From the Pillars of the Room.



Right: A Booth Given Over To Apparatus of American manufacture. There Are a Number of Westinghouse Receiving Sets Visible, Including the R. C. and the Aeriola Sr. The Large Loud-Speaker Is, Evidently, a Magnavox With the Operating Mechanism Mounted Within a Box. There Will Be a Large Field In Japan For the Sale of Radio Apparatus. Wise Will Be the American Manufacturer Who Takes Advantage of This Opportunity.

THE first exhibition of radio telegraphy and telephony was held at the Industrial Institute of Tokio municipality for ten days commencing April 15. The exhibition was opened to the public on April 16, after due ceremony before a distinguished gathering. President Inouye delivered the opening address and then congratulatory messages were read by Governor Usami, of Tokio Prefecture, and Mr. Hayazaki, Assistant Director of the Industrial Institute. A brief report concerning the exhibition was given by Mr. Kajima, General Manager. All of these messages were transmitted through loud-speakers to the main assembly room, where 500 guests were present, by means of a wire from an adjoining room. Among the participants in the exhibition, there were the Department of Communications, Army and Navy, Tokio Electric Bureau, Waseda University and 52 other representative concerns, both public and private. There were, altogether, more than 2,000 exhibits.

including radio apparatus of both foreign and domestic makes.

Among the principal features of the exhibit were the simultaneous sending and receiving radiophone set and static avoiding device, with a loop antenna and portable V. T. radio set, power tubes of various designs, loud-speakers from the Tokio Electric Tramway and Light Bureau, airplane transmitters and receivers from the Military Aviation School, and vacuum tubes from the Tokio Electric Company, which is closely connected with the General Electric Company of the United States. Quite a number of instruments of American manufacture were exhibited, including Magnavox loud-speakers Westinghouse receiving sets and Radio Corporation vacuum tubes. Substantial proceeds were obtained from the exhibition on the sale of apparatus. From 3,500 to 4,000 visitors attended each day.

Through the efforts of the Kokumin and Hochi, two leading daily newspapers in Tokio, April 12 was observed as "Radio

Day." In the evening of the same day a meeting was held at Hibiya Park, at which lectures on radio were given, followed by a motion-picture show, which drew an enthusiastic crowd of more than 30,000 people. The band from Toyama Military School rendered Madame Butterfly and other selections. Engineer Sayogi, of the Department of Communications, gave an instructive lecture on The Science of Radio Telegraphy and Telephony, which was followed by interesting motion-picture films, illustrating the theoretical side of the science as well as practical operations in the big wireless stations of the world. These films were collected by Mr. Hajima during his recent trip abroad.

The entire exhibition proved to be a great success in every respect, as it aroused the keen interest of the public in radio and its practical operations. As a result of the exhibition, preparations were made for the broadcasting of music and lectures by radio, this being effective in Japan in July.

# Recent Radio Exhibitions

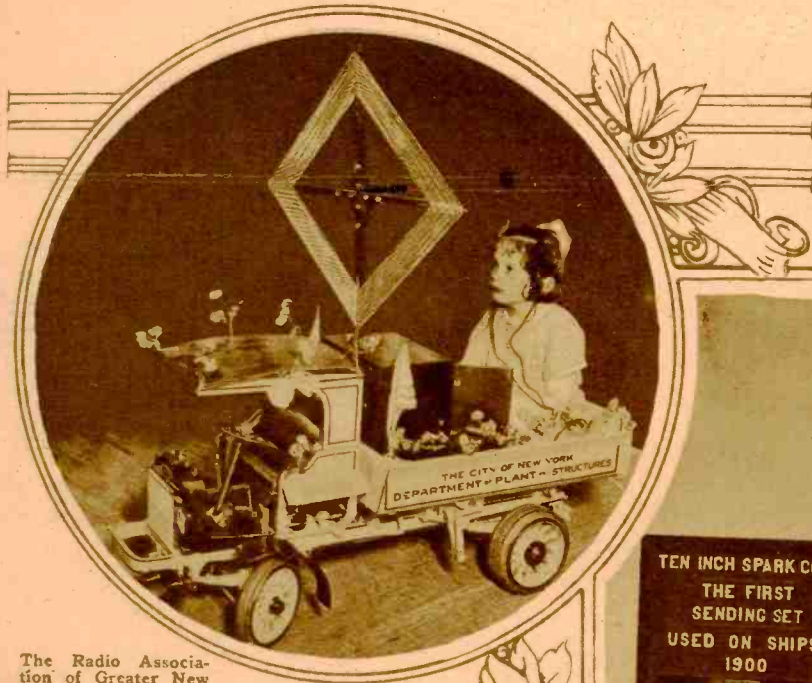

Left: Perhaps One of the Most Interesting Exhibits At the New York City Jubilee Celebration at Grand Central Palace Was This Model of One of the City's Auto-Trucks, Which, Equipped With a Radio Receiving Set, Was Run All Around the Floor of the Palace With Little Miss Mary Whalen, Daughter of Commissioner Grover Whalen, Seated In the Truck and "Listening In" To the Radio Concerts. © K. & H. Below: Raymond Anderson, Chief-Operator of New York City's Broadcasting Station, Playing With the First Sending Set Which Was Used On Ships In 1900. © K. & H.

The Radio Association of Greater New York Is Building Its Own Aerial Tower, Which Will Be 100' High When Completed. © Photonews

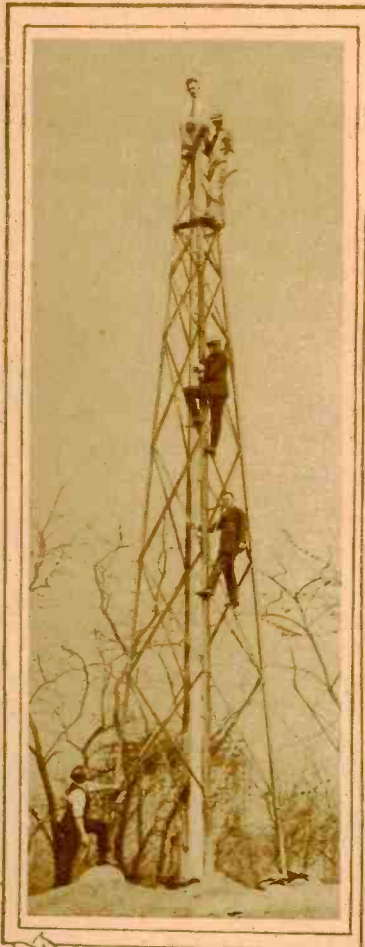

A Competition Was Recently Instituted By the B. & H. Supply Co., Inc., 116 Mathewson St., Providence, R. I., For Amateur Builders. Over 250 Sets Were Entered. Every Set Shown In the Photograph Is Home-Made. Prizes Were Given For the Best Workmanship and Performance.



# Naval, Commercial and Amateur Radio

Right: One of the Best Known Stations In Brooklyn Is That of Edward C. Tassi, Who Is Here Shown In His Station 2CWO. He Uses a 50-Watt Transmitter Employing the Hartley Circuit and Has Been Heard In the Canal Zone, Kansas and Dublin, Texas. He Works On a Wave-Length of 130 Meters. He Works On a Wave-Length of 130 Meters. The Receiver Is of the Short-Wave Regenerative Type, With Two-Step Amplifier and Loud-Speaker. All of the Apparatus In This Station Is Home-Made. © Photonews.

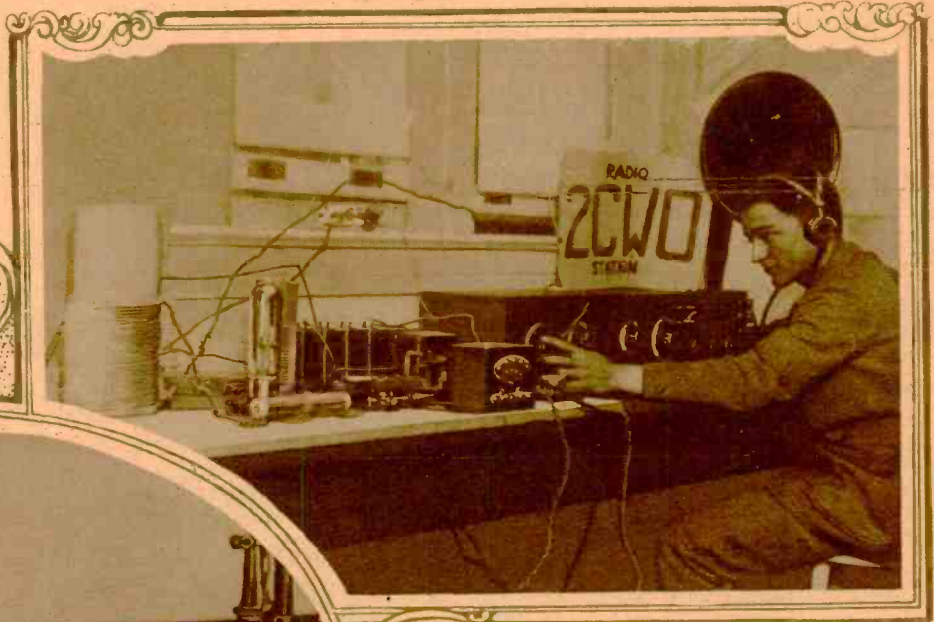

Left: Captain D. C. Hanrahan, U. S. N., Commander of the Scout Cruiser Omaha. In His "Remote Control Station," Which Is Part of the Up-To-the-Minute Radio Equipment of the New Speedster. © U. & U.



Right: Mr. Chandler Goldthwaite, the Brilliant Young American Organist, Leaving On the "President Adams" For Europe. Before Leaving On His Concert Tour, Mr. Goldthwaite Played Several Sunday Night Radio Organ Recitals, Which Were Broadcast From the Studio of the Skinner Organ Company, 677 Fifth Avenue, New York City, Through Station WEA-F.

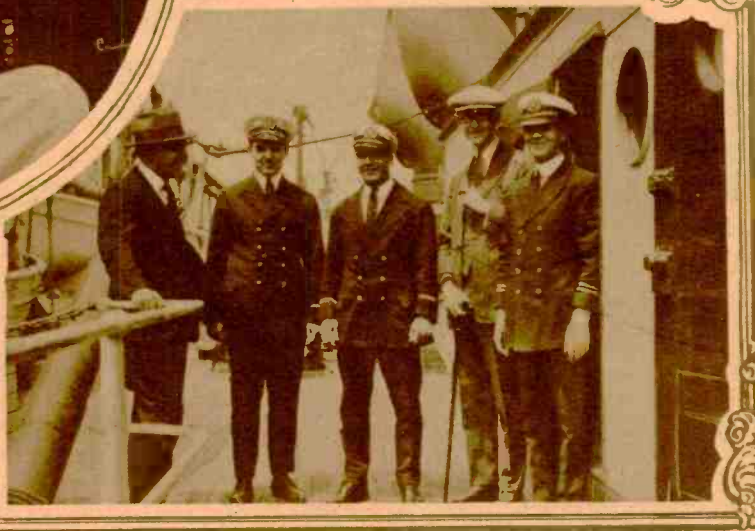

## Radio Public Impatient With Advertising Talks

WE have recently received a great number of letters from readers who seem to be very much disturbed as to the amount of advertising that is being broadcast from our broadcasting stations lately.

RADIO NEWS has always taken the stand that advertising by radio was wrong and that no good can come from it. We print below a letter received from Mr. J. Strickland King, mainly because he has injected a new thought into the controversy. This, while amusing, shows how many people feel about these veiled advertising bills. The other letter republished herewith, was originally printed by *Printer's Ink Weekly* of New York City and reveals our own views on the subject.

Editor, RADIO NEWS:

The amount of advertising that has been

broadcast from the various stations is increasing.

I have put in a small radio for my recreation and amusement and I must confess I am having a lot of fun with it, but I don't propose to be filled with a lot of advertising and sales talk during my recreation hours—and I think it is a very big imposition for big firms to expect it.

Last week I sent a copy of the House Organ put out by the Vacuum Oil Co. to the editor of the *New York Globe*, with a protest. The Vacuum Oil intended to broadcast a talk on Correct Lubrication from 10 stations throughout the country.

I am an advertising man but, nevertheless, I think this is a big imposition.

I talked it over with my President, the publisher of *National Petroleum News* and

he agreed with me, and suggested that I write to you suggesting that you carry some sort of publicity in your paper to try and find out from your readers what they think about this continual use, or increased use, of the radio for advertising purposes.

His idea was rather novel—he suggested that I send in a bill for "professional services" to the Vacuum Oil, telling them that at a certain time they took up so many minutes of my time which was worth so much, and that I must request them to pay me for my time listening to their talk—that the time I took occupied so much of my spare time outside of my business and it was my own time and I could, therefore, sell it.

True, I could tune out this particular station and listen to another one.

(Continued on page 338)

# The McNoodle Brothers' Radio Mystery

By ELLIS PARKER BUTLER

Author of "Pigs Is Pigs"



There Ain't No Sense Into It Whatever. Eagles and Hawks and Airplanes and the Weather-Vanes and Aerial Air Wires Belong Into the Air and Should Be There, and Not Into Under-Ground Trenches In Cellars. Into the Beneath Part of the Earth the Things That Belong Are Bottoms of Fence Posts, Water Pipes, Potatoes and—Lawless Hooch! Yes, Orone McNoodle, Lawless Hooch!

**T**HIS is one of those tense, swift-moving detective stories that makes the hair stand on end; it is the kind of detective story that a man picks up carelessly and then can't put down until he has read the final word, because he can't eat or sleep until he knows how the mystery is solved. And I think it is the first genuine radio mystery story ever written.

The two McNoodle brothers lived alone in a house in our village of West-cote, Long Island, and next door to them lived a mysterious sort of man who went by the name of Philo Gubb. He was a tall, thin man, with the face and gait of a flamingo, and he pretended to be a paper-hanger, but he was really a detective, having taken the complete correspondence course in detecting from the Rising Sun Correspondence School. His housekeeper was an old woman named Betsy Phipps, and Betsy had only one eye, but that one was a dandy. She could stand at her kitchen window, sixty feet from the McNoodle brothers' house, and by one glance at what the McNoodle's mother scraped from a plate into the garbage can she could tell what the McNoodles had had for dinner. And she did tell it, too. She was the worst old gossip on Long Island.

Again and again Betsy Phipps said she was sure there was something queer about the McNoodle brothers, but Philo Gubb did not pay much attention to her at first because she was always thinking everybody was queer. First she thought Orone McNoodle was surely an anarchist, because he wore his red hair in a pompadour; then she thought

he had a job as hooch hunter and bootleg trapper and had no time for nonsense—it kept him busy.

As a matter of fact, Orone McNoodle—the red headed one—was the gentlest and mildest man in the world. He was a radio fan, and everyone knows that radio fans are the meekest and sweetest people in existence—they'll stand anything.

They get that way by listening in to twelve different broadcasting stations every night and taking whatever those stations happen to be sending. Orone was the sort of radio fan who took everything that came, and enjoyed it because it came out of the air. He would sit before his loud-speaker and accept a bedtime story about Sammy Mud-turtle and a whang-

bang jazz piece entitled "Mamma's Bunion Kept Papa Awake Last Night," and a lecture on Mah Jong, and the time signal, and a Philharmonic recital, and the shouts of somebody selling autographed theatre programs, and never utter a peep. Anything that was radio was radio and he accepted it as such. A kiss or a kick or a rotten egg were all the same to him as long as they came through his loud-speaker. Every night he took twelve post-cards and wrote twelve messages, all just alike, to the twelve sta-

(Continued on page 342)

**P**HILLO GUBB, the famous correspondent school "deteckative," has come back this month. No doubt you have read Mr. Ellis Parker Butler's amusing stories of Philo Gubb. Here he is back in all his past glory. This month he has managed to get mixed up in a radio and bootlegging mystery which cannot fail to hold your interest. It is one of the best from Mr. Butler's pen. We promise you an interesting twenty minutes.—EDITOR.

Fenix McNoodle was a Russian Bolshevik because he began to grow a beard; then she was sure Orone McNoodle was a German spy because he had strung a radio aerial in his back yard. She was always thinking evil of the McNoodles, and finally she decided that the McNoodles were a couple of bootleggers and moonshiners and makers of hard liquor.

Philo Gubb did not pay much attention to her because she was always blabbing something or other at him, trying to make the McNoodles out to be criminals or worse, and

# Proper Antenna for Tuning

By F. CONRAD\*

**T**HE ability to hear a desired station alone, or "selectivity" as it is called, depends in part on the receiving apparatus and in part on the antenna system to which it is connected. Many believe that the better the antenna, the better the signals. This is true, but it does not necessarily mean that the best antenna is the largest. The function of the antenna is to transfer to the receiving apparatus the electric forces which are set up by the waves being transmitted through space. This receiving apparatus must discriminate between the electric forces due to the radio wave it is desired to receive, and the forces due to the undesired waves, among which are the waves from "Dame Nature" herself, or "static" as they are called.

The selective receiver is one that offers a high resistance to the flow of current which would be set up by the electric forces from undesired waves, and offers a low resistance path for the flow of current due to the electric forces from the waves it is desired to receive. In other words, it permits you to hear the stations you wish, and to tune out those you do not wish to hear.

The receptive ability of an antenna is, in general, determined by the height of its horizontal portion above the ground, or, stated differently, the strength of the electric forces induced in an antenna by the radio waves is proportional to the height of this antenna. Therefore, to tune out or discriminate between different waves, the selectivity or resisting power of the receiver to interfering waves would have to be increased as the antenna height is increased, while to receive an equal signal from a desired wave, the resistance in the receiving set to this desired wave, would have to be decreased as the antenna height is decreased.

Experiments have shown that when the antenna height is increased and a receiver, such as a crystal-detector set or a tube set not using regeneration, is used, the signal at first increases but soon reaches a maximum strength, which cannot be exceeded by further increase of antenna height. This height is such that the electric forces set up by the incoming wave is sufficient to drive through the receiving apparatus the full current strength which is equivalent to the received signals. To express it in another way, this

maximum current is that which would itself set up the same strength of radio wave around the receiving antenna as is induced by the transmitting antenna sending out the signals it is desired to hear.

A vacuum-tube receiving set, in which the principle of regeneration is employed, tends to reduce the resistance to the flow of current from a wave corresponding to that for which it is tuned. Therefore, if a regenerative receiver is used, it will be found possible to maintain the maximum strength of signal, even with a reduced antenna height. However, as the same resistance will be maintained by this receiver against undesired waves the reduction of height will therefore give a greater selectivity. Of course, in general practice it usually will not be possible to obtain quite the same strength of signal with the low as with the high antenna, as there is a certain amount of absorption or loss near the ground which tends to reduce the possible signal strength.

Should the location be such that the antenna is perfectly clear and free from surrounding objects, the low one will be found  
(Continued on page 312)

## Three Hundred Dollar Prize Contest!

**H**ERE is a brand new contest for readers of RADIO NEWS, particularly those musically inclined.

This is really a double-barreled idea for the reason that it is supposed to kill two birds with one stone.

To illustrate: There has been a lot of talk recently that radio broadcasting is killing the sale of sheet music. The argument that has been put up by the music publishers is that inasmuch as the public can hear any particular composition free of charge, no one would be interested in buying sheet music. The argument, absurd on the face of it, nevertheless has been upheld vigorously by the music publishers, as well as the authors; so much so, that they almost believe it themselves.

RADIO NEWS' argument is that if people hear a particular piece of music over the radio, sooner or later they will wish to buy the sheet music or the roll for the player piano, or the record for the phonograph. In other words, people who hear a particular composition will want to know more about it. This is our contention, and we are willing to back it up with our own money.

We will go further and show that we think it is perfectly possible that a particular composition can be popularized SOLELY by Radio without being sold at all through the usual sales agencies, such as stores selling sheet music, etc.

On the other hand, there do not exist today two pieces of music which we have in mind, namely, a good "Radio Jazz" and a good "Radio March." To be sure, we have all sorts of marches and all sorts of jazes, but what we wish particularly are two pieces of music that are especially adapted to be broadcast by Radio. If you are musically inclined, you will at once grasp what we mean. The pieces should have peculiar Radio characteristics. For instance, in Radio we have radio code. We are all familiar with the code signals going thuswise: dah-de-de-dah . . . . . Then everyone is ac-

quainted with the Radio squeal, the little birdlike flute-noises that we hear when the other fellow is trying to tune in. These two and a number of other sounds are characteristic of Radio and should be taken as a basis or theme for the new Radio compositions.

What we want, therefore, are two pieces of music, as mentioned before: one a composition which will be known as the "Radio March" the other one as "Radio Jazz." For each one of these compositions, we will pay to the success-

**\$300.00  
Prizes in Gold**

\$150.00 for a Radio March.  
\$150.00 for a Radio Jazz.

ful composer \$150.00 outright. In addition to this, a 10 per cent commission on the sale of the sheet music, roll music and record music, will be paid by us to the composers, on all sales made.

Through the RADIO NEWS organization, the two pieces, by arrangement with the broadcasting stations throughout the country, will be popularized on a scale never before attempted with any musical composition. At the beginning the sheet music will not be sold in music stores whatsoever, and can be had only by application to the broadcasting stations and to this office. All advertising will be done by Radio. At the end of six months, and at the end of the first year, the results of the experiment will be published by RADIO NEWS.

It should be understood, and it can be readily realized, that the nature of the contest is such that there can be only one prize for each composition; there are no second or third prizes. The judges who will pass on the compositions are the following:

### JUDGES

Hugo Riesenfeld, musical director and famous conductor of the *Rialto*, *Rivoli* and *Criterion Theaters* of New York.

Ted Lewis of the well known Ted Lewis Band and the *Ted Lewis Frolics*. The Jazz Master.

Leo B. Riggs, musical director of the *Hotel Astor* bands, N. Y. City.

Milton J. Cross, "Announcer AJN" of "Broadcast Central" "WJZ" New York, member Institute of Musical Arts, and member of Paulist Choristers.

H. Gernsback, Editor.  
Their verdict will be final. The Publishers, by awarding the cash prizes as outlined above, become the sole owners of the musical compositions, and bind themselves to pay all royalties as outlined above.

### Rules of the Contest

1. Each composition to be not longer than the usual four pages.
2. Contestants may send in more than one composition. There is no restriction as to number.
3. All compositions to be executed in ink in the usual manner, using the usual musical symbols.
4. Compositions to be entitled "Radio March" or "Radio Jazz," as the case may be.
5. Authors unable to write down music themselves, may have a musician do this for them.
6. All manuscripts to be submitted flat, not rolled.
7. All manuscripts not accepted will be promptly returned to the owners at the conclusion of the contest, provided sufficient postage is enclosed with the manuscripts.
8. All prizes will be paid upon publication.
9. This contest closes in New York on October 1, 1923.
10. Address all contributions to Editor, Radio Music Contest, care of this publication.

# A Super-Sensitive Two-Tube Receiver

By JOHN SCOTT-TAGGART, F. Inst. P., Member I. R. E.

**S**UPERLATIVES have become so common that I hesitate to describe the arrangement either as novel or super-sensitive. As regards novelty, we always have the type of person who has been using something like that for years, and, as regards super-sensitivity, one is competing with the man who hears all the broadcasting stations in the country on one valve with a loop aerial.

I have no desire to emulate the exploits of either type. Nevertheless, the arrangement about to be described is one which unquestionably gives very good results. We hear so much of super-sensitive circuits, and yet so little of such sets in use. Three and four-tube sets, apparently, have still to be used to obtain good results on a loud-speaker, and yet here is a two-tube circuit which will enable broadcasting to be heard 100 yards from a loud speaker at a distance of about 15 miles from a broadcasting station.

Different sizes of aeriels have been tried, and at this distance signals are quite audible in a room when using a loud speaker, and an aerial of only from 8 to 16 feet long, suspended from wall to wall in the room. Similar results are obtainable with a 2' 6" type of square loop aerial. Such results are quite good as the generality of circuits go.

As regards purity of signals received, no circuit could excel in this direction. One of the disadvantages of the ordinary Armstrong super-regenerative circuit, is that the modulation of the incoming signals is impaired, and the signals are often made rather mushy. Moreover, the Armstrong super-regenerative circuit is not efficient on wave-lengths much above the broadcasting band, whereas the ST-100 will work on any wave-length, and will also give excellent results with continuous wave signals.

Another point in connection with the Armstrong super-regenerative circuits, is that they do not work except on small loop aeriels. The experimenter is, therefore compelled to work on a much smaller antenna than he could possess. Although the ST-100 will work quite well on a coil aerial, as well, in fact, as an Armstrong super-regenerative circuit (except, perhaps, over very long ranges), yet the signal strength will vary with the size and height of the aerial. The better the aerial, the louder the results obtained. This is a very distinct advantage, because no one is particularly anxious to use a 2' coil aerial for reception when he can arrange an effective indoor aerial or one out of doors. Even in flats, a much better aerial may be obtained

than a 2' loop, and with this circuit it is possible to take advantage of whatever aerial can be erected.

As a receiver for portable purposes, it is ideal. I have for my own use a complete two-tube receiving outfit which packs into a fairly large attaché case. The batteries are all self-contained and dull-emitter valves are employed. With such a circuit, it is possible to receive 2LO (London), not only on telephone receivers, but on a loud speaker, up to 20 miles on even the smallest aerial.

Although it is more than likely that a number of experimenters have obtained equally good results, yet the number must be extremely small, and the apparatus they

use must be tricky to work, or else the majority of listeners-in would have adopted their arrangements. I can say with confidence that the arrangement here described is capable of being reproduced by any beginner with perfect confidence that excellent results will be obtained. The circuit, unlike many other super-sensitive circuits, is very stable. It does not produce howling noises, and undesirable capacity effects are absent, except perhaps when working on a very small loop aerial.

Across the plate of the tube  $V_2$  and the lower terminal of  $T_3$  is connected a fixed condenser  $C_3$  of .002 M.F. capacity. Across the plate of the tube  $V_1$  and the top terminal of the primary  $T_1$  of the transformer  $T_1 T_2$ , is connected a crystal detector, D. A piece of Hertzite, on which rested a light spring of No. 36 bare copper wire, was used for most of the experiments, but different crystal detectors were found to give good results. The Hertzite combination is very sensitive and reliable, but was inclined to be microphonic, the set responding to the slightest vibration, producing crackling noises in the loud speaker. A zincite-hornite detector, while not always as sensitive, is rather more robust.

Across the plate of the tube  $V_1$  and the lower terminal of the primary  $T_1$ , is connected a variable condenser  $C_2$  having a maximum capacity of about .0005 M.F. or .0001 M.F.; the actual value used with this set was .0005 M.F. This was found suitable for receiving on 450 meters, and would also tune the set up to almost 600 meters.

Across the grid and the ground is connected a fixed inductance coil  $L_2$ , which may either be a No. 50 or No. 75 honeycomb coil. Any equivalent coil could, of course, be used. The correct value of the coil  $L_2$  is important, and preferably different sizes should be tried. Nos. 25, 35, 50 and 75 should be kept on hand. For general purposes, it will be found that a No. 50 will give satisfaction.

The inductance coils  $L_1$  and  $L_2$  are coupled together if a regenerative effect is desired, but they may be kept separate without much decrease of signal strength. Whether the coils are coupled together or not, the connection to the coil  $L_1$  should be reversed, in order to see which way round gives the loudest signals. Whenever any alteration or adjustment in the circuit is made, the two condensers  $C_1$  and  $C_2$  should be slightly readjusted.

If the coils  $L_1$  and  $L_2$  are connected in a two-coil or three-coil holder, it is possible to have the coils either wide apart or coupled to each other.

### OPERATION OF THE SET

The operation of the set presents no particular difficulty. The coupling between  $L_1$  and  $L_2$  should normally be loose, and the condensers  $C_1$  and  $C_2$  varied until signals are heard. The crystal detector, of course, should be carefully adjusted beforehand. The filament rheostats,  $R_2$  and  $R_3$ , should also be varied, as an alteration of these often results in a great change in signal strength.

When small aeriels are employed, it will  
(Continued on page 314)

**W**E are pleased to present to our readers the new ST-100 Circuit, which will undoubtedly create much interest among the experimenters. The arrangement described is exceedingly sensitive and will receive broadcasting on very small aeriels and over long distances.

EDITOR.

### THE CIRCUIT

Fig. 1 shows one form of the ST-100 circuit. There are several possible modifications of this arrangement, and these modifications will be described in future issues of Radio News.

It will be seen that between the aerial and ground, we have a variable condenser  $C_1$ , a resistance  $R_1$ , an A battery  $B_1$ , and the secondary  $T_2$  of a step-up iron-core transformer  $T_1 T_2$ . The condenser  $C_1$  has a maximum capacity of .0005 M.F. or .001 M.F. The ad-

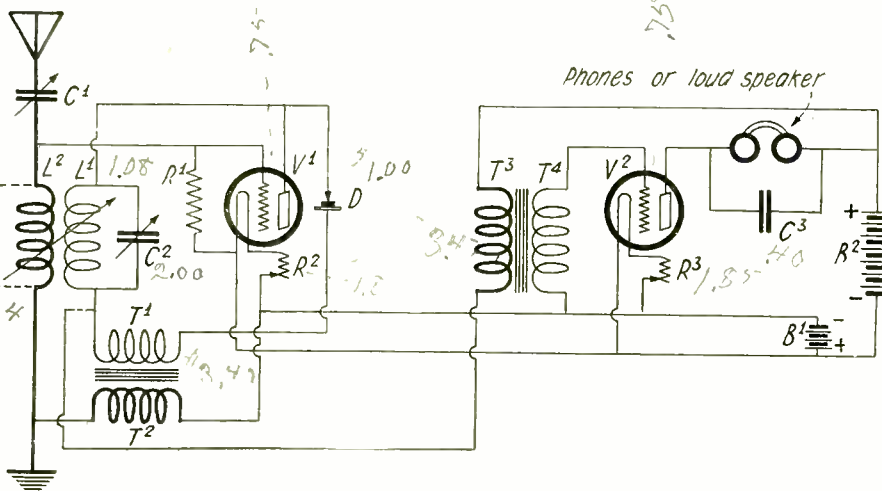

The New ST-100 Circuit. With But Two Tubes, a Loud-Speaker Can Successfully Be Operated on Stations a Good Distance Away. There Is No Distortion of Signals, as in the Case of a Super-Regenerative Circuit, Yet the ST-100 Parallels the Results of the Latter. A Loop Aerial Can Be Used Effectively if Desired.



# Detection

AN EXPLANATION OF HOW SIGNALS ARE MADE AUDIBLE BY RECTIFICATION.

By LOUIS FRANK

Part II

**I**N the former article of this series published in the August issue, the author discussed the most important methods of detection for radio waves whose amplitudes varied, that is for radio waves such as sent out by the radio telephone broadcasting stations, and the spark telegraph signals sent out by most coastwise sailing ships. These radio waves when photographed by some form of oscillograph have the appearance shown in Fig. 1. The subject of the present article is the detection of radio waves whose amplitudes do not vary but are constant, such as are sent out by arc sets, the powerful alternators used for trans-Atlantic signaling, and

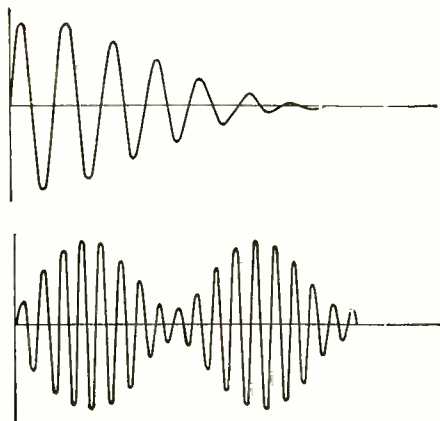

Fig. 1

Above: Damped Waves Produced by a Spark Transmitter. Below: Modulated Waves Produced by a Radio Telephone Transmitter.

the vacuum tube oscillators which are coming more and more into commercial use. These radio waves when photographed by an oscillograph have the form shown in Fig. 2.

The methods of detection employed for telephone and spark signals are not suitable for the so-called "continuous" or "undamped" waves which we are now discussing. The reason for this may be briefly stated as follows. It will be recalled from the last article on detection that there were given two conditions for detection: First, the radio waves must be rectified, and Second, they must be transformed so that they have audio (audible) frequency components. Now by using any of the methods previously described, the radio frequency waves which are undamped may be easily rectified, as shown in Fig. 3. However, unless some other means are employed, the current in the telephones will be the average current shown by the dotted line in Fig. 3, and

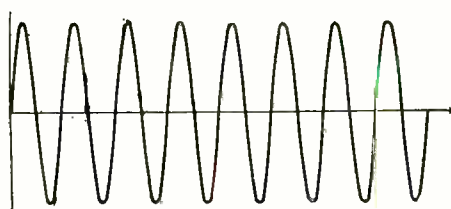

Fig. 2

Waves Produced by an Undamped Wave Transmitter.

since this is constant no sound will be heard in the phones. This is what is obtained when any of the methods previously described are used. As a result

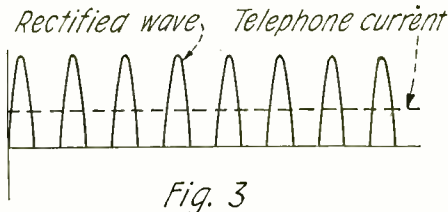

Fig. 3

A Continuous Wave Rectified Gives a Constant Telephone Current, Thus No Sound.

some other device or method must be employed to make these signals heard.

### CONTINUOUS WAVE (C.W.) RECEPTION

We will briefly take up some of the older methods for their historical interest first, and then we will consider the more important modern methods in detail. The very first method to come into use is the use of a "Tikker." This device was developed by Poulsen, the inventor of the Poulsen Arc which generates undamped radio waves. In this system of reception there was no necessity of employing a rectifier as will be understood from the following explanation of its action. The circuit is shown in Fig. 4. The usual receiving circuit LC is connected to an interrupter I and to a large condenser C1 and the phones. The interrupter I may be a fine wire which makes contact with a metal disc rotated by a motor. The metal disc is so arranged that the contact wire closes and opens the receiving circuit intermittently

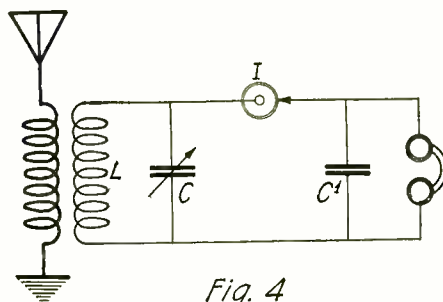

Fig. 4

A Circuit Employing a Tikker for the Audible Reception of Undamped Wave Signals. No Crystal Detector is Used.

depending upon the speed at which the motor rotates. When the tikker opens the circuit the received energy accumulates and builds up a high voltage across the receiving condenser C. When the tikker closes the circuit at I this voltage charges up the large condenser C, which then discharges through the phones. Thus if the tikker motor is rotated at an audio frequency speed the condenser C1 charges up and discharges at an audible rate. Thus a signal is heard in the phones.

This system has some similarity to the chopper method of reception with which the reader may be on speaking terms. In the chopper system, shown in Fig. 5, however, a rectifying detector is required in place of the large condenser C1 in Fig. 4. Here the chopper, which is es-

entially the same thing as the tikker, breaks up the continuous waves into groups and rectifies them. The groups are audio frequency groups and hence are heard in the telephones. The chopper system is used quite a lot today, especially in transmitting stations. For it is apparent that if a chopper may break up continuous waves at a receiver so that they occur at an audible rate, they may also be broken up at the transmitter and transmitted at an audible frequency. Thus when the waves are chopped up at the transmitter the usual methods of reception described in the last article may be used.

### THE ROTATING CONDENSER METHOD

A third method which is used by some experimenters is that of a continuously rotating variable condenser. In Fig. 6 let

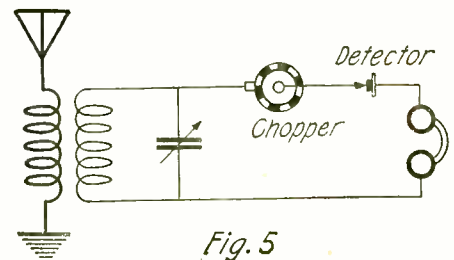

Fig. 5

A Circuit Including a Chopper and a Crystal Detector for the Audible Reception of Undamped Wave Signals.

us suppose that the movable plates of the condenser C are continuously rotated by a motor whose shaft is coupled to the condenser shaft. Then at one particular setting of the condenser the receiver circuit will be in tune with the incoming waves. When the rotating plates reach this setting the current in the receiver is maximum because the receiver is in resonance with the incoming signals. These received signals will therefore be rectified by the detector. If the speed of the driving motor is so arranged that the condenser plates are rotated into the resonance setting one thousand times every second, the incoming waves will be broken up into audible groups and will therefore be heard after rectification by the detector. Instead of receiving a continuous stream of undamped oscillations we now receive groups of oscillations, a thousand times per second, which may be heard. This is identical in principle with the previously described chopper system. The difference is that in the chopper system the circuit

(Continued on page 302)

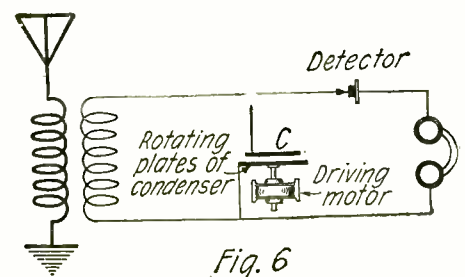

Fig. 6

A Rotating Plate Condenser Employed in Conjunction With a Crystal Detector in a Circuit for the Audible Reception of Undamped Wave Signals.

# Electrons, Electric Waves and Wireless Telephony

By DR. J. A. FLEMING, M.A., D. Sc., F.R.S.

## Part VIII



By Courtesy of Marconi Wireless Telegraph Co., Ltd.  
 Fig. 92. Half-kilowatt Valve Transmitting Set for Wireless Telephony as Arranged by Marconi Wireless Telegraph Company, Ltd. The Transmitting Valves are Shown in the Center Panel and the Receiving Valves on the Right-hand Bottom Panel.

It will perhaps be advisable first to explain the manner of using a two-electrode or Fleming valve to rectify high voltage alternating electro-motive force, or change it to direct voltage.

If we connect to the plate *P* of a two-electrode valve one terminal of a condenser *C*, the other terminal of which is connected through the secondary coil *S* of an alternating current transformer *T* to the filament *F* of the valve (see Fig. 90), and if we supply the transformer with low frequency alternating current, then the plate of the condenser which is directly connected to the anode or metal cylinder of the valve will become charged with negative electricity.

The reason is as follows. When the direction of the E.M.F. in the transformer circuit *s* is such as to make the plate *P* of the valve positively electrified, electrons are drawn out of the incandescent filament *F*, and neutralize this positive charge of the plate. The upper plate of the condenser *C* is then left negatively electrified. When the E.M.F. of the transformer reverses and the plate *P* becomes negative, it repels the escaping electrons and stops the emission from the filament. Hence, if the condenser *C* has a large capacity it will become a reservoir of electricity, and we can continually draw

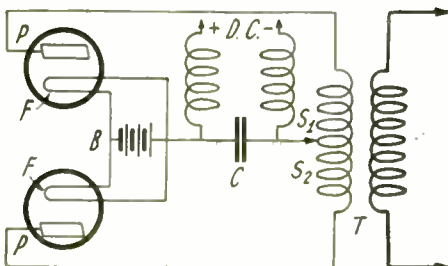

Fig. 91. Arrangement of Circuits for Rectifying Both Components of an Alternating Current Supplied by a Transformer *T* by Means of Two Fleming Valves. The Condenser *C* Then Supplies a Direct Current.

off a supply of negative electrons from its upper plate. As these electrons are supplied in gushes by the transformer, it is found advantageous to insert a spiral of insulated wire wound on a bundle of iron wires, called a choking coil or choker, as shown in Fig. 90. This serves to convert the intermittent gushes of electrons into a steady stream, which can be drawn off the *d c* terminals marked + and -.

In the above described arrangement we only utilize and rectify every alternate phase, or half of the alternating current energy. By the use of two rectifying valves and a transformer with a connection to the center of its secondary circuit, as shown in Fig. 91, we can rectify both phases, and convert all the alternating power of a transformer into direct current power. The two valves can have their filaments rendered incandescent by the same filament heating battery *B*. The reservoir condenser *C* has choke coils inserted in its exit wires marked *d.c.* + and -, and from these we can draw off direct current with a steady E.M.F.

The above appliances are all combined in a half-kilowatt wireless telephone cabinet designed by Marconi's Wireless Telegraph Company for radio-telephony. This consists of a cabinet in shape like a harmonium case or small piano, about 4 ft. high and wide, and 2 ft. deep. It contains all the

The articles appearing under the above title are a reproduction with some additions of the Christmas Lectures on Electric Waves and Wireless Telephony given by Dr. J. A. Fleming, F.R.S., at the Royal Institution, London, in December and January, 1921-1922. RADIO NEWS has been able to secure the exclusive serial rights of publication in this country. The articles are therefore copyright, and rights of publication and reproduction are strictly reserved.

transmitting and receiving gear effective for wireless telephony over a range of about 100 miles by day, but greater by night. This range corresponds to use with aerial wires of twin T type, 220 ft. long and 100 ft. high, with a natural wave-length of 360 meters. A view of the front and back of the cabinet is shown in Fig. 92.

The transmitting part comprises three thermionic valves, two of three electrodes and one two-electrode rectifying valve. One of these valves is shown in Fig. 93.

In the actual transmitter, a view of which is shown in Fig. 92, one of the three-electrode valves is the power or generating valve; the other is the control valve; and the two-electrode valve is used for rectifying the alternating current supplied by a transformer in one of the lower cupboards, taking its primary current from a rotary converter, which transforms direct electric current into alternating current at a frequency of 150 cycles and 85 volts E.M.F.

The diagram of connections is shown in

Fig. 94. It will be seen that the alternating current supply (A.C.) is fed into an alternating current transformer called the power transformer, and also into two smaller transformers which step down the voltage, and supply current at 12 volts for heating the filaments of the three valves. The electromotive force of the power transformer is rectified by the two-electrode valve on the right-hand side of the diagram, and used to charge two reservoir condensers connected to a smoothing choking coil, and these condensers supply a steady or direct high voltage to the plates or anodes of the two three-electrode valves on the left of the diagram. The valve marked "power valve" has its plate and grid circuits coupled through a

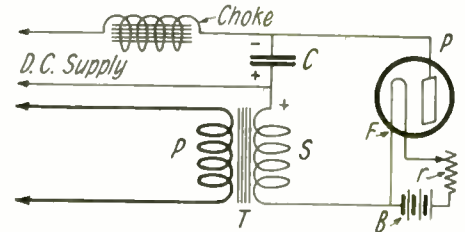
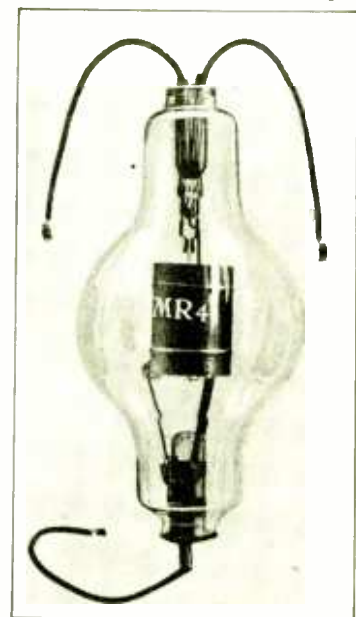

Fig. 90. Arrangement of Circuits for Rectifying an Alternating Current Supplied from a Transformer *T* by Means of a Fleming Valve and Condenser *C*.

reaction coil, and high frequency oscillations are therefore created in the coil *L*, to the upper end of which is attached the aerial wave *A*, and its lower end to an earth plate. Continuous or undamped carrier waves are accordingly radiated from the aerial.

The amplitude of these waves is controlled by the microphone *M* in conjunction with the control valve (middle). It will be seen from the diagram that the grid of this control valve is connected to the secondary terminal of a transformer, in the primary circuit of which is a 3-cell battery and the carbon microphone *M*. On speaking to this microphone the electric potential of the grid of the control valve is varied in accordance with the wave form of the aerial speech waves, and this in turn fluctuates the plate or electron current in the control valve. These variations in the plate current are caused to affect in like manner the potential



By Courtesy of Marconi Wireless Telegraph Co., Ltd.  
 Fig. 93. Large Three-Electrode Transmitting Thermionic Valve for Generating High Frequency Continuous Currents

of the plate of the generating valve, and therefore the amplitude of the carrier waves emitted from the aerial. Accordingly we have the wave form of the speech sounds impressed upon the amplitude or height of the carrier waves and the transmitter affects in like manner the current in the distant receiver circuits.

This plant is designed to operate with wave-lengths of 1,000 or 2,000 meters, and it is called a half-kilowatt plant because it employs about 500 watts in electric power to operate it. In more powerful transmitters the power valve is duplicated, or there may be three or more power valves, and two or more control valves. The necessary high voltage for the anodes or plates of these valves may be obtained from high voltage (1,000—2,000 volts) direct current dynamos, and in the case of aeroplanes the small high tension dynamo is driven by a little wind-screw or windmill caused to rotate by the rush of the aeroplane through the air (see Fig. 95).

This dynamo may have two separate armatures, one providing a current of about 0.1 ampere at 1,500 volts for charging the valve anodes, and a low voltage armature providing a current of 5 amperes or so at 7 or 8 volts for incandescing the filaments of the valves.

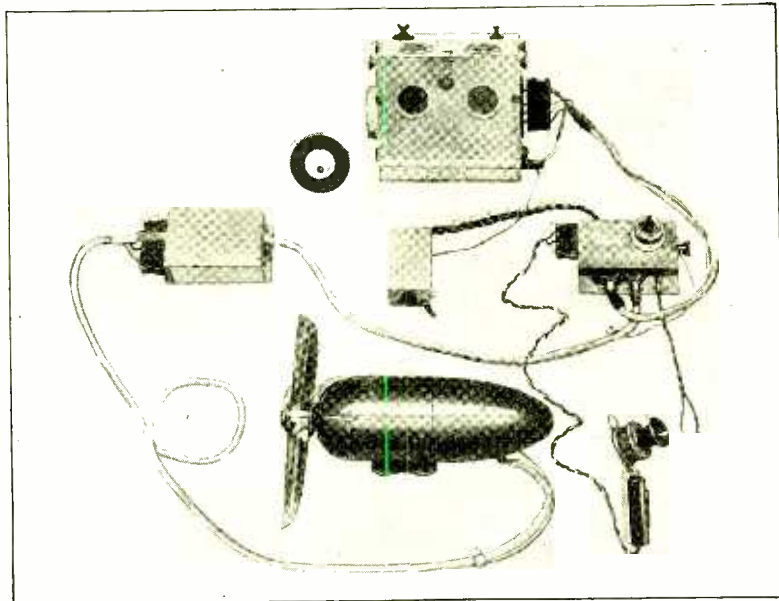

By Courtesy of Marconi Wireless Telegraph Co., Ltd.  
 Fig. 95. Aircraft Wireless Telephone Set as Made by Marconi Wireless Telegraph Company. In the Center of the Illustration at the Bottom is Shown the Small Direct Current Dynamo Driven by a Wind Screw Which Supplies the High Plate Voltage for the Generating Valves.

An ingenious part of the equipment for aircraft in the aircraft plant of Marconi's Wireless Telegraph Company is the arrangement of remote control, in which all the valves and supply circuits of the transmitting part of the arrangement are brought into operation merely by pressing a switch on the handle of the speaking microphone, which is the only part the aeroplane pilot or observer need touch, or has within reach.

The layout of apparatus shown in Fig. 95 gives some idea of the apparatus as installed in an aeroplane. Connections are made by means of heavily insulated cables having plugs at their extremities, the instruments to which the connections have to be made being provided with sockets to receive them. The transmitter is similar to an ordinary telephone transmitter in shape, with the exception that there is no receiver attached, its place being taken by the head receiver telephones worn in the operator's cap.

**RECEPTION OF WIRELESS TELEPHONIC SPEECH**

We have then to describe the arrangements in the practical receiving apparatus. The use of a single rectifying valve or a crystal in the receiving circuit as already described is only suitable for short ranges of 10 or 20 miles, or so, from fairly powerful transmitters. In actual wireless telephony over great ranges it is necessary to

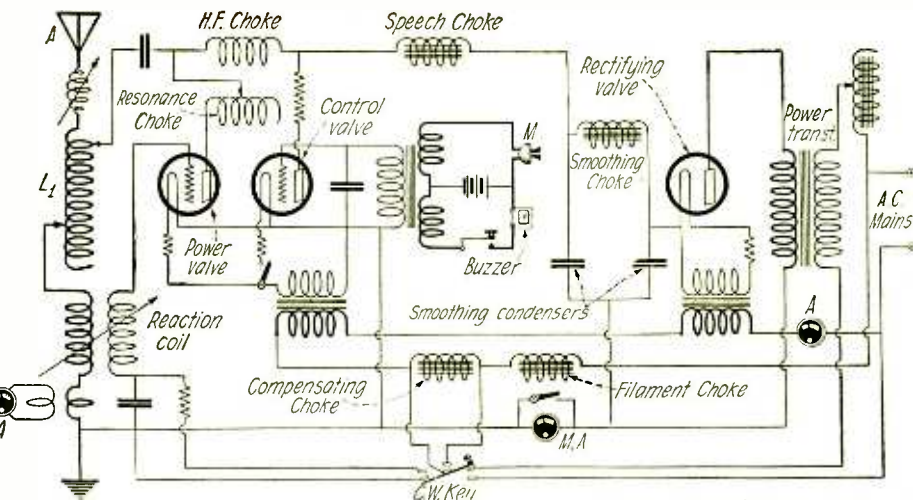

By Courtesy of Marconi Wireless Telegraph Co., Ltd.  
 Fig. 94. Diagram of Connections in the Transmitter Part of the Half-kilowatt Wireless Telephone Apparatus Shown in Fig. 90.

employ amplifying valves to magnify the oscillatory currents in the receiving circuits.

We have already explained that this amplification can take place on the high frequency currents set up in the aerial wire

plate current of that valve supplied by the high tension battery as already explained.

This plate current may include the primary coil of a transformer consisting merely of two insulated wires wound on a bobbin, but without any iron core.

The secondary circuit of this transformer may have its terminals connected respectively to the grid and filament of a second valve, and the same arrangements may be made for a third valve. If, then, the first valve and associated transformer magnify the grid-potential variations say five times, the coupling of two valves and transformers will magnify it 25 times, and a third set 125 times, and so on.

We can, in this manner use several amplifying valves for radio amplification.

If we employ two-coil transformers as shown in Fig. 96, we need then only one high tension battery or dynamo to supply the high potential for the anodes or plates of all the amplifying valves. It is then necessary to explain in the next place the methods by which the three-electrode valve operates as a detector of oscillations. The reader will bear in mind that the carrier electric waves which arrive from the sending station are high frequency electric waves of a certain wave-length and amplitude, or wave height. The effect of speaking to the microphone in the transmitting plant is to alter the amplitude of these waves, but not their wave-length. The amplitude varies in accordance with the wave form of the speech sound, so that we may say that the oscillations produced by the carrier waves in the receiving aerial consist of very rapid or high frequency electric currents, which also have slow or low frequency variations of amplitude superimposed. These slow variations of current correspond to the speech waves made at the sending end. The radio-amplification increases or magnifies these currents all in the same ratio.

We have then to impress these slow variations upon a receiving telephone. It would be no use, however, to insert a telephone receiver in the plate circuit of the last radio-amplifying valve, because a telephone re-

and associated circuits by the carrier waves, or it may be effected after rectification of the high frequency currents into low frequency or speech frequency varying currents. The former is termed *radio-amplification* and the latter *audio-amplification*. In the case of radio-amplification the feeble currents set up by the carrier waves in the aerial wire A (see Fig. 96), are caused to induce other similar currents in an associated and tuned coupled circuit, comprising a condenser C and inductance coil S. A three-electrode valve has its grid and filament respectively connected to the terminals of the tuning condenser C.

The variations of potential thus produced in the grid cause similar changes in the

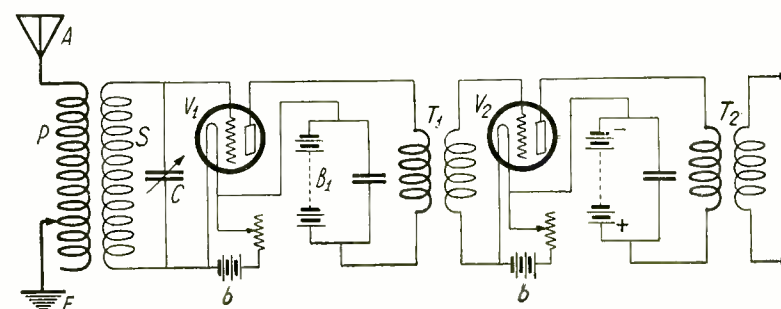

Arrangement of Two or More Amplifying Valves for Magnifying the Feeble Oscillations in the Aerial Wire A. V1 and V2 are the Thermionic Amplifiers, T1 and T2 the Coupling Transformers and B1 and B2 the Plate Batteries.

ceiver contains a coil of wire of many turns wound upon the iron pole pieces of a magnet. Such a circuit has a very large inductance, which means that rapid changes of current cannot take place in it. Hence the telephone coil will not permit the pas-

In Fig. 97 in the upper diagram (a) the ordinates of the curve represent the high frequency current in the receiving circuit as magnified by the radio-amplification. This current has low frequency variations of amplitude superimposed upon its high fre-

formation of low frequency oscillations. We can thus employ two or three audio-amplifying valves and put the telephone receiver in the plate circuit of the last valve, as shown in the diagram in Fig. 98.

A multiple valve receiver may therefore comprise two or three radio-amplifying valves, a detector valve, and one or two audio-amplifying valves. The Marconi Company have designed a seven-valve receiver, in which six of the valves are radio-amplifying, and the seventh and last valve the detector valve (see Fig. 99).

A simple form of valve-receiving circuit comprises a single detector valve, the grid of which is connected to one terminal of the tuning condenser in the receiving circuit, and also a single audio-amplifying valve with a telephone receiver in its plate circuit. The necessary negative potential is given to the grid of the detector valve by means of an arrangement called a *potentiometer*.

A long fine wire wound on a suitable support has its terminals connected to a few cells of a battery, which may be the filament heating battery. By means of a sliding contact we can connect a point on this wire to the grid, and by changing the position of this slider apply to the grid a nega-

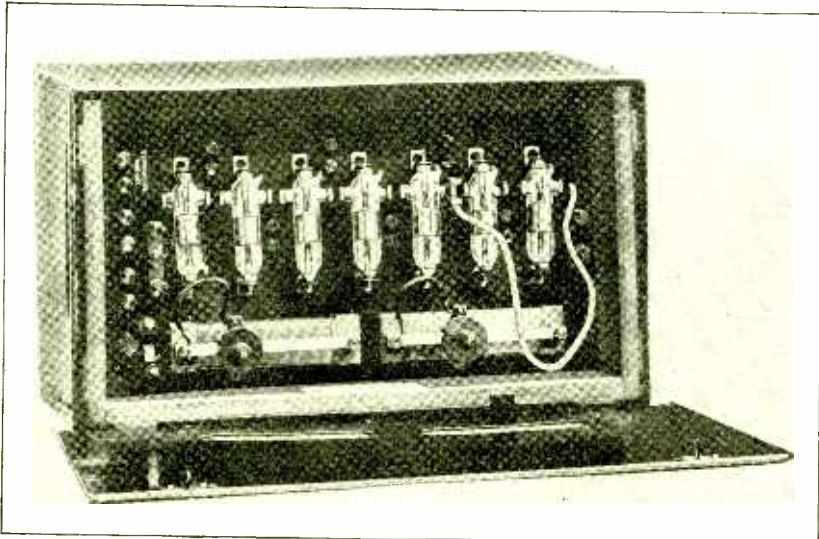

By Courtesy of Marconi Wireless Telephone Co., Ltd.

Fig. 99. A View of a Seven-Valve Receiver as Made by the Marconi Wireless Telegraph Company.

sage through it of a high frequency alternating current. It offers too much *impedance*, as it is called, to such a current. Moreover, the mean value of these high frequency oscillations of varying amplitude is constant. We have therefore to insert in the valve receiving arrangement a rectifying valve to change these high frequency currents of fluctuating strength or amplitude into pulsating electric currents always flowing in one direction. This can be done by taking advantage of the form of the characteristic curve of the valve.

quency, but the mean value of the current is always the same. The second diagram (b) shows the effect on this current of the detecting valve, the grid of which has a steady negative charge given to it. Since the electron current cannot then be much decreased, the effect of the additional negative charge given to the grid produced by the superimposed alternating potential is extremely small, but the effect of the positive charges is to increase the electron current.

The mean value of the current therefore fluctuates, as shown by the ordinates of the dotted line in diagram (b). If then the plate circuit of the detecting valve has included in it the coils of a receiving telephone, the rapid variations of current would produce no effect in the telephone, but the slow variations of the mean current cause the diaphragm of the telephone to vibrate, and its motions correspond to the slow or audio-variations in the amplitude of the carrier waves. Hence the receiving telephone will reproduce the speech sounds made to the transmitting microphone, the energy being conveyed by the carrier waves as above described. We can also employ one or more amplifying valves to increase the amplitude of the rectified low frequency speech current variations, which is termed audio-amplification.

For this purpose one or more three-electrode valves are placed after the detector valve, and have induction coils inter-connecting their grid and plate circuits exactly as in the case of the radio-amplifying valves. These induction coils or transformers may have cores composed of bundles of fine iron wires, which increases their effect, and has no disadvantage in the case of the trans-

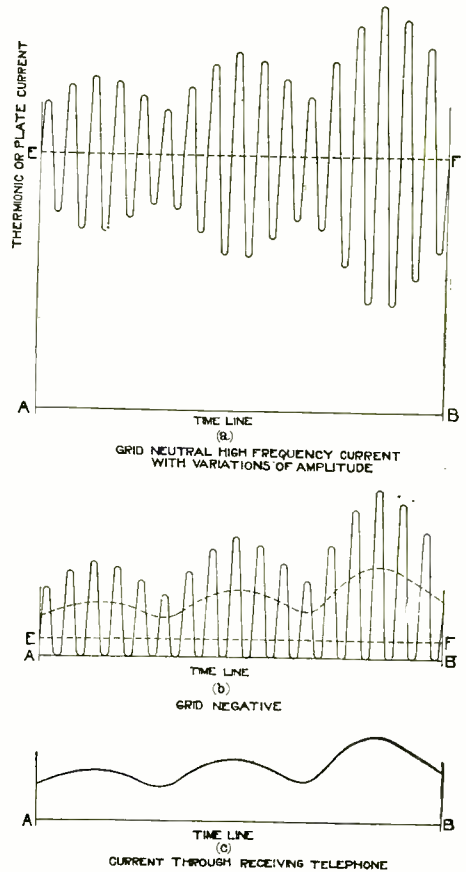

Fig. 97. Diagrammatic Representation of Rectification and the Mean Value of the Rectified Currents Which Operate the Diaphragm of the Telephone.

It has already been explained that when we give to the plate or anode of the valve a positive potential, electrons are drawn away from the filament, and this electron stream is generally increased by giving the grid a still greater positive charge. There is, however, a limit to this electron current which is fixed by the temperature of the filament, and it cannot be increased beyond a certain amount at any given filament temperature. This limiting current is called the *saturation current* at that temperature. Corresponding to this saturation stage the characteristic curve has, therefore, a bend or change of direction. In the same manner, if we give the grid a gradually increasing negative charge, and thus steadily diminish the electron flow from the filament, we find the characteristic curve at the lower end bends over. Suppose, then, that we give the grid of a valve a negative potential, say about four volts compared with the filament, and then superimpose on this steady grid voltage a feeble high frequency alternating voltage. It will be clear that when the small alternating potential makes the grid negative, the thermionic current or electron stream from the filament cannot be much reduced because the grid has already been made strongly negative. When the alternating potential applied to the grid is positive, then the electron stream is sensibly increased. The result, then, of imposing a feeble alternating potential on the grid in addition to a steady negative potential is to increase on the whole the electron stream from the filament.

If, then, the alternating potential suffers changes of amplitude, as it does when the carrier electric waves are changed in height by speaking to the microphone, in the transmitter, the electron stream of the detecting valve will experience similar increases in mean strength, although there are also rapid variations in the current. The actual changes produced in the currents will be best understood by a series of diagrams.

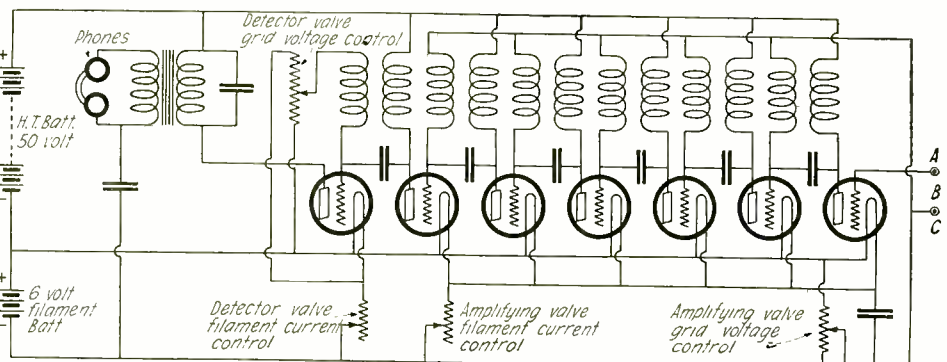

Fig. 98. Scheme of Circuits of a Seven-valve Thermionic Receiver With Amplifying Valves and Detector or Rectifying Valve.

tive potential, or two or three volts or more as required, to bring the plate or electron current of the valve to that point on the characteristic curve which corresponds to the beginning of the lower bend of the curve.

In order that telephonic speech may be transmitted without distortion, it is essential that the radio-amplifying valves should have a characteristic curve which is nearly straight or flat in the central part. It is only under this condition that the complicated changes in the plate current will follow exactly the complicated changes in grid potential, and hence amplify without distorting the wave form of the oscillatory currents. This result is achieved by certain precautions in the design of the amplifying valves.

We have already explained that in a valve transmitter for wireless telephony there must be a valve, the plate and grid circuits of which are coupled inductively to produce high frequency oscillations in the plate circuit and radiate carrier waves from an associated aerial as in Fig. 101. We have then to modulate the amplitude of these carrier waves by means of a carbon microphone in accordance with the wave form of the speaking voice. One way of doing this is by coupling a microphone *M* inductively, that means by means of an inductance coil or transformer to the plate circuit of the generating valve as shown in Fig. 101. This method has disadvantages in practice. A better method of varying the amplitude of the carrier waves by means of the speech microphone has been called *choke control*. It has been found very suitable for the telephone transmitters of airplanes on account of its great simplicity.\* It employs a power and a control valve, which both derive their filament heating and plate currents from the same low and high voltage batteries (see Fig. 102). The plate or anode of the control valve is connected to one end of a large inductance or choking coil having an iron core, marked *L* in the diagram. The high frequency currents set up in the aerial wire by the power valve cannot pass through this choking coil, but find their way to earth through a condenser *C*.

The steady or direct current from the high voltage battery marked *H.T.*, can, however, pass through the choking coil. When speech is made to the microphone the potential of the grid of the control valve is varied, and also low frequency variations are produced in the plate current of the control valve. These changes of current strength produce large variations in the potential at the upper end of the choking coil *L*, which increase or diminish in a very marked and corresponding manner the plate current of the power valve. These surges react through the inductive coupling of the

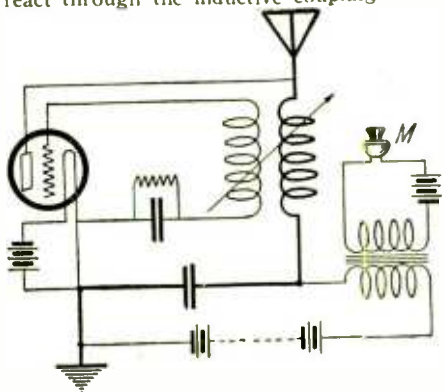

Fig. 101. Circuits of a Simple Form of Wireless Telephone Transmitter With the Microphone *M* Inductively Connected to the Plate Circuit of the Valve.

\* See Major C. E. Prince, O.B.E., "Wireless Telephony on Aeroplanes."—"The Journal of the Institution of Electrical Engineers." Vol 58, p 377, May, 1920.

grid and plate circuit of the power valve upon the grid potentials. Hence the effect of speaking to the microphone is to make large percentage changes in the amplitude of the high frequency oscillations set up in the aerial, and therefore upon the amplitude of the radiated waves.

**DUPLEX WIRELESS TELEPHONY**

Another matter of considerable importance

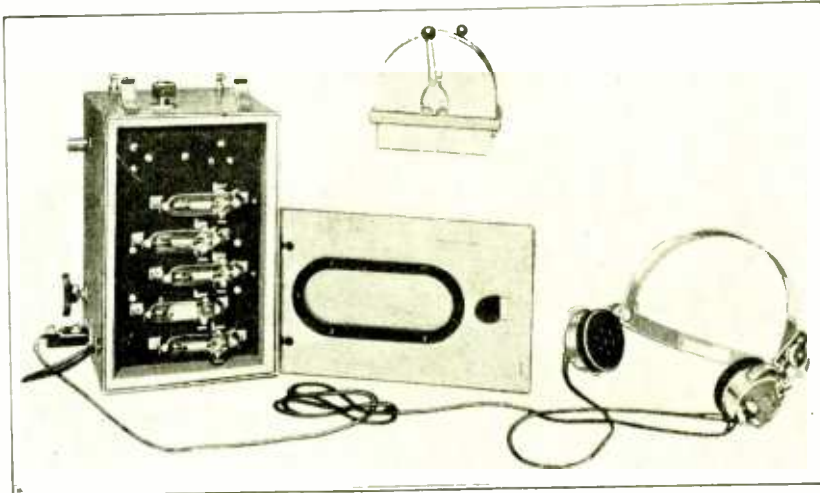

By Courtesy of Marconi Wireless Telegraph Co., Ltd.  
Fig. 100. Aircraft Receiving Set Comprising Three H. F. Amplifying Valves, a Detecting Valve and One L. F. Amplifying Valve Connected to the Head Phones Through an Induction Coil.

in connection with wireless telephony is the arrangements necessary to allow the two correspondents to "cut in" and interrupt each other in course of a conversation. We know that when two people are conversing through a single speaking tube they have to be careful not to interrupt each other, for

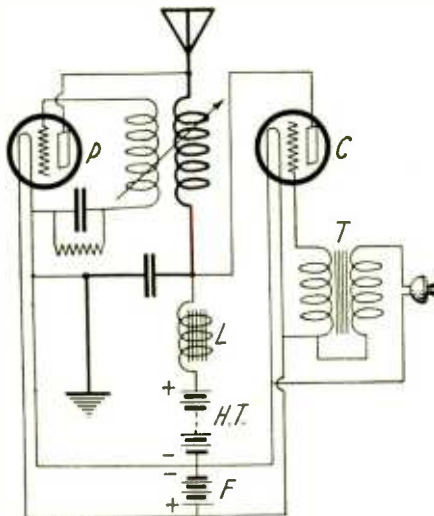

Fig. 102. Arrangement of Circuits in a Wireless Telephone Valve Transmitter Called a "Choke Control" Because it Employs a Choking Coil *L* or Large Inductance.

if both try to speak at once, or both listen at once, only confusion results. On the other hand, in the ordinary use of the exchange telephones we listen and speak at the same time. The listener can cut in with an interjection or question, or assure the speaker he is hearing, or ask for a word or sentence to be repeated. In the first forms of wireless telephony this cutting in was impossible. The aerial wire at each station had to be switched over from the transmitter to the receiver as required, and each correspondent had to be certain his distant colleague was ready to listen before he began to speak. This difficulty is to some extent obviated by the use of two slightly different wave-lengths for sending and receiving, and the separation of the sending and receiving stations at each post by a certain distance. This was done in the case of the wireless telephone demonstrations across the North Sea conducted by Marconi's Wireless Telegraph Company between Southwold on the east coast of

England and Landvoort, near Haarlem, in Holland, in 1921.

The distance between these places is 112 miles. At each place a transmitting and receiving station was established about 700 yards apart. Let us call these stations *T*<sub>1</sub> and *R*<sub>1</sub> in England, and *T*<sub>2</sub> and *R*<sub>2</sub> in Holland. The station *T*<sub>1</sub> telephones to station *R*<sub>2</sub> with a wave of 98 meters wave-length,

and the station *T*<sub>2</sub> transmits to *R*<sub>1</sub> with a wave 94 meters wave-length. This difference of wave-length (4 meters) was found to be sufficient to prevent the transmitter "jamming" the near-by receiver on the same side. At each transmitting station there was a valve transmitter made as above described, and a transmitting aerial 18 meters high, in which was created an aerial current of 5-8 amperes, which was modulated by an ordinary telephone exchange microphone.

The total power taken up by the transmitter was about 5 kilowatts, and of this 10 per cent, or 0.5 kilowatt, was radiated from the aerial in the form of carrier waves. Underground wires were brought from the receiving station to the transmitting station, so that the actual speech and hearing on each side of the sea was conducted from one place, and the receiving valves could have their filament currents and high voltage circuits switched on from the speaking station. In this manner ordinary telephonic conversation was carried on perfectly.

The problem of duplex wireless telephony, meaning by that the ability of the two conversationalists to speak and hear at the same time and "cut in" as they please, cannot be considered as completely solved by the two-wave and separate station system, because such method could not be applied in the case of airplanes or ships for want of space. Accordingly the problem has engaged much attention. The difficulty of it will be realized when it is noted that in many cases where wireless telephony is of the utmost importance, as in speaking to or by airplanes from or to the ground station, only a single aerial is practicable on the airplane, and therefore the act of sending sets up strong oscillations in it, which, if they have access to the receiving apparatus tuned for the same frequency, may completely jam the latter and set it out of order. Hence the real problem is to find a method of connecting the receiving apparatus to the aerial in such a fashion that the strong oscillations set up on sending shall not have access to it.

One solution which has been suggested, but which is only an imperfect solution, is that often called the quiescent aerial. In this case the permanent high frequency oscillations are not maintained all the time in the sending aerial and modified in amplitude by the speech microphone on speaking, but the high electromotive in the plate circuit of the generating valve is applied only by the microphone when it is actually in operation

(Continued on page 294)

# Multi-Layer Coils

AN ACCOUNT OF THE THEORY AND PRACTICE OF ALL THE MOST USEFUL TYPES OF CONCENTRATED INDUCTANCES.

By G. P. KENDALL, B.Sc.

IN beginning the consideration of the various types of multi-layer coil, I wish particularly to impress upon my readers the fact that each type is of necessity a compromise between two opposing factors. The efficiency or otherwise of any particular type depends very largely upon a satisfactory balance having been achieved between those factors, and if the amateur will realize clearly what the balance should be he will, I think, waste no more of his

between them are kept well apart in the coil, and in which all turns are spaced out from their neighbors as much as is possible without making the coil too bulky. There are many such systems, and I propose in later contributions to explain some of the best of them.

The essential point to grasp is that there must be spacing between the turns; no coil which appears to be a solid mass of wire, with considerable depth and breadth, can possibly be really efficient, no matter how it is wound. Since in most systems of multi-layer winding the spacing is produced by some arrangement of crossing turns the actual amount of spacing-out depends in part on the thickness of wire used, and this should be noted when examining a coil. Also, when winding your own, use as thick a gauge as reasonable limits of the size of the coil will allow. This is important, not merely because it reduces the internal capacity of the coil, but because it helps to keep down its resistance, and hence the damping of any circuit in which it is connected. This matter of the gauge of wire to use is one to which the amateur would do well to pay greater heed, for much efficiency may be lost by the use of unduly fine wire.

In this connection it may be well to give some definite guidance, and I append a table giving the required information:

Of the two, pile-winding usually produces a coil of least internal capacity, but it is not a sufficiently compact system for coils of very high inductance, and for these the slab coil is generally preferred. The latter type is extremely compact, very easy to wind (or cheap to buy, as the case may be), and, in spite of its only tolerable efficiency, it may be recommended for long-wave tuning to the beginner who wishes to put together as cheaply and easily as possible a set which will work, and which can be improved later. If the reader would prefer to adopt at the beginning a somewhat more troublesome but considerably more efficient type of coil, he is advised to wait for the next installment of this series, in which will be described the "lattice" coil and a modification thereof which I have devised and which I find superior to any of the coils now on the market.

## THE SLAB SYSTEM

The slab coil consists of a flat disc of wire, varying in size from perhaps 2 in. to 5 in. in diameter, and from  $\frac{1}{8}$  to  $\frac{3}{8}$  in. in thickness, held together by paraffin wax or varnish. The process of winding is extremely simple: a wooden former or bobbin is used which is very similar to those employed for winding the sections of spark coils, and the wire is run in quite irregularly until a coil of the required size has been produced. The former is then soaked in a bath of melted wax, taken out and cooled, and the coil taken out by separating the two halves of the wooden bobbin. The necessary details for the construction of a simple former are given in Fig. 1.

To wind slab coils with the maximum of ease some means of rapidly revolving the former is required; the one illustrated is intended to be held by its central spindle in the chuck of either a lathe or a breast-drill held in a vice. By either of these methods the wire can be run in at quite a high speed, and large coils wound in a few minutes. When the required amount of wire has been wound in secure the end and soak the former in melted wax until bubbles cease to rise, then take it out, drain out the superfluous wax, and allow to cool until it is only slightly warm. Next slacken off the clamping nuts of the former, and separate the coil from the wooden discs by running a hot table-knife round between them. The

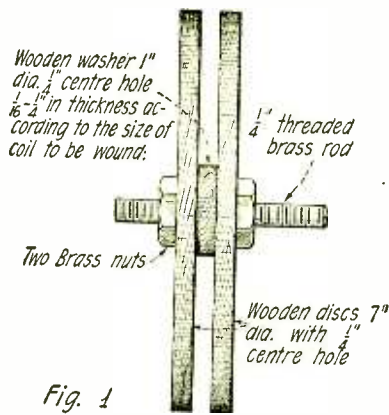

Fig. 1 Details for the Construction of a Simple Former Used for Making Slab Coils

hard-earned cash upon inefficient coils in which it scarcely exists. (It should, perhaps, be explained at this point that the object of this series of articles is, first, to provide instructions for the winding of various types of coil, and, second, to give sufficient insight into their principles to enable a wise choice to be made if coils are purchased.)

Let us consider, then, what are the two opposing factors between which a satisfactory compromise must be achieved to produce a good multi-layer coil. They are, briefly, efficiency and compactness, and they are opposed in this sense: the whole object of the multi-layer coil is to obtain compactness—that is, we wish to coil up a large quantity of wire in a small space—yet we know that the efficiency of a tuning inductance depends, among other things, upon keeping its internal capacity as low as possible, which can only be achieved by keeping well separated from each other all turns between which there is much difference of potential. Thus, turn No. 20 must not lie side by side with turn No. 1, though turn 5 and turn 1 may do so without much harm resulting. The worst possible arrangement would be to wind a layer of, say, 100 turns upon a tube, then over this another layer, and so on until the required number of turns had been wound on. A moment's thought will show why this arrangement of turns is bad, and will enable the reader to appreciate the statement that the best possible system of winding, judged from the internal capacity point of view, is the simple single-layer type, in which there is very little difference of potential between adjacent turns. From the foregoing it will be grasped that the difference of potential between any two turns depends upon the number of turns separating them electrically in the winding. Thus, there will be a comparatively small difference of potential between, say, the first and third turns, and a comparatively large one between the first and fiftieth.

It follows, then, that a good system of multi-layer windings is one in which turns with a considerable difference of potential



Fig. 2 Fig. 3

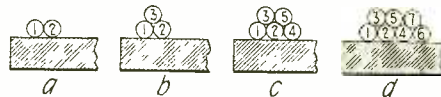

Fig. 4

Fig. 2 Shows a Section of a Three-Pile Winding; Fig. 3 of a Three-Layer Winding; Fig. 4 Shows the Successive Stages in a Two-Pile Winding.

| Wavelength.      | Size of Wire. |
|------------------|---------------|
| 300-1,000 meters | No. 22        |
| 1,000-5,000 "    | No. 24 or 26  |
| 5,000-20,000 "   | No. 30        |

It will be noted that for the longer waves a fairly fine wire is indicated, while a thick one is recommended for short waves. This is simply because long wave coils must contain a large number of turns, and would be of very large size if they were not wound with fine wire, whereas in the short wave coil, with its small number of turns, it is possible to secure greater efficiency by the use of thick wire.

It is not, I think, generally realized that the basic principles of the "slab" and the "pile" systems of coil-winding are essentially the same: in each we find that although turns between which there is much difference of potential are fairly well separated, there is no spacing between adjacent turns other than that provided by the insulation of the wire. Hence, while fair efficiency can be obtained in properly wound examples, these systems do not give the best possible results.

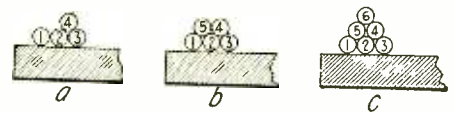

Fig. 5



a

b

c

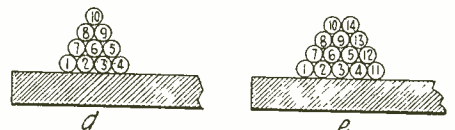

d

e

Fig. 6

Fig. 5 Shows the Formation of a Three-Pile Winding, and Fig. 6 of a Four-Pile Winding.

coil can then be easily removed when the former is taken apart. (Do not heat that knife in the fire; dip it in boiling water.)

A series of slab coils suitable for long-wave tuning may be wound with No. 30 double cotton-covered wire with the following numbers of turns: 500, 750, 1,000, 1,250, 1,500.

**THE PILE SYSTEM**

Pile-winding differs from the slab method mainly in that it produces a cylindrical coil, and that the turns are arranged in a definite order. It bears a considerable superficial resemblance to ordinary layer-by-layer winding, the distinction being that in pile-winding the turns are wound on so as to bring together only those between which there is a small difference of potential, and to keep others separated. This is actually done by winding on all the layers at once, instead of one by one; one turn is wound upon each layer in rotation until the coil has grown to the necessary size. Thus, if a three-layer pile-wound coil is being made, the wire will be wound on in this order: first, a turn on the bottom layer, then one on the second layer, and then one on the third, after which the wire returns to the bottom layer and the process is repeated. Figs. 2 and 3 will probably convey a clearer conception of the method than any verbal description. Fig. 2 is a section of a "three-pile" winding, and Fig. 3 is a section of a three-layer winding in which the layers have been wound on separately. The numbers within the circle representing the turns of wire indicate the order in which the turns were wound on.

Pile-winding is naturally somewhat more difficult than the previous method, and a certain amount of skill has to be acquired before it can be done easily and quickly. The process is rendered considerably easier by the use of a suitable gauge of wire, since the thicker wires are too stiff for convenience and the thinner ones not stiff enough for the turns to remain where they are placed. Nos. 24 to 28 will be found to be the easiest for pile-winding.

For the first attempt a two-pile winding should be tried, since this is the easiest for a novice to tackle. The method of procedure follows: first secure the end of the wire to the tube upon which the coil is to be wound (by passing it through two holes), and then wind on two turns side by side. Next, keeping the wire tight, hitch it back and wind the third turn on top of the first two. On the completion of this turn take the wire down on to the former again and wind turn No. 4 beside turn No. 2. Turn No. 5 will then be wound on beside No. 3. No. 6 beside No. 4, and so on, adding turns alternately to the top and bottom layers until the coil is complete. Fig. 4 shows these operations in stages and should make the matter clear. When the coil is finished it may be either waxed or varnished with shellac and well baked.

To wind a three-pile coil the procedure is as indicated in Fig. 5; while the beginning of a four-pile winding is shown in Fig. 6. A greater number of layers than four, or perhaps five, is not advisable, partly on account of practical difficulties in winding and partly because the self-capacity of the coil becomes excessive if a greater depth of winding is used.

In conclusion it should be pointed out that

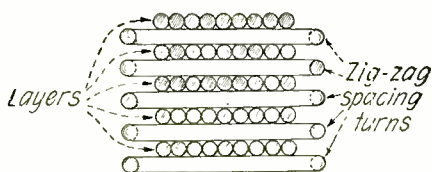

Fig. 8. Section of a Lattice Coil Winding. Note the Zig-Zag Turns that Space Each Layer of Wire.



Fig. 7. Specimens of Duo-Lateral and Lattice Coils. Note the Track of the Zig-Zag Spacing Turn in the Lattice Coil.

the pile-wound coil has one point of superiority over all other multi-layer types: it is quite easy to calculate its inductance with an accuracy sufficient for most pur-

|      |      |
|------|------|
| 3.00 | 0.86 |
| 3.50 | 0.88 |
| 4.00 | 0.90 |
| 5.00 | 0.91 |
| 6.00 | 0.92 |

**THE LATTICE COIL**

Taking into account its efficiency and its ease of winding, the "lattice" coil is perhaps the most suitable multi-layer for general amateur use. Its construction is very simple, for it is merely a layer-by-layer winding, the layers of which contain a small number of turns, and are separated by a special zigzag spacing turn, the coil being in the form of a disc of diameter up to 5 in., and thickness up to 1 in. (Fig. 7). A section of a lattice winding is given in Fig. 8.

The method of winding by hand is simple: A "former" is used, which consists of a wooden cylinder, say 1 1/2 in. in diameter and 2 in. long, in which are driven two radial rows of pins, say twelve in a row, the pins being "staggered" in the rows, and the rows separated by a distance depending upon the thickness of the coil to be wound (Fig. 9). Suitable pins for the purpose may be made by cutting No. 16 or 18 galvanized iron wire into lengths, or one can use slender wire nails, or the pins which joiners call "sprigs." The method of winding is to commence by putting on a zigzag turn round the outside of the pins, as shown in the plan in Fig. 10 (a). On the completion of this turn the wire is wound on in a single layer across the former (Fig. 10 (b)), then another zigzag turn is put on, to be followed by another layer, and so on alternately until the required number of turns has been wound on. The coil is then well soaked in melted paraffin wax, taken out and drained as completely as possible, allowed to cool, and removed from the former by extracting the pins (with a pair of pliers) and pulling out the first zigzag turn, after which it will come away easily.

It will be found quite a simple matter to  
(Continued on page 306)

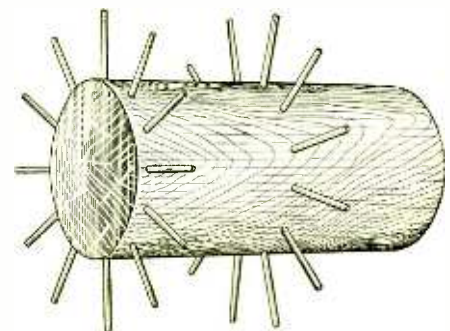

Fig. 9. A Former for Winding Lattice Coils, Made of Wood with Pins Placed in Holes Along Its Periphery.

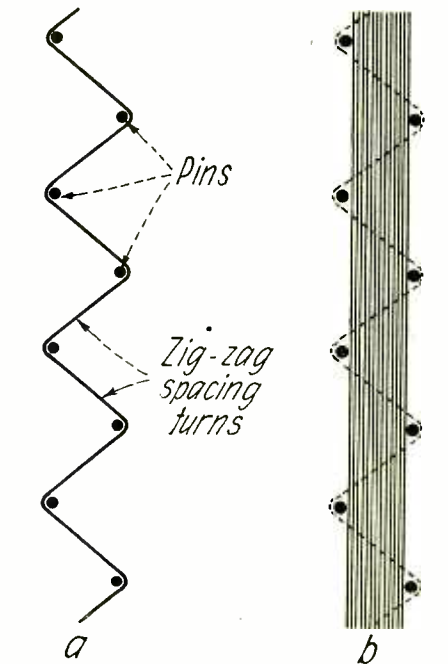

Fig. 10. Illustrating the Method of Winding Lattice Coils. A Zig-Zag Turn Spaces Each Successive Layer.

poses. The following formula will be found to give quite a good approximation:

$$L = \frac{\pi^2 D^2 N^2 P^2 k}{1,000}$$

(microhenries)

- Where D = diameter of coil in centimeters.
- l = length of coil in centimeters.
- N = number of turns per centimeter in any one of the layers.
- P = number of layers or "piles" in the coil.
- k = a constant whose value depends upon the ratio of the length of the coil to its diameter. Various values of k are given in the table below.

| l/D  | k    |
|------|------|
| 0.50 | 0.51 |
| 0.75 | 0.62 |
| 1.00 | 0.67 |
| 1.50 | 0.76 |
| 2.00 | 0.81 |
| 2.50 | 0.84 |

# Continuous Wave and Radiophone Transmitters

By L. R. FELDER

## Part I

**I**N this series of articles it is proposed to take up in a simple but thorough way the subject of C.W. oscillators and radiophone transmitters, giving the theory and practical applications, especially with respect to the actual design of sets of different powers suitable for amateur use. In this first article the theory will be given and the principle of the generation of C.W. oscillations by vacuum tubes will be explained. The various types of circuits which may be used will be gone into, and it will be shown how a very simple, low power C.W. transmitter may be made of a regenerative circuit.

In the past, amateurs have used as transmitters the simple spark gap or some more or less advanced modification of the spark gap. Some of them still use this form of transmitter. It is becoming obsolete, however, due to the fact that it has a number of disadvantages. It creates a lot of interference and does not carry as far as the C.W. transmitter. The C.W. transmitter generates currents which have uniform and equal amplitudes, while the spark transmitter generates currents which have a decreasing amplitude (Fig. 1). Thus it is seen that the energy in the C.W. wave for the same power input must be greater than for the spark wave, hence the efficiency is greater. For these reasons the spark sets, though they have given good service until recently, must make way for the C.W. sets. For the generation of continuous waves a number of different devices can be employed. There is

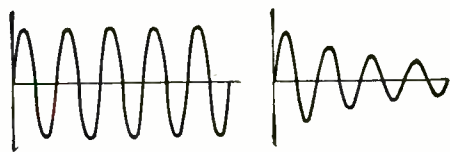

Fig. 1

Left: Oscillations Produced by a C.W. Transmitter. Right: Oscillations from a Spark Transmitter.

first the arc. This is used essentially in commercial, medium and high power stations, though some low power stations are also equipped with arcs. For amateurs the arc is really out of the question, first because it is quite difficult to build a good operating arc, secondly it would be somewhat expensive, and thirdly the arc has the great disadvantage that it cannot generate efficiently the low waves which the amateurs use. Then there is the alternator which is used so extensively on trans-Atlantic work. This is likewise out of the question for the amateur because a good alternator must be bought and is entirely too expensive. There is finally the vacuum tube. This, for the amateur, is an ideal generator. The cost is within his means, its operation is silent, it is made in a number of sizes or powers and he can therefore find one which just suits his purpose, and it operates very well on the waves which he uses.

### THE FEEDBACK SYSTEM

The radio fan who is contemplating building a vacuum tube C.W. oscillator is already acquainted with the vacuum tube as a detector and amplifier. Let us, therefore, go straight to the heart of our subject and see how and why a vacuum tube can generate C.W. oscillations. Its ability to generate oscillations is based directly on its ability to amplify. Every amplifier is capable of acting as a generator if properly arranged in a

circuit. To understand more readily this basic principle let us take an illustration which will be familiar to practically all the readers. When the telephone receiver is placed up against the telephone mouthpiece or microphone we hear a very loud, piercing noise. Almost everybody has tried this

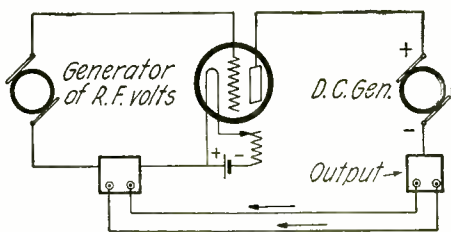

Fig. 2

Arrangement for Feeding Some of the Amplified Output Back to the Grid Input Circuit.

stunt. What is happening here is that the microphone and telephone receiver, which is an amplifying system, generate audio frequency oscillations when properly located with respect to each other. The ordinary room noises which get into the microphone are amplified and passed through the telephone receivers. The amplified sound produced by the vibration of the receiver diaphragm then acts on the microphone, since it is placed up against it, and this is again amplified, and so on. This cycle of occurrences takes place until the sound builds up to the limits of the capacity of the microphone telephone system. In other words, by properly placing the amplifying system of microphone and telephone receivers we have been able to build up audio frequency oscillations. This system constitutes an audio frequency oscillator.

In a similar manner the vacuum tube amplifier if properly connected in an electrical circuit will generate radio frequency oscillations. Suppose we have a vacuum tube amplifier connected in a circuit such as Fig. 2, and suppose we impress a radio frequency voltage on the grid of the tube. This input is of a certain power, P. Now since the tube is an amplifier it follows that we have more power in the plate circuit than in the grid circuit, the amount depending upon how much the tube amplifies. Let us say that the tube amplifies five times; then we have five times as much power in the output circuit as in the input circuit. Since we have more power now than when we started we can take some of this power, say one-fifth, in the output circuit, and bring it back to the grid or input circuit, and still leave four-fifths of the total output power in the output circuit. But when we bring part of this output back into the grid circuit it is again

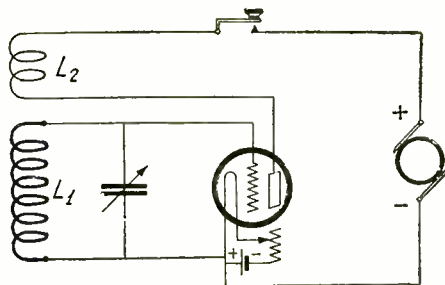

Fig. 3

A Simple C.W. Transmitter Circuit, Similar to a Regenerative Receiving Circuit. L-2 is a Tickler Coil.

amplified and we have more power in the output circuit. In other words, due to the fact that the tube amplifies, we can always take some of this extra amplified power and use it in the input circuit to be re-amplified, and by continually bringing back to the grid some of the amplified output we keep the circuit constantly oscillating. Once we have enough oscillating power in the plate circuit to feed back into the grid circuit the system keeps up oscillating. It will now be clear why any amplifying system may be an oscillating system, for more power comes out of the system than is put into it, and part of this increased output is used as the input to keep this cycle up. The amateur should not imagine that this is a perpetual motion system. Actually the amplification of the radio oscillations is due to the fact that the plate battery supplies the necessary power to amplify the small, feeble oscillations which are impressed on the grid.

### HOW OSCILLATIONS START

It will be evident now to the reader that oscillations may be generated if first some radio frequency oscillations are applied to the grid of the tube, as in Fig. 2. But the question may arise in his mind as to how oscillations are generated when there are no

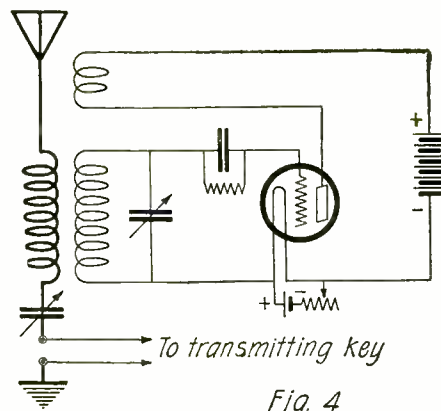

Fig. 4

Showing How a Regenerative Receiver Can Be Used as a Transmitter for Short Distances.

oscillations first applied to the grid of the tube, as is the case with standard C.W. oscillators. The switch is closed and oscillations are produced. The same thing happens here as in the case of the microphone and telephone receiver. Any disturbance in the grid circuit will be amplified in the plate circuit, part of this amplified energy is fed back into the grid and re-amplified and so on, thus producing oscillations. But how is the original disturbance in the grid produced? Simply by the closing of the plate circuit switch. In Fig. 3 we have the regular tube circuit and the two coils L<sub>1</sub> and L<sub>2</sub>, by means of which some of the energy of the plate circuit is induced back into the grid circuit. Now when the filament is burning it emits electrons, but none of them flow to the plate when there is no voltage applied to the plate. At the instant the plate switch is closed a current flows between the plate and filament. The current in coil L<sub>2</sub> has therefore changed from zero to the value of the plate current. This change of current induces a voltage in the grid coil L<sub>1</sub> which is immediately applied to the grid of the tube. We have here our initial grid disturbance. This small grid voltage is amplified by the tube, part of this amplified energy is fed back into the grid, re-amplified and so on, thus generating oscillations. The tube



is thus seen to be a generator of C.W. oscillations by virtue of the fact that it is an amplifier and that the plate and grid circuits are so coupled that energy from the plate is fed back into the grid. Any amplifying system is capable of generating oscillations if the output and input circuits are suitably coupled to each other. This is the basic principle on which the vacuum tube oscillator depends. When the plate and grid circuits are coupled to each other and oscillations are produced, these do not build up indefinitely, for a tube has a certain inherent limitation which holds the maximum amplitude down to definite values depending upon the structure of the elements. Thus the power of the generated oscillations is a certain finite value.

The details of the principle of the production of C.W. oscillations by a vacuum tube are here given in detail because they are not very well known by amateurs. Once the basic underlying theory is really understood the practical applications become a little easier.

**REGENERATIVE RECEIVERS AS C. W. OSCILLATORS**

We thus see that by properly coupling the plate or output circuit of a V.T. amplifier to the grid or input circuit oscillations will be generated. Now every vacuum tube is an amplifier, this property is what makes it so important. A vacuum tube detector in a regenerative receiver acts as an amplifier. Consider the simple regenerative receiver of Fig. 4, which uses the popular tickler circuit. The tickler coil T serves to transfer some of the amplified plate energy back into the grid circuit. This is then re-amplified, producing more plate energy. It is by this means that the regenerative receiver is superior to other types. If the tickler coupling is made tight enough—in other words, if enough of the amplified plate energy is fed back into the grid—the circuit will maintain oscillations even though no signals are received according to the principle outlined above. In fact, this is actually done in receivers which receive C.W. by the heterodyne method. Oscillations are generated in the receiver by coupling tightly the tickler coil to the grid circuit, and these oscillations combine with the received C.W. signals to form a beat note. It will be apparent that instead of using these oscillations to heterodyne received C.W. signals they may be used to transmit, for, since we have produced in the plate circuit a steady flow of continuous oscillations, only a part of which is fed back into the grid circuit to keep the circuits oscillating, the balance of the plate energy may be used by coupling simultaneously to the antenna and radiating the oscillations. In this case the amplified plate energy is used as follows: A small part is fed back into the grid circuit which keeps the circuits oscillating continuously and the balance is induced in the antenna circuit and radiated or transmitted. Thus a regenerative receiver

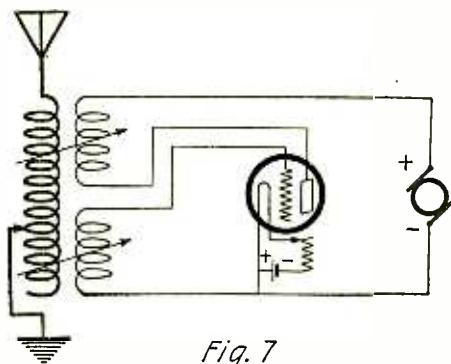

**Fig. 7**  
The Meissner Series Circuit. The Direct Current Plate Supply Is Connected in Series with the Plate Coil. The Plate and Grid Circuits Are Coupled to the Antenna Circuit Through Separate Coils.

may be used as a small C.W. transmitter. By inserting a key in the antenna circuit signals may be sent which would be received at other nearby stations. The actual power of such a receiving set employed as a transmitter is, of course, very low, since a receiving tube is not specifically designed for transmitting. However, for beginners such a set will afford some simple practice in sending with the key and in operating a transmitter. Any type of regenerative set will act as a transmitter by simply putting a key in the antenna circuit.

**STANDARD TRANSMITTING CIRCUITS**

When special circuits are constructed for transmitters it will be found that there are a certain few that are very widely used. These go by various names, but we will consider here only those which are the most important and which the amateur will probably use.

1. *Shunt Circuit.* Various forms of this circuit are used, but they are all essentially the same. In this type the radio frequency circuit and the direct current power supply are connected in shunt across the tube as seen in Fig. 4. Fig. 5 illustrates the case where two separate coils are used for antenna and grid. It is seen that the plate coil is part of the antenna coil and that the grid coil is coupled to it. Where a separate plate coil is used which is coupled to the grid and antenna the circuit is called a Meissner circuit. Here the energy is fed back into the grid by coupling directly to the plate coil, whereas in Fig. 4 the grid is coupled to the antenna coil. In Fig. 5 the plate and antenna are conductively coupled. A modification of this circuit which is most widely used and

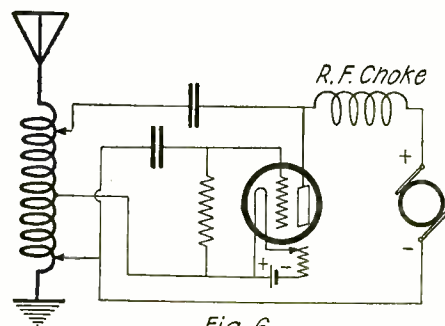

**Fig. 6**  
A Shunt Oscillating Circuit of the Conductively Coupled Type, the Antenna and Grid Circuits Being Coupled to Each Other Through the Same Coil.

which is recommended is the straight conductively coupled type shown in Fig. 6. Here only one coil is used. The plate, grid and antenna are all conductively coupled to each other through the one coil, and adjustments are made by tapping the coil. This circuit is one of the simplest, most efficient and best operating.

2. *Series Circuit.* In this circuit, one form of which is shown in Fig. 7, the direct current plate supply is connected in series with the plate coil. The operation of this circuit is essentially the same as that of the shunt, except that it does not require the use of a radio frequency choke coil. It also has the same different modifications the shunt circuit has, and there is very little difference between the two modes of connecting the D.C. supply. Details of the circuit will be gone into in succeeding articles when the actual design is considered.

For the plate power supply straight A.C. or D.C. may be used. If alternating current supply is used on the plate the oscillator tube will be active only one-half the time, since the plate voltage will be negative half of each cycle when no current flows. Furthermore, when alternating current is used the oscillations generated will have super-

imposed on them the frequency of the alternating current supply. Thus if 60 cycles is used the R.F. oscillations generated will have a 60 cycle note superimposed which will be heard in the receiver. It is, therefore, gen-

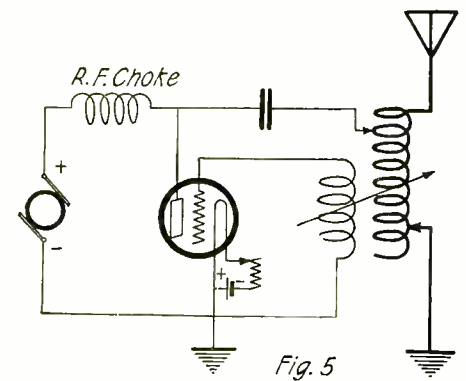

**Fig. 5**  
A Shunt Oscillating Circuit Wherein Separate Coils Are Used for the Antenna and the Grid Circuits.

erally not desirable to use straight A.C. Where D.C. is used the oscillations are pure. In the event that D.C. power is not available it is often necessary to use A.C. power, in which case a rectifier should be used to furnish D.C. to the plate. For the higher power tubes it is necessary to use 500 volts or more on the plate, and many amateurs have not D.C. generators which will yield this voltage. In such cases it is more economical and easier in fact to rectify A.C. and obtain any desired voltage, since a transformer can be made to step up to 2,000 volts as easily as to 500 volts.

For filament power supply it is desirable to use alternating current. If only direct current is available this is satisfactory. Where A.C. is available it should be used by stepping down the 110 volts to the proper voltage. Most recent data show that the use of alternating currents on filaments results in much longer life of tubes than the use of direct current. Since tubes are an expensive proposition it is recommended that alternating current be used wherever possible.

This covers the theory of the C.W. vacuum tube oscillator and the general points involved in all such transmitters. In the next article we will go straight to the practical application of the theory and take up the subject of the design of low power C.W. transmitters up to about 5-watt power.

**WWV TRANSMITS MORE STANDARD WAVES**

In an effort to permit radio operators and fans to check their wave-meters and instruments on standard waves, the Bureau of Standards will transmit standard wavelengths commencing at 10:55 P. M. each night, on August 15, September 13 and 28 and on October 7.

On the last date, WWV will enable amateurs to calibrate their receiving and transmitting sets, since the band covered will be from 222 to 150 meters, the signals being sent between 1:50 A. M. and 3:41 A. M.

The schedule follows: (Keep it for future reference)

| Date     | Frequency K/c | Wave-length meters |
|----------|---------------|--------------------|
| Aug. 15  | 425-1500      | 705-200            |
| Sept. 13 | 425-1500      | 705-200            |
| Sept. 28 | 500-1700      | 600-176            |
| Oct. 7   | 1350-2000     | 222-150 (Amateurs) |

In continuation of the established practice, the Bureau will transmit the call signals "WWV" both in radio telegraph and telephone, each wave-length occupying about nine minutes of time.

# Selection Of Vacuum Tubes

SINCE most vacuum tubes are designed for a particular function, it is of great importance to select those best suited to your requirements. For instance, an amplifying tube, in the usual case, will not function well as a detector, while a tube designed for detection will prove very unsatisfactory if employed as an amplifier. The layman is often at a loss as to the type of vacuum tube to purchase for a definite use. For his benefit, we have printed herewith, a table, including the characteristics of all well-known makes of three-element vacuum tubes, giving as well their operating conditions when used as detectors, radio frequency amplifiers, audio frequency amplifiers or oscillators. If a tube is not suitable for any of these functions, the corresponding space

"B" battery voltage. A grid battery of from four to six volts is satisfactory if the WD-11, WD-12, UV-199, C-299 and "N" tubes are used with "B" batteries of from 60 to 100 volts. An additional six-volt grid battery should be added for every 100-volt "B" battery; this, of course, being proportionate to the increase in the "B" voltage. The Western Electric VT-1, VT-2 and 216-A require approximately a 9 to 12-volt grid potential for every 100-volt "B" battery.

The first important consideration when selecting vacuum tubes is, whether storage batteries or dry cells are to be used for lighting the filaments. All of the 6-volt tubes require a storage battery. The small 1½-volt and 3-volt tubes, such as the WD-11, UV-199 and "N" tubes, can be run from ordinary dry cells. Although both types of tubes work equally well as detectors, the dry-cell tubes are not as satisfactory for audio frequency amplifiers, as they cannot handle as much energy as the larger tubes. However, they make excellent radio frequency amplifiers. The UV-199 and "N" tubes are probably the best that can be ob-

tained for this purpose because of the small size of the elements. For power amplification, where great volume is desired, tubes with large elements, such as the UV-201-A and Western Electric VT-2 or 216-A, are the most satisfactory.

Genuine French tubes and the R.A.C.-3 tubes are satisfactory for all-around work. They are both very good as detectors and radio frequency amplifiers, fair as audio frequency amplifiers and as oscillators. As power amplifiers, of course, they are not well adapted, due to the small size of their elements.

An important factor in the operation of vacuum tubes is the filament voltage. For best results the voltage impressed upon the filament should always be equal to the voltage rating given for the particular



UV-199, C-299.



VT-1 or "J" Tube



WD-11 Tube

| Type                | "A" Filament Volts | Filament Current | Filament Watts Consumed | "B" Plate Voltage |            | "C" Negative Grid Voltage For Amp. | Detector | Radio Frequency Amplifier | Audio Frequency Amplifier | Power Amplifier | Oscillator |
|---------------------|--------------------|------------------|-------------------------|-------------------|------------|------------------------------------|----------|---------------------------|---------------------------|-----------------|------------|
|                     |                    |                  |                         | Det.              | App.       |                                    |          |                           |                           |                 |            |
| UV 199              | 3.0                | 0.06             | 0.18                    | 45                | 60 to 90   | 1 to 4.5                           | Good     | Good                      | Good                      | Fair            | .....      |
| UV 200<br>C 300     | 5.0                | 1.00             | 5.0                     | 22½               | .....      | .....                              | Good     | .....                     | .....                     | .....           | .....      |
| UV 201-A<br>C 301-A | 5.0                | 0.25             | 1.0                     | 45                | 60 to 100  | 3 to 6                             | Good     | Good                      | Good                      | Good            | Good       |
| UV 202<br>C 302     | 8.0                | 2.35             | 18.8                    | 40 to 60          | 100 to 500 | 3 to 9                             | Fair     | .....                     | Good                      | Good            | Good       |
| WE "N" tube         | 1.1                | 0.25             | 0.27                    | 22½               | 45         | 1 to 2                             | Good     | Good                      | Fair                      | .....           | Good       |
| WD-11<br>WD-12      | 1.5                | 0.25             | 0.37                    | 22½               | 45 to 60   | 1 to 3                             | Good     | Good                      | Fair                      | .....           | Good       |
| VT 1                | 2.5                | 0.9              | 0.36                    | 22½               | 45 to 90   | 1 to 3                             | Good     | .....                     | Good                      | Fair            | Good       |
| VT 2                | 7.0                | 1.35             | 9.45                    | 45                | 45 to 350  | 1 to 40                            | Good     | .....                     | Good                      | Good            | Good       |
| 216-A               | 6.0                | 1.35             | 8.1                     | 45                | 45 to 150  | 1 to 12                            | Good     | .....                     | Good                      | Good            | Good       |
| RAC-3               | 4.0                | 0.8              | 3.2                     | 22½               | 40 to 90   | 1 to 10                            | Good     | Good                      | Good                      | .....           | Good       |
| French tube         | 4.0                | 0.8              | 3.2                     | 45                | 40 to 300  | 1 to 25                            | Good     | Good                      | Good                      | Fair            | Good       |



"N" Tube

is left blank. The rest of the chart tells its own story, except perhaps the list of negative grid potentials. A negative grid voltage is necessary only when a tube is used as an amplifier, with rather a high

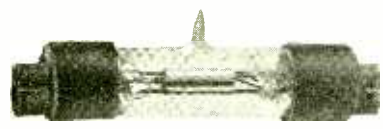

RAC-3 Tube

tube being used. For an example, a pressure of five volts should be maintained on the filament of a Radiotron UV-200 tube, since five is the voltage rating as given on the chart.



UV-200, C-300

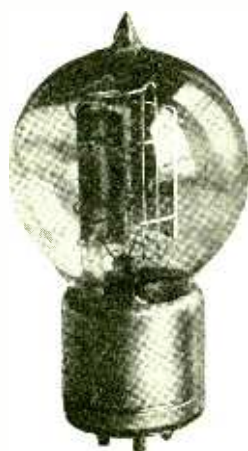

Western Electric VT2



French Tube



Western Electric 216-A



UV-202, C-300

# Facts About DX Crystal Reception

By CARL DREHER

At various times owners of crystal receivers have reported reception of signals from broadcasting stations over distances of several hundred miles; in at least one instance the distance was over one thousand miles. On the face of it a feat of reception on this scale is not impossible. In the pre-tube days of radio it was not unusual for amateur and commercial stations to cover several thousand miles with a sensitive crystal, and what

effect, if any, a regenerative receiver might have on a nearby crystal set in the line of extending the range of the latter.

Two antennae were erected as shown in Fig. 1. One was an outdoor antenna of about the usual dimensions for broadcast reception, while the other ran indoors. The indoor antenna DE was a single horizontal wire on the top floor of a six-story apartment house, and it was so arranged that a receiving set might be connected at either end. The outdoor antenna ABC ran from a point C indoors on the same level as DE, to the roof at B, and thence horizontally about 6 feet above the roof in a northwest direction. The indoor antenna was oriented northeast, the two flat tops being at sensibly right angles. The coupling between these two antennae was no closer, it will be observed, than the value frequently encountered in practice between aerials on the same or adjacent roofs.

The first experiments were made with a single tube regenerative set connected to the outdoor antenna, and a crystal set connected to the indoor antenna, both sets being of the single circuit type. The position of the two sets is shown in Fig. 2. The sets in this case were in the same room and connected to a common ground. Tests were first made on a local 500-watt station, WJZ, wave-length 455 meters, distant about five miles. The procedure and results are given below.

triple its own signal when the outdoor antenna was tuned to the same wave-length.

3. Both sets being left tuned as before, with minimum tickler coupling on the regenerative set, the tube of the latter was lighted. No effect was observed on the crystal signal.

4. With the operator listening on the crystal set, the tickler coupling of the tube set was brought up to regenerative level, but short of oscillation. By this means the crystal signal was increased about 900 per cent (tenfold). The final crystal signal was therefore some 30 times what it had been without the assistance of the regenerative set

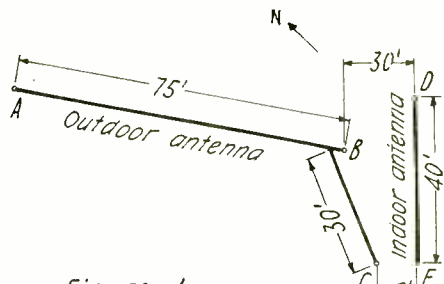

Figure 1

The Dimensions and Approximate Directions of the Two Aerials Used by Mr. Dreher in His Tests.

was at that time rated as a 2 K.W. transmitter, referring to transformer input power. The motor generator of such a transmitter normally consumed 30 amperes at 120 volts D.C., or 3.6 K.W. The motor generator of a modern 500 watt broadcast transmitter, running on D.C., is rated at about 6 H.P., or 4.5 K.W. at the motor end. While the distribution of energy in a C.W. telephone transmitter and a spark transmitter is considerably different, the former, for example, employing energy to heat filaments which is not directly involved in the conversion of audio frequency into radio frequency energy, it is clear from these figures that the radiation outputs of the two types of sets are of about the same order, and that what was frequently accomplished with crystal receivers 10 or 15 years ago, in picking up distant spark telegraph signals, should still be feasible in telephone reception today.

In one respect, however, receiving conditions have undergone a great change. Where formerly, in urban centers, there were only a few receivers to the square mile, now there may be hundreds or even thousands. It has been suggested, accordingly, that "reradiation" from the more sensitive tube receivers, especially when in a state of oscillation, might account for some of the receiving records made with elementary types of sets normally rated as good for only 10 or 20 miles. Other experimenters have denied the possibility of this, on the ground that signals so received would be distorted, while actually no distortion was apparent in at least some of the crystal DX reception reported. The writer accordingly set about making a series of tests to determine what

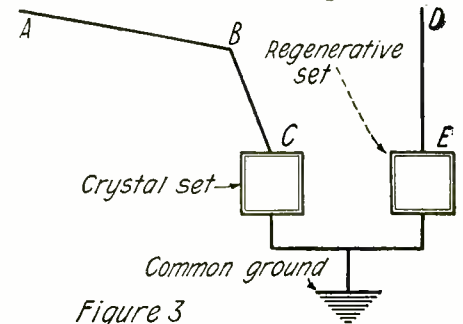

Figure 3

With the Crystal Set Connected to the Outdoor Aerial, the Effect of the Regenerative Set Upon it Was Less Apparent Than in the Arrangement of Fig. 2.

and outdoor antenna. Grounding the outdoor aerial immediately cut the crystal signal to its original value. The amplified crystal signal was not distorted, inasmuch as regeneration on the tube set was not carried to the heterodyne point. Although the tube set had been tuned by listening on the crystal only, it was found to be as accurately tuned to WJZ as if its own telephones had been used in the normal manner.

5. Listening on the regenerative set, it was observed that tuning and detuning the crystal set altered the regenerative set signal just appreciably. When the crystal set was tuned to 455 meters the tube set signal was diminished very slightly—enough to be noticeable when one was looking for it. That is, the crystal set was able to get an amplification of about 30 times with only a slight diminution in the regenerative signal, an effect due to the inherent nature of regenerative R.F. amplification. The energy withdrawn by the crystal set is easily compensated for by increased regeneration, and the additional load imposed by the crystal set allows a higher value of regenerative amplification short of the squealing point than would otherwise be possible. In fact, with the tube set adjusted to maximum clear signal on WJZ, the crystal set being tuned to the same wave-length, when the crystal set was detuned the regenerative set broke over into oscillation.

The tuned regenerative signal was about 120 times that of the unassisted crystal signal. (Continued on page 292)

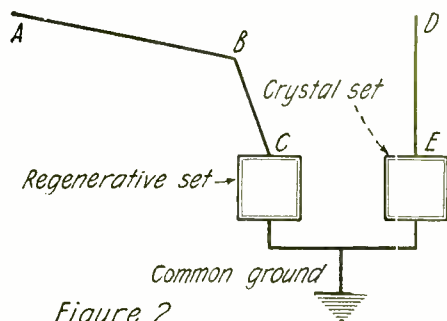

Figure 2

With the Sets in the Same Room and Connected to a Common Ground. There was a 900 Per Cent. Increase in Signal Strength from the Crystal Set When the Regenerative Set Was Brought Close to the Point of Oscillation.

**A RADIO MAGAZINE**

Do you know that SCIENCE AND INVENTION carries the largest radio section of any scientific magazine published? Radio articles of particular interest for the fan and layman. In other words

**SIMPLIFIED RADIO**

**RADIO ARTICLES APPEARING IN THE SEPTEMBER 1923 ISSUE OF SCIENCE AND INVENTION.**

RADIO FOR THE BEGINNER—HOW AMPLIFIERS WORK.  
By Armstrong Perry

PHOTOS AND CALL LETTERS OF RADIOPHONE BROADCAST STATIONS

BALLOONS TO SUPPORT RADIO ANTENNAE.  
A ONE TUBE REGENERATIVE RECEIVER.  
By Bert T. Bonaventure.

NEW VACUUM TUBE WITH NINE LIVES.

RADIO QUESTION AND ANSWER BOX.

COLONEL HEEZALIAR FLIRTS WITH RADIO.

NEW DEVELOPMENTS IN WIRED WIRELESS.

DETECTOR AND TWO-STEP RECEIVER WITH NOVEL TUNER.  
By E. A. Price.

NEW RADIO CONTROLLED TORPEDO.  
By Graser Schornstheimer.

1. With the regenerative set inactive and the outdoor aerial grounded, a moderate signal was received on the crystal set and indoor aerial. This was the normal pick-up of this combination, unassisted.

2. The outdoor aerial was ungrounded, and, with the tube cold, the regenerative set was tuned, the operator listening on the crystal set. When the regenerative set was tuned to 455 meters the crystal signal on WJZ increased about 200 per cent, or three-fold. The setting of the crystal set was not changed during this test. In other words, the crystal set on the small antenna, by virtue of its electrostatic coupling to the large antenna picking up a stronger signal with higher received antenna current, was able to

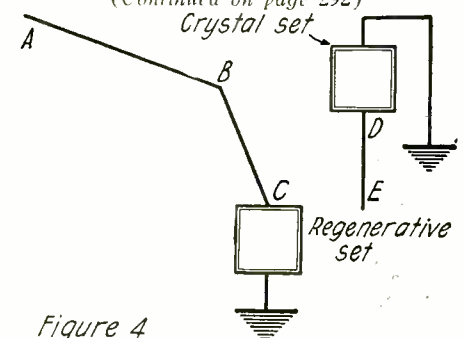

Figure 4

With the Sets Separated and Using Individual Ground Connections, the Results Were But Slightly Altered.



**T**HIS Department is open to all readers. It matters not whether subscribers or not. All photos are judged for best arrangement and efficiency of the apparatus, neatness of connections and general appearance. In order to increase the interest in this department, we prefer to publish photographs of stations accompanied by a picture of the owner. We prefer dark photos to light ones. The prize winning pictures must be on prints not smaller than 5 x 7". We cannot reproduce pictures smaller than 3½ x 3½". All pictures must bear name and address written in ink on the back. A letter of not less than 100 words giving full description of the station, aerial equipment, etc., must accompany the pictures.

**PRIZES:** One first monthly prize of \$5.00. All other pictures will be paid for at the rate of \$2.00 each.

## Station 1AKB, Lynn, Mass.

### This Month's Prize Winner



1AKB Is One of the Stations That Was Heard in France During the Trans-Atlantic Tests. The Absence of Helter-Skelter Wiring Is a Point to the Credit of Mr. Cucuvalas, the Owner. Note That the Wiring of the Receiving Units Is From Right to Left. This Allows Short Leads to the Antenna Switch.

**S**INCE the advent of the recent trans-Atlantic tests, I have had any number of inquiries concerning this station. To those interested in the general details of the receiving sets and the transmitter, I am giving a general description.

The antenna of Station 1AKB is of the L type, consisting of five wires, spaced 3' apart; 65' long and with an 18" five-wire lead-in. The lead-in side of the aerial is

supported by a 25-foot mast; the opposite end is supported by a mast on top of the house, about 70' from the sidewalk. The counterpoise system includes 49 wires, 8' from the ground and 33' long. This is situated directly under the main aerial. The leads from both the antenna and counterpoise are connected directly to the oscillation transformer by heavy leads. The station itself is to the rear of the house and

stands about 125' above sea level. Although only 8' square, there is sufficient room for the apparatus. Being sound-proof, there are no disturbances from outside sources that might otherwise cause enough interference to be a detriment to the efficient handling of traffic.

As to the apparatus: Receiving set No. 1, which, in the photograph, is seen below the large card containing the call-letters of this station, is a three-circuit honeycomb regenerative receiver, having a wave-length range of from 125 to 2,000 meters. A detector and two stages of audio frequency amplification are included in the same cabinet. This receiver gives excellent results when working DX stations early in the evening when QRM is at its height; it is sharper than any set ever tried at this station. Receiving set No. 2, directly beneath, is a single-circuit type, with two stages of audio frequency amplification; the detector being included in the receiving cabinet itself. This set is used mostly for the reception of broadcast stations, as it brings in the phones in fine shape. The transmitter shown to the right is a 20-watt C.V. set, using four UV-202 tubes. The hook-up employed is the famous 1 DH and it produces excellent results. The energy for this set is supplied by a G. E. 250-watt motor-generator, which is under the table in a sound-proof housing, which eliminates all noise caused by the motor. With 1100 volts D. C. on the plates of the tubes, a radiation of 3.8 thermocouple amperes is obtained.

There are a few incidentals which may be of interest. To the left of the photograph, you will notice a phonograph, which was built by the owner and is operated especially

## Station 9ZT, Minneapolis, Minn.

**I** AM enclosing a recent picture of Station 9ZT. This station is located at 54 Penn avenue, N., Minneapolis, Minn. It has been in operation since the first of the year, and consistently works all districts, both coasts, and handles a fair amount of traffic. It is operated almost exclusively by the owner, D. C. Wallace.

The antenna system consists of six wires, 50' long on 12' spreaders, supported by two masts 60' and 85' high, respectively.

The counterpoise is radial, similar to the spokes in a wheel, and consists of 25 wires at the height of 8'. Each wire is 100' long, so the entire counterpoise covers a circular area of 200' in diameter.

The radio room is located in a five-room bungalow, which room was planned along with the building of the house. At the time the foundations were laid, a radial ground system was put in, covering almost the entire lot. This ground system has proven of no use whatsoever, but there is a certain

(Continued on page 314)

9ZT Has a 250-Watt That Gives a Kick for Every Watt, Which Is More Than Some Can Say. Together With a Good Receiver, Mr. Wallace Is Able to Handle DX Traffic Regularly.



for giving out a little music for stations he works and all others who wish to listen. This takes place only when the air is silent. The owner has preferred the use of a seven-cell Edison battery for supplying the necessary current for lighting the filaments of the vacuum tubes. This battery has a capacity of 250 ampere hours. Aside from being easier to handle, it also has the advantage of being practically indestructible in cases when it is overcharged.

Station 1AKB has been heard on C.W. from Miami, Fla., north as far as Ontario, Canada; west as far as Missouri, and east across the Atlantic to France. On phone using only two five-watt tubes as oscillators, and with grid modulation, this station has been heard with both voice and music, in Indiana, Tennessee, Washington, D. C., New York, Maryland, New Hampshire, Connecticut, Rhode Island, Pennsylvania, Vermont and Maine.

PETER CUCUVALLAS.

**8DKC**

Jas. A. Wilson announces that his station 8CPY will be closed from April 15 to November 1. A new license has been issued, including the call 8DKC, to operate a 100-watt C.W. and phone station, at his summer home at Gordenach Lake, Mich. Pse QSL as soon as you hear this station. All communications answered. Mail address, Jas. A. Wilson, care of Crescent Engraving Co., Kalamazoo, Mich.

**Meet J. O. Smith—2ZL**

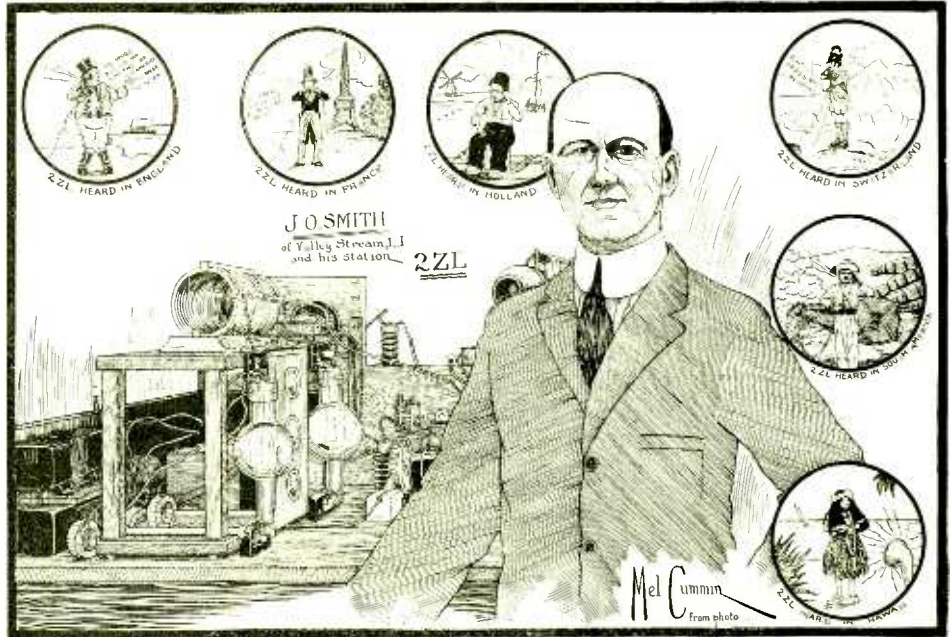

Those of You Who Haven't Heard 2ZL on the Air, at Least Know Who the Owner Is. Mr. J. O. Smith Has Done More Than His Share in Making Amateur Radio What It Is Today. He Is One of Our Grand and Glorious DXers. This Sketch Gives a Good Idea of What a Fine Transmitter He Has.

**Radio to Play Important Part in Polar Expedition**

Dr. Donald B. MacMillan, D.Sc., F.R.G.S., who was formerly a professor at Bowdoin College and was first induced to go to the Arctic by Peary and incidentally accompanied Peary on the expedition on which Peary reached the Pole and has been back to the Arctic seven times since, was the guest of honor at a dinner given at the Hotel Sherman, Chicago, March 21st, by U. J. ("Sport") Herrmann, who incidentally is the owner of the Chicago Radio Show, one of the owners of the Boston Red Sox, and a well known Chicago yachtsman. This dinner was a private affair, attended by prominent naval officers and city officials.

During his talk Dr. MacMillan told of the hardships of the Arctic. He said that the greatest hardship is not, as is commonly supposed, the intense cold—which sends the mercury sometimes as low as 60° below zero—that it is not the privations (for on one expedition which Captain MacMillan commanded, he demonstrated that he and his crew could live for a year on nothing but the food which sustains the Eskimo)—but that the greatest hardship is the awful solitude—everything going out and nothing coming in. Mr. U. J. Herrmann, who from the start has been intensely interested in radio, inquired why he, MacMillan, did not take along a radio set. Dr. MacMillan replied that it would take up too much space. There developed a considerable discussion of just what radio would do, in which discussion Dr. MacMillan became greatly interested. As an outcome, he arranged to install both sending and receiving sets aboard his ship, the *Bowdoin*, and converted the entire forward end of the forecabin into a radio room.

**WHAT THE EQUIPMENT CONSISTS OF**

MacMillan takes with him, installed in the fore part of the ship, a long distance standard broadcast receiving set with a wave-length range of from 150 to 900 meters, and equipped with a three-stage amplifier and loud speaking apparatus, as well as a long wave receiving set with a maximum wave-length of 20,000

meters. With these two sets reception will be possible of not only amateur telegraph and phone stations and radiophone broadcasting stations, but also naval and commercial trans-oceanic stations from which press reports, time signals, weather forecasts, etc., can be secured.

The transmitting equipment consists of a 500 cycle interrupted-continuous-wave set, using two 250-watt transmitter tubes. This apparatus is mounted very compactly in semi-panel form with all necessary meters, and is supplied with current by two gas engine-driven Delco generator units entirely separate from the regular power plant of the ship.

The ship's antenna is of peculiar construction, due to the fact that the *Bowdoin* depends for part of its motive power on sails and is of comparatively short length. A stem to stern antenna is used, passing over the main mast and foremast, the lead-in dropping through the foredeck to the radio quarters. In order to insure good ground, steel and copper plates have been riveted to the hull and in addition connections have been made to the propeller shaft through the engine and to the supply of coal which is carried partly as ballast and for emergency use.

**ARRANGEMENTS FOR TRANSMITTING MESSAGES FROM AND TO THE ARCTIC**

Dr. MacMillan will take with him as wireless operator Donald H. Mix of Bristol, Conn. Mix was selected by Captain MacMillan from five men who were chosen by Mr. Hiram Percy Maxim, president of the American Radio Relay League.

Not only technical ability as an operator and the ability to withstand hardships were requisites, but in particular the faculty for making oneself congenial among a small crew of men on an ice-bound ship. Dr. MacMillan's crew consists of only seven men. Mix represents Captain MacMillan's choice from among some of the best wireless operators in the country.

Once a week Mix will transmit from the *Bowdoin* a five hundred word story of Arctic adventure and will transmit also dia-

(Continued on page 316)

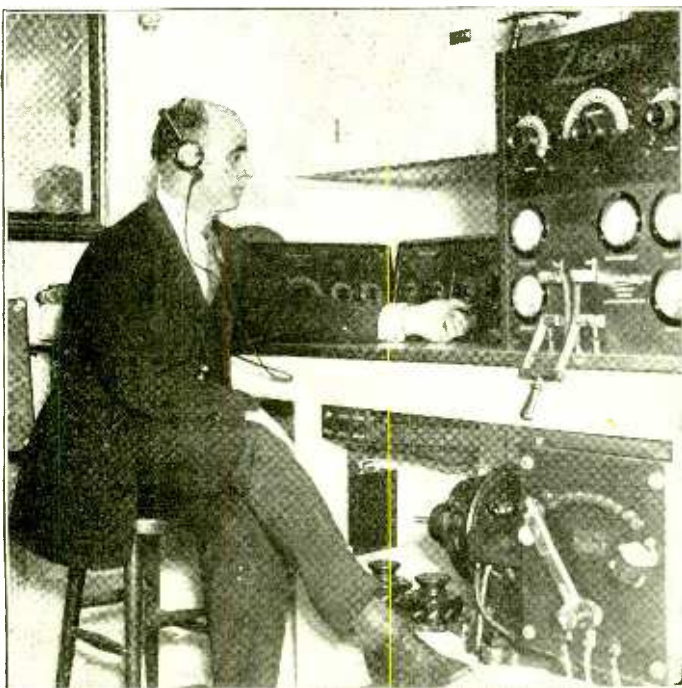

Dr. Donald B. MacMillan Listening In on His Receiving Set Aboard His Ship, the *Bowdoin*, Which Is to Make the Trip to the Arctic Regions. The Radio Equipment He Will Take With Him Is Complete in Every Respect. Donald H. Mix (1TS) Is to Be the Radio Operator.



## The All-Purpose Receiver

A RECEIVING SET AND DETECTOR WHICH CAN BE USED IN A VARIETY OF WAYS AND IS DESIGNED FOR THE ADDITION OF RADIO AND AUDIO FREQUENCY AMPLIFIERS

By M. B. SLEEPER

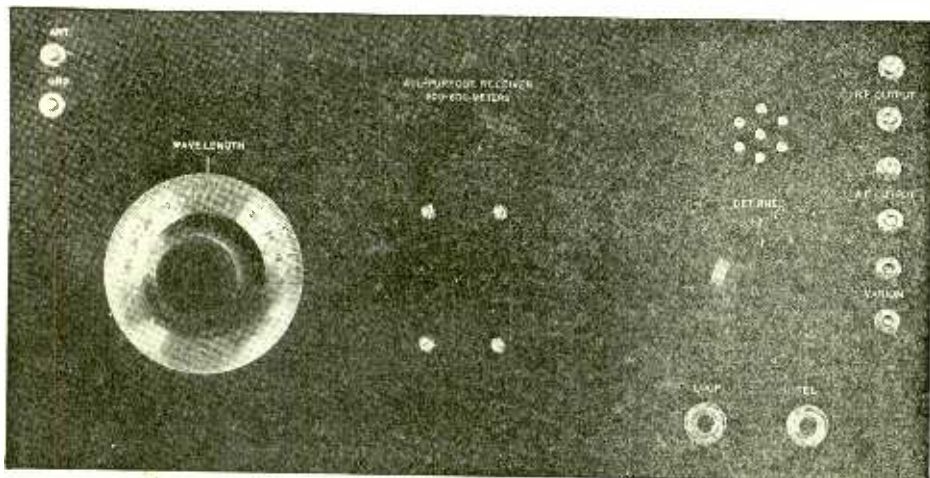

A Front View of the "All-Purpose Receiver." Note That There Is But One Wave-Length Control, This Being a Variable Condenser. This Set Was Constructed from the Plans Given in This Article.

THE idea of simplicity in design has been driven home so strongly to experimenters that the old type of radio set which used to warm our hearts, the outfit oftentimes built on a switch board and built like a switch board, so that no end of various circuits and combinations could be made, has been practically abandoned. In its place has come the single-purpose set, ordinarily a complete unit so designed as to accomplish a specific result with one particular type of circuit.

However, not all of us can afford to build equipment of that sort, a complete set for each different thing we want to do. Therefore, the equipment shown in the accompanying photographs has been developed with the idea of presenting a set which, though very simple indeed in design and operation, can be made to do a great number of different things. So that these will be clear they are listed below:

### A RECEIVING SET FOR 200 TO 600 METERS

1. A non-regenerative receiver operating on an antenna and ground (Fig. 1).
2. A non-regenerative receiver for short distance reception operating on a loop (Fig. 1).
3. A regenerative receiver operating on an antenna and ground (Fig. 2).
4. A regenerative receiver operating on a loop (Fig. 3).
5. Any of the above combinations with audio frequency added (Fig. 1).
6. Any of the first four combinations with radio frequency amplification added (Fig. 1).
7. Any of the first four combinations with both radio and audio frequency amplification.

If you will go over the accompanying photographs and diagrams you will see that this receiving set is made up of a fixed coupler having a non-adjustable primary winding with fixed coupling to the secondary coil. The fixed coupler carries the primary

winding inside the center section, while the secondary, divided into two parts, is held by the radial arms of the frame work. When

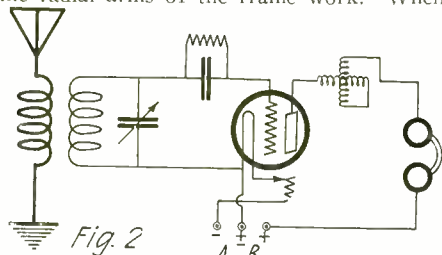

Showing the Connections of the Set When Used With an Aerial and Ground. An External Variometer Is Included, to Obtain Regeneration.

the receiving set is used with the antenna and ground, the loop jack, just below the rheostat control, connects the secondary inductance across the 23-plate variable con-

denser and on to the grid and filament of the detector tube. Inserting the loop plug, however, disconnects the secondary winding and replaces it by the inductance of the loop. In the plate circuit of the detector are binding posts for connection to an amplifier and also to a variometer. If neither amplifier nor variometer is used, those posts should be short circuited so as to close the plate circuit. With the variometer connected, the set, used with an antenna and ground, becomes a conventional 3-circuit regenerative receiver.

### AMPLIFIERS MAY BE ADDED

The audio frequency amplifier will be described in the next issue. Binding posts are also furnished for a radio frequency amplifier. They are connected to the variable condenser, so that the tuning circuit goes directly to the first radio amplifier. This unit will be shown in a coming issue. To simplify the design and to shorten the leads, the radio frequency amplifier contains a detector. Therefore, the detector on the receiving set panel is not used. It is only necessary to disconnect the "A" and "B" battery leads and remove the detector tube. This may seem like a duplication to have a detector also in the radio frequency amplifying unit, but the duplication is limited to a rheostat and socket. When the three units are shown together you will understand the advantages of the arrangement chosen.

The tuning unit is mounted on a formica panel measuring 7" by 14", a standard size available in practically all the radio stores. Moreover, cabinets can be purchased to accommodate panels of that size. Fig. 4 shows the layout at exactly one-third scale. Consequently, if you measure the distances on the drawing and treble them, you can lay out your panel very easily. The drawing is shown in this way because experimenters frequently have difficulty in understanding drawings which are covered by dimensioned

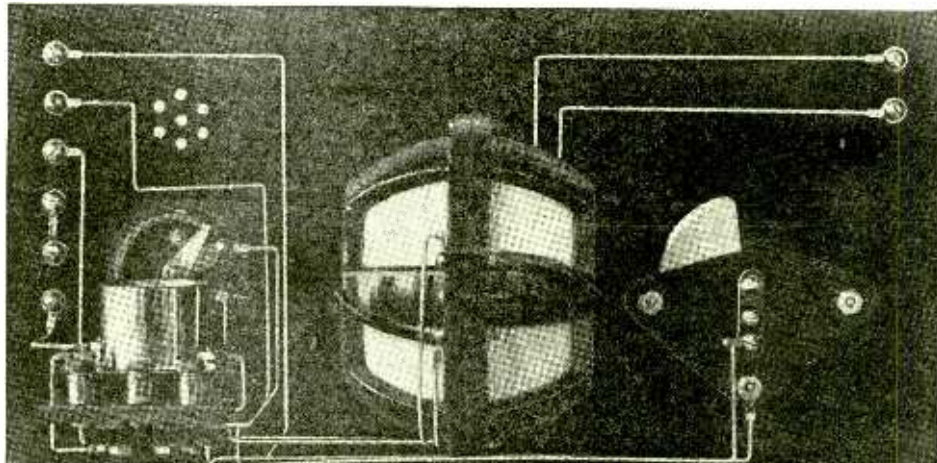

A Rear View of the Same Set, Showing the Tuning Variable Condenser, Fixed Coupler and the Detector Unit. The Fixed Coupler is a Variometer With No Conductive Connection Between the Rotor and Stator, as Shown in the Circuit Diagram of Fig. 1.

lines and figures. With the exception of a few holes otherwise marked, a No. 13 drill is used. So as to get the location of the holes exactly, make sure first that the dimensions of your panel are accurate and that the corners are square and true. Then you can scratch lines with a scribe working against the plate of a combination square to show where the holes go.

**DRILLING THE PANEL**

Be sure to make center punch marks to start your holes, for drills have a habit of working off to one side unless that precaution is taken. A very handy instrument is the Starrett automatic center punch, a small device carrying a spring trip in the handle. A hardened point is located on the panel and the spring compressed by pressing the handle. Then the trip releases and a sharp blow is thus given the point. It is possible to locate the punch marks more accurately by this method than with a plain center punch and hammer.

When you drill the large holes for the jacks you will not be able to use an ordinary hand drill. If you have no press, make a small hole with the hand drill. Then put the 15/32" drill in your vise and press the

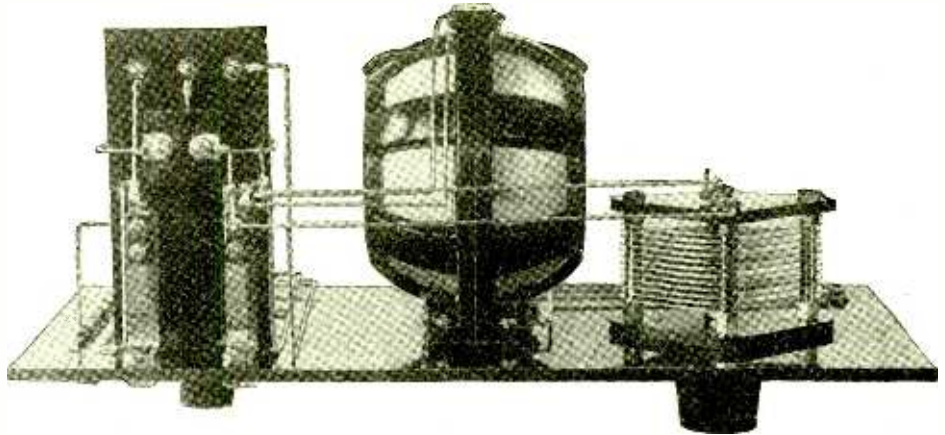

A Bottom View of the "All-Purpose Receiver." This Shows Clearly the Method Employed for Mounting the Base of the Detector Unit. The Two Jacks Form the Support for the Base.

you start to do any assembly work. The set illustrated has engraved names for the various controls. This adds greatly to the appearance of the outfit and is not particularly expensive. If there is no one to do this work for you locally you can send the panel

binding posts on the front and base panels, making sure that the lugs point in the directions shown in the photographs. This is important for it will help you greatly in the wiring. Referring to Fig. 5, make as many connections at this point as possible, using square tinned copper bus bar carefully bent and fitted.

It is very much worth while to take care in making connections for it adds so much to the appearance as well as the successful operation of the set. Use Nokorode soldering paste, but in such small quantities that there is no extra paste to run around on the panel and provide leakage paths. Make sure that your soldering iron is clean and hot enough so that the solder flows freely. Fill each lug with solder, but do not leave extra chunks on the terminals.

The grid condenser can be mounted at this stage of the assembly. It is a Micadon of 0.0005 mfd. Fasten the lugs to the condenser with 3/8" 6-32 R.H. screws and nuts. The simplest way to put on the grid leak is to scratch one clamping plate with a scribe and rub on a soft lead pencil. This

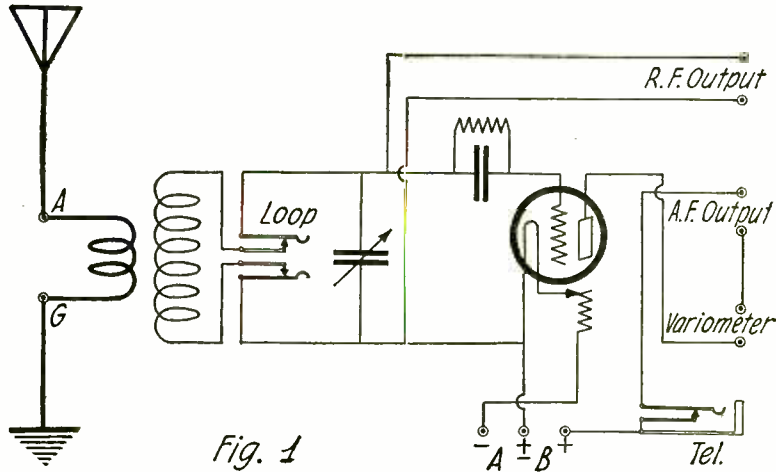

The Wiring Diagram of the "All-Purpose Receiver." By means of binding posts, R.F. or A.F. Amplification Can Be Added Without Disturbing the Internal Wiring.

panel down on the drill, rotating it at the same time. While that is only a makeshift, of course, it is the easiest method. You will notice that over-sized holes are specified for the condenser and rheostat shafts. That is to give sufficient clearance so that the shafts will not bind. Fig. 5 shows the base panel at one-half scale. The four holes for mounting the panel on the jacks are arranged to fit Pacent jacks. If you use any other type make sure that you change the holes accordingly. The four holes marked X should only be drilled if a fixed coupler of the make mentioned further is used. If the coupler is built by the experimenter himself holes marked Y should be drilled.

Drill all the holes in both panels before

away and have the engraving done at quite a reasonable charge. The first assembly work to be done is to mount the jacks. If you are going to put the set in a cabinet you will have to cut off a small part of the jacks at the ends which fit against the panel. With the jacks tightened in place remove one of the screws which clamp the springs and replace it with a 1" 6-32 F.H. screw. Put a nut on the underside to hold the springs. Repeat this process, one screw at a time, until all four have been changed. That will hold your base panel very securely. Then mount the socket, using flat head screws, from the bottom up, so that there will be no interference with connections to the jacks. Mount the

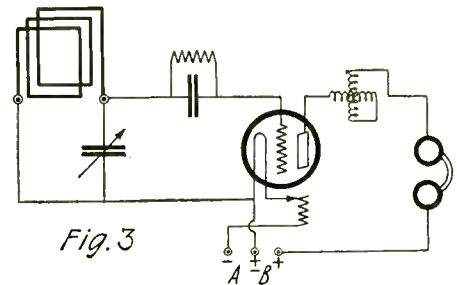

Connections of the Set When Employing a Loop Aerial and an External Variometer for Regeneration.

can be adjusted, when the receiver is in use, to exactly the correct resistance. Be sure that the pencil marks go right up against the condenser terminals so as to make connections with them. A cartridge grid leak may be used with a condenser fitted with clips. Put the rheostat in place, with lugs on the terminals, and put on the connecting wires.

Next mount the fixed coupler. It may be of the new Sleeper radio design, or made of 46 turns of No. 20 D.C.C. wire wound on a 4" tube, with the primary wound with eight turns of the same wire as shown in the sketch. Connections from the secondary winding are at the rear and for the primary winding at the front, next to the panel. Put on the variable condenser and make the remaining connections.

If you are going to use the outfit as a plain non-regenerative set, put jumpers across the binding posts marked A.F. OUTPUT and VARIOM. Connect your antenna and ground to the left-hand binding posts, a 22 1/2-volt "B" battery across the right-hand and center binding posts on the base panel, looking at them from the front of the set, with the plus lead to the right- (Continued on page 339)

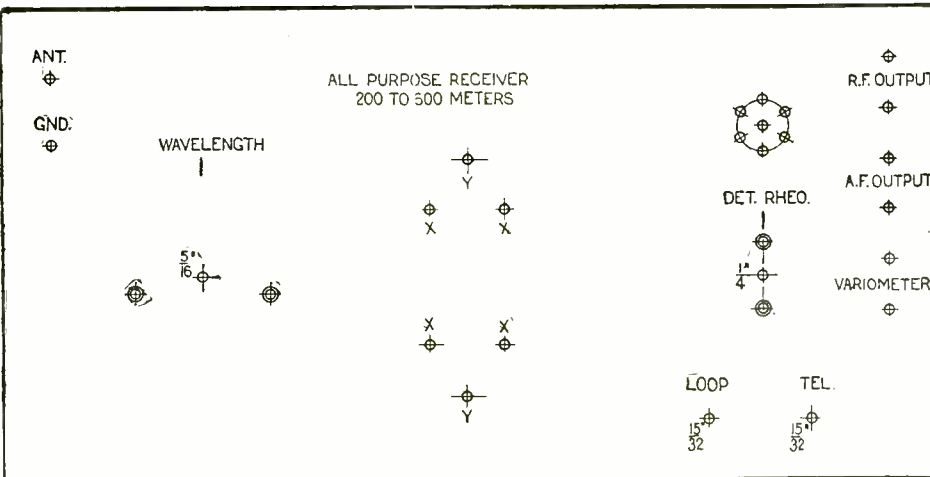

ALL HOLES NO. 16 DRILL, UNLESS OTHERWISE SPECIFIED

Fig. 4

The Panel Layout of the Receiver, the Dimensions Here Being One-Third the scale of the Original.

# The Modified Reinartz Receiver

By MAURICE L. MUHLEMAN

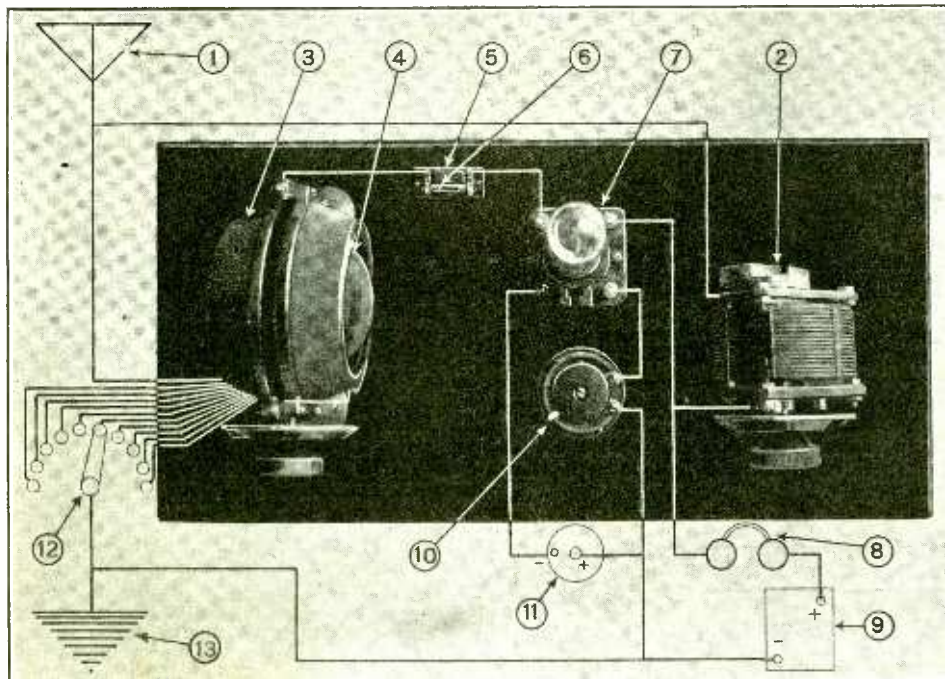

Fig. 1. The Modified Reinartz Receiver Is Very Easily Built, There Being But Few Parts. The Set Above Is Spread Out on a Board so That the Connections Are Shown Clearly. The Constructor should Have No Trouble Here, as the Wiring Is Not Complicated.

THE excellent results that have been obtained from the original Reinartz Receiver have made it one of the most popular sets in use today.

The number of variable units, although not necessarily complicating the control of the set, are not, in the usual case, properly adjusted by the novice. A more practical type for the beginner, and one that includes all of the advantages of the original Reinartz Receiver, is the modified form, developed by him as well.

The control units of this outfit consist of a simplified form of vario-coupler and a 43-plate variable condenser. All of the actual tuning is accomplished by the two adjusting knobs and dials attached to these instruments.

### MAKE-UP DETAILS

Sufficient details are given in this article to enable the prospective builder to proceed without difficulty. The general layout of the receiver is shown in the photograph of Fig. 1. This disposition of apparatus should be followed as closely as possible, especially if the instruments are to be mounted on a panel.

The parts necessary for the construction of the modified Reinartz Receiver are: One variocoupler (3-4); one 43-plate variable condenser (2); one .00025 mfd. grid condenser (5); one 1-megohm grid leak (6); one vacuum-tube detector (7); one standard make filament rheostat (10); one 22½-volt "B" battery (9); one 6-volt 40 to 60 ampere hour storage battery, or a dry cell, depending upon the vacuum tube used (11); and a switch-arm and ten switch-points (12).

A few words are necessary concerning the variocoupler. It is suggested that a variocoupler be purchased, and rewound with No. 26 double cotton-covered wire, putting 30 turns of it on the rotor and 30 turns on the stationary coil. The first 10 turns wound on the stationary coil are tapped and their leads connected in consecutive order to 10 switch points. This provides 10 taps, of one turn each. A standard variocoupler can be used with its original windings; however, the results obtained from the receiver in this case will not parallel the efficiency of a variocoupler rewound in the manner de-

scribed. A standard variocoupler generally has two sets of taps, namely, eight taps of one turn each, and eight taps of eight turns each. If it is imperative to use a standard variocoupler, provide 10 switch-points, as in the original layout, connecting, in consecutive order, the taps of one turn each to the first eight switch points. The next two taps of eight turns each, are connected to the last two switch points. The last six taps on the stationary coil of the variocoupler are short-circuited by connecting them all together, or preferably this excess wire is removed. It will be noted that the variocoupler is connected in the same manner as a variometer; that is, one of the terminals of the rotor is connected directly to the terminal of the stationary coil farthest from the tapped end of the coil.

To reach the higher broadcast wavelengths, a 23-plate variable condenser should be connected from the eighth switch-point to the end of the rotor coil leading to the grid condenser.

The wiring connections of this receiver are clearly shown in the photograph of Fig. 1. For further reference, however, the complete circuit, in schematic form, is given

in Fig. 2. The numbers in Figs. 1 and 2 correspond.

### THE DETECTOR TUBE

Any type of detector tube can be used with this receiver. One dry cell is all that is necessary for filament supply, if a WD-11 tube is employed. A small three-cell flashlight battery will suffice as the filament supply for a UV-199 tube; however, three 1½-volt dry cells, connected in series, are better suited for the purpose. In such case, a 30-ohm rheostat should be used. These are especially marketed for the UV-199 tubes. A 40 to 60 ampere hour storage battery should be used when employing 6-volt detector tubes. The UV-201A tube is an exception, in that a 20 to 30 ohm rheostat is best used for the control of its filament. The other 6-volt tubes require only the usual 6- or 10-ohm rheostat. The UV-199 and UV-201A tubes usually require a 40-volt "B" battery, when utilized as detectors.

### OPERATION

The operation of this receiver is comparatively simple, the wave-length being controlled by the variocoupler and regeneration controlled by the variable condenser. Experiment should first be made on some nearby stations, to determine what positions of the switch-arm prove best for the different standard bands of wave-lengths. Changing the position of the switch-arm tends to loosen or tighten the coupling of the antenna circuit.

When the set is completely wired and ready for operation, light the filament of the vacuum tube, by means of the rheostat. With the switch-arm on the third or fourth switch-point, as a convenient position, proceed to tune by the simultaneous adjustment of the variocoupler and variable condenser dials. Starting from zero, on the variocoupler dial, slowly work towards 180 degrees, adjusting the variable condenser dial for every change in the latter, always, though, keeping below the point where the circuit tends to oscillate. A squealing noise is a fore-warning of such an impending condition. When this is heard, slightly retrace the adjustments until operation is again quiet. Broadcasting stations on different wave-lengths will be heard at various settings of the variocoupler dial. After a desired station has been picked up, slight adjustments of both dials will considerably increase the volume. This last-mentioned operation is rather critical and it is best to use Vernier attachments, or a lead pencil with an eraser on the end; placing this between the periphery of the dial and the panel, turn the pencil with the thumb and forefinger. Best results are obtained just below the point on the dials where squealing is manifested.

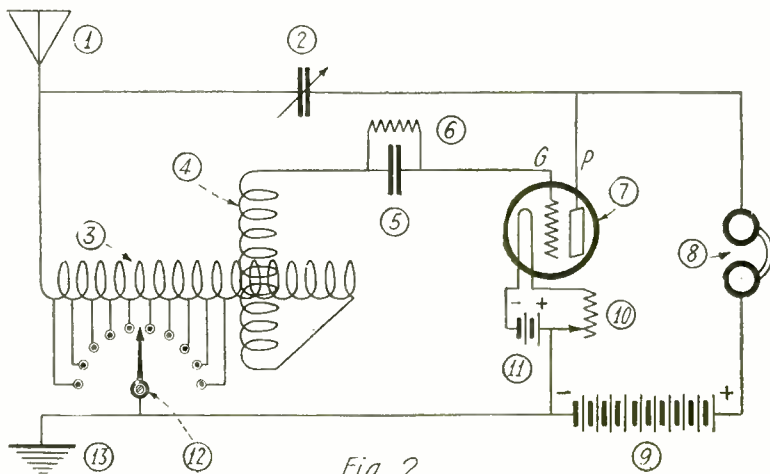

The Circuit Diagram of the Modified Reinartz Receiver. Note that the Variocoupler Is Connected as a Variometer. The numbers here Given Correspond With Those in the Photograph.

Fig. 2



# An Inductance-Variometer—A Utility Radio Unit

By SIX ZEE JAY

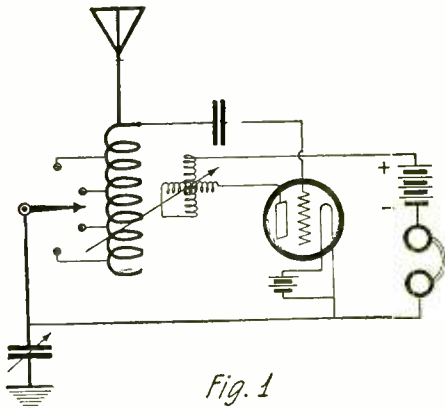

Fig. 1  
A Two-Circuit Receiver Employing the Inductance Variometer. This is a Combination Tickler Feed-back and Tuned Plate-circuit.

SINCE the advent of Armstrong's regenerative and autodyne systems were completely published, a full realization of the inherent qualifications of his discoveries is not generally understood or else is not put to practical use. In circuit diagrams submitted and included in Armstrong's basic patents, he has illustrated methods whereby he makes use of both a tuned plate circuit and also a regenerative feed-back coupling, simultaneously. Today we see this very important factor given to the radio world, entirely ignored by the majority. Most of the manufacturers, who consider their type of receiving sets the ultimate in regenerative design use either the

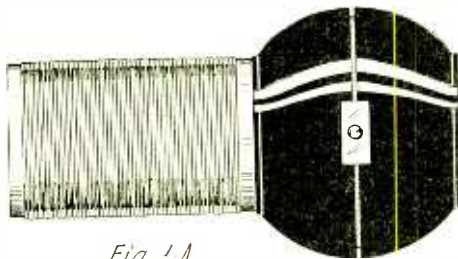

Fig. 1A  
General Appearance of the Inductance Variometer. It is no More Than a Standard Variometer with a Suitable Coil Attached to One Side, the Windings of Both Being in the Same Direction.

tuned plate or tickler coil feed-back methods but rarely both!

It is the purpose of this article to show to the reader a method whereby advantage can be taken of both tuned plate and tickler coupling, the combined effects of both producing an increase in signal strength over either method used separately. A marked degree in the increase of selectivity will be noted, as well as allowing the circuit to oscillate and regenerate over a wider wave-band.

### INDUCTANCE-VARIOMETER

To obtain these double features, an in-

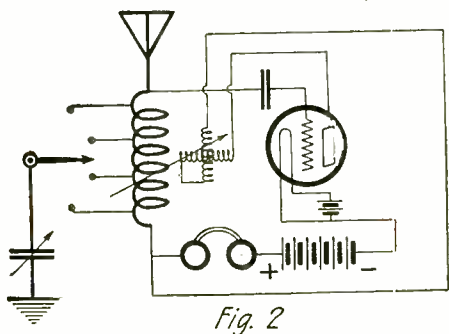

Fig. 2  
Identical With Fig. 1. Except the Phones and "B" Batteries Are Taken Out of the Oscillating Circuit.

ductance is coupled on to the left-hand side of an ordinary variometer—the variometer being utilized to tune the plate circuit and the inductance functioning in the grid circuit. The inductance consists of a number of turns of most any size of copper wire, preferably No. 22 D. C. C., wound on a 3½" bakelite or fibre tube. To embrace wave-lengths from 150 to 600 meters, 80 turns were wound on, taking taps at every 10th turn. However, if longer waves are contemplated, wind on a proportionately larger amount.

If a wooden form variometer is used, very little difficulty will be experienced in fastening the finished inductance on to the variometer. The writer used two small brass angles fastened diametrically opposite each other. Fig. 1A shows the inductance-

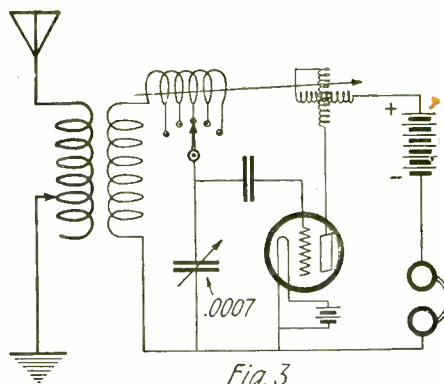

Fig. 3  
A Three-circuit Regenerative Receiver Employing a Variocoupler and the Inductance Variometer. This is Quite Selective.

variometer unit completed. There are several instruments on the market at present, similar to the one described, that can be adapted to the uses given herein.

### ADAPTED TO SINGLE-COIL CIRCUIT

Figs. 1 and 2 show circuit diagrams where the inductance-variometer is used in a single-coil circuit. Coupling the grid and plate

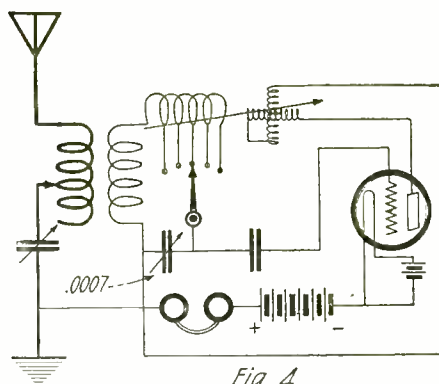

Fig. 4  
A Three-circuit Regenerative Set Similar to That of Fig. 3.

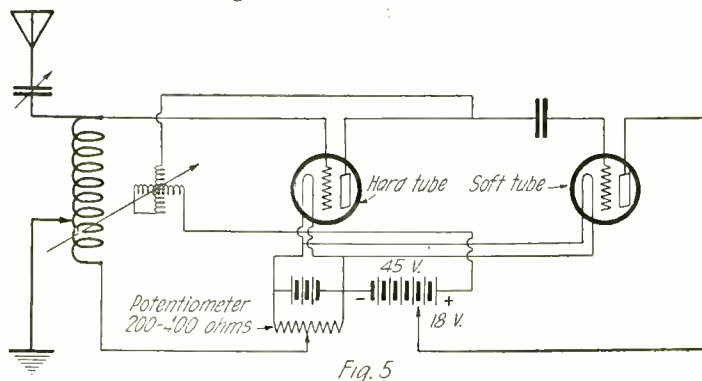

Fig. 5  
Here the Variometer Portion of the Inductance Variometer is Used as a Radio Frequency Amplifier of the Tuned Impedance Type. In All of These Circuits, Except Fig. 7, the Positive of the "B" Battery Should Connect to the Negative "A" Battery.

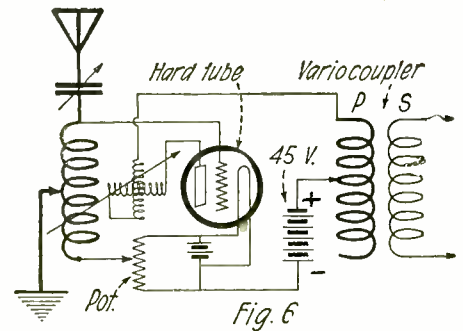

Fig. 6  
Employing the Inductance Variometer in Conjunction With a Variocoupler, the Latter Acting as a Radio Frequency Amplifying Transformer.

circuits gives increased signal strength over other methods without this novel feature. Also the selectivity of the circuit is greatly increased—a feature heretofore not seen in single-coil circuits. In the writer's opinion the circuit in Fig. 2 gives better results.

### ADAPTED TO THREE-CIRCUIT METHODS

In Figs. 3 and 4 are shown circuits where the three-circuit method is used. This circuit is very selective and is recommended where there are numerous broadcasting stations located in the vicinity of the receiver. Longer waves are also accessible, due to the secondary load coil being variable in step-

### ADAPTED TO RADIO-FREQUENCY AMPLIFICATION

Fortunately, tuned impedance offers a

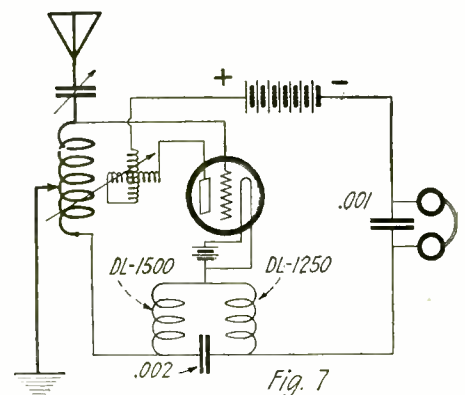
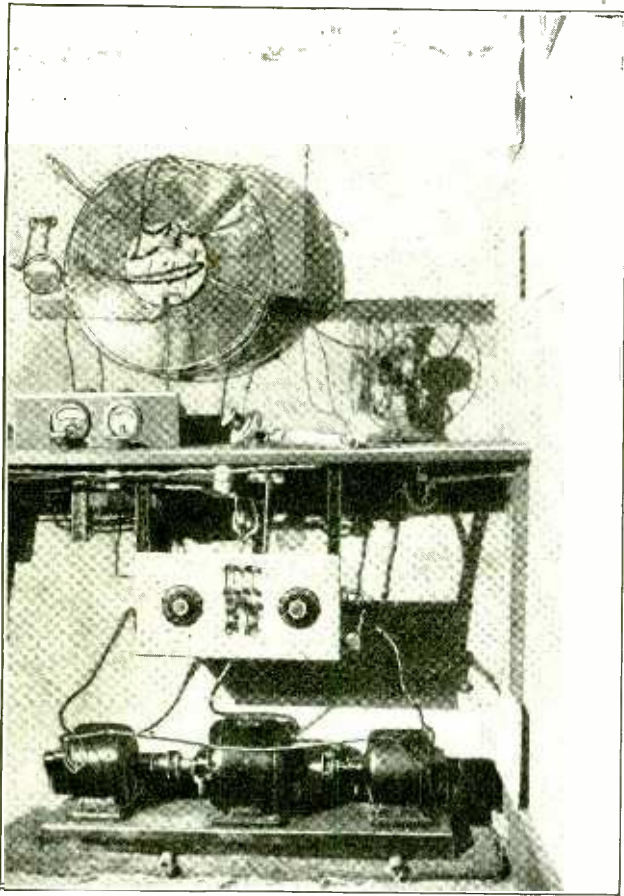

Fig. 7  
The Inductance Variometer Applied to a One-tube Super-regenerative Circuit. Note That no Grid Condenser and Leak Are Used.

means for coupling one stage of radio frequency to the detector. Using the variometer as the tuned impedance coupling, we see in Figs. 5 and 6 methods for a one-step radio frequency amplifier. By coupling the grid circuit to the plate circuit, a sort of "reflex" action takes place that increases the selectivity and stability, tending to a more efficient operation of the amplifier. Better results would be had if the coupling could

(Continued on page 298)

# Awards of the C. W. and Phone Contest



A Photograph of Mr. Wade's 10-Watt C.W. and Phone Set. Note the Fan Used for Cooling the Transmitting Tube. The Motor-Generator Is Mounted on a Mat, to Reduce Vibration.

as 300 to 600 meters. No exceptional records were obtained until the set was tuned to 250 meters or below. Many experiments have been tried to determine the cause of this, and it was decided that the reason for this peculiarity was the low fundamental of the antenna system.

With the exception of the tubes, this set is completely home made.

The antenna is a modified fan 80' high. The top spreader is 25' long. The bottom spreader is 40' above the ground and is 16' long. The wires, which are 9 in number, are bunched 18' from the set, which is 25' from the bottom of the pole. The counterpoise is of No. 12 aluminum wire the same as the antenna. The counterpoise consists of 18 wires 45' long and 10' high. Using the counterpoise and antenna the length of the fundamental was found to be 100 meters. Using the ground instead of the counterpoise, raised the natural period up to 137 meters.

The motor-generator consists of a Westinghouse two pole 1/2-H.P. motor directly coupled to an advance Electric 600-volt 100-watt generator. Another generator has just been hooked onto the other end of the shaft, as may be seen in the photograph.

The filter system used with this set is mostly telephone condensers. The high voltage by-pass and filter condenser consists of a sufficient number of 2-M.F. phone condensers hooked in series-parallel to make the total capacity 4 M.F. to stand 600 volts. The filament by-pass condenser is made up of two 2-M.F. condensers hooked in series with each other and put across the three terminals of the secondary of the filament transformer, as shown in the diagram. The high voltage choke is an old coil that was salvaged out

## PRIZE WINNERS

**First Prize \$50**  
ARCHIE WADE, JR., 6GI  
465 N. Lake St.  
Los Angeles, Calif.

**Second Prize \$25**  
MR. H. E. CUTTING, 7ZL  
Bozeman, Montana

**Third Prize \$15**  
MR. W. E. SLABOUGH, JR., 8BNH  
142 S. Union St.  
Akron, Ohio

**Fourth Prize \$10**  
MR. HENRY J. ENGLISH, 9BYX  
844 West College Ave.  
Jacksonville, Ill.

**First Honorable Mention**  
MR. RICHARD BALLOU, 9CAR  
1705 Eight Ave., N.  
Fort Dodge, Iowa

**Second Honorable Mention**  
MR. F. DOBSON, 2CQI  
73 Trask Ave.  
Bayonne, N. J.

of a dilapidated wattmeter. It has an inductance of 1.5 henries.

The filaments are lighted by a home made 100-watt center tap transformer which gives 11 volts. This voltage is, however, very advisably run through two home made rheostats before being applied to the tubes.

The grid leak is 5,000 ohms of No. 40 German silver wire which was obtained from a voltmeter resistance.

The grid condenser is of the regular Dubilier type. The size of the conducting plates was calculated by the usual formula:  $C$  equals  $.0885 \frac{K S}{r}$ .  $C$  is the capacity of the condenser,  $K$  the constant of the dielectric, and  $S$  the surface area of one plate and  $r$  the thickness of the dielectric. Mica was used in this one.

The oscillation transformer is rather unusual, as may be seen from the picture. The (Continued on page 318)

## FIRST PRIZE

### The Ten Watt Set At 6GI-6XAH

By ARCHIE WADE, JR.

RADIO 6GI has been in operation since the last war. In that time the station, like most other amateur stations, has been completely changed many times with varying degrees of success. The last change, however, seems to be by far the best.

Every station has its full stock of regular long distance records for 200 meter work, so I will not clutter up the page by giving the numerous records made by this station on the common wave-length of 200 meters. The latest, best and the most unusual record hung up by this station was occasioned by the change of my 50-watt set, which was used on wave-lengths from 300 to 600 meters, to a set of ten watts to be used on the short wave-lengths such as 100 to 250 meters.

The first time this station was operated on the untried wave-length of 100 meters the following results were obtained: Cards were received in two days reporting my signals QSA totaling a distance of over 85,000 miles for the first ten minutes of sending. By doing this, 6GI gained the honor of winning the short wave contest which has just recently been brought to a successful close. Many other exceptional records were also made using just ten watts on short wave-lengths while many of the other stations in the contest were using as high as 1/2 K.W. or even more in some cases.

The most unusual thing experienced at this station is that the set does not seemingly work efficiently on high wave-lengths such

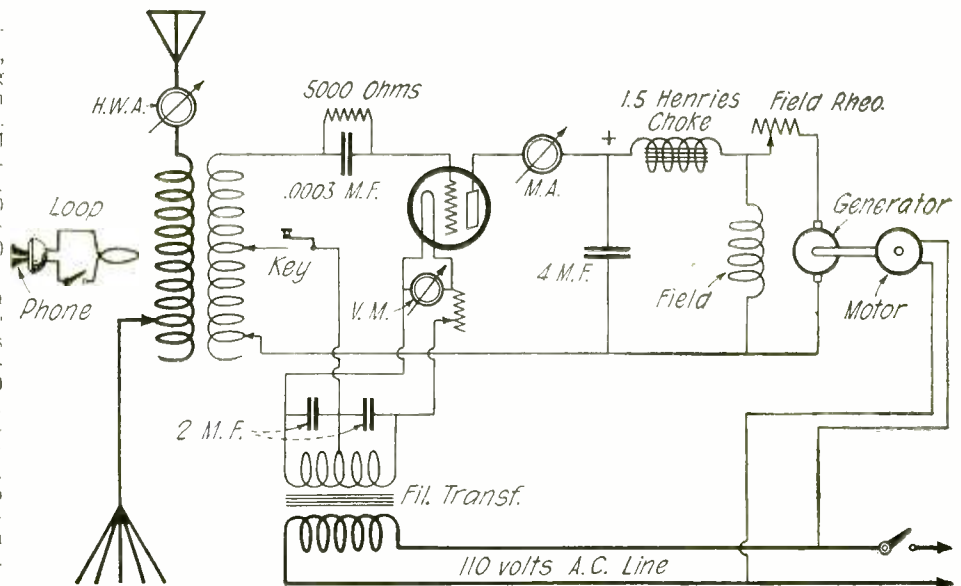

The Complete Circuit of the 10-Watt Transmitter at 6GI. Filament Current Is Obtained From the A.C. Supply Through a Step-Down Transformer. The Motor-Generator Supplies the Plate Current. Loop-Absorption Modulation Is Used for Phone Transmission.

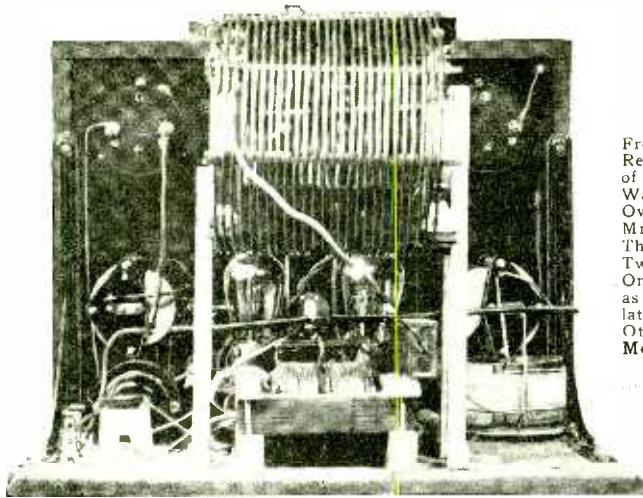

Front and Rear Views of the Five-Watt Set Owned by Mr. Cutting. There Are Two Tubes. One Acting as the Oscillator, the Other as the Modulator.

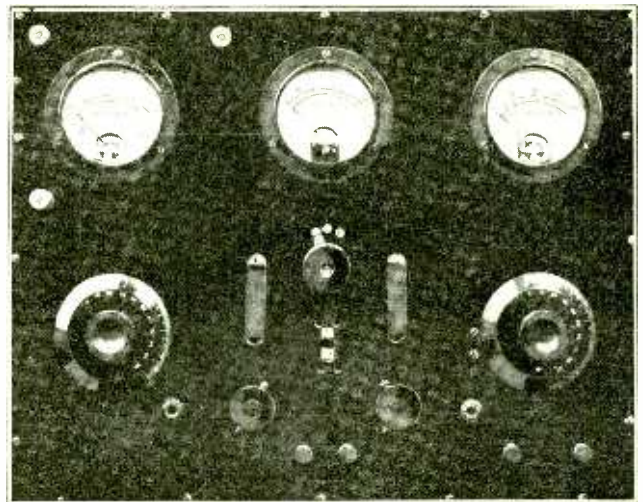

## SECOND PRIZE Five-Watt C. W. and Phone Set

By H. E. CUTTING, 7ZL

THE following described C.W. and phone transmitter was built by the author some six months ago and has given excellent results. For various reasons the circuit that was chosen for this set was the Colpitts Oscillator, as it was desired to use a counterpoise. The modulator chosen was the Heising, which is the only real system of modulation. With the settling of the circuit to be used the choice of apparatus was the next consideration. As I was desirous of getting the set on the air with a minimum of labor and in a short time, all the apparatus that suited the design was purchased outright.

The panel is a  $\frac{3}{8}$ " piece of bakelite 14" by 18" in size. It was first laid out as shown in the figure and the necessary holes were drilled. Then the base was attached and braced on by means of iron brackets so that the whole formed a rigid unit. The instruments were then mounted on the base and panel in the following order, which made assembling easy. Rheostats, jacks, binding posts, condensers, H. C. mounting, sockets, modulation transformer, grid leak, grid choke, high voltage shunt condenser, filament transformer, meters and last the inductance, which was fitted but not fastened.

The transmitter is now ready to begin wiring. With a clear copy of the circuit to be used before you and a red pencil to draw over each connection as it is made, start to wire. First connect up the rheostats and the filament leads to the tubes and the trans-

former. These leads should, by the way, be of either copper or brass strip about  $\frac{1}{2}$ " wide and fairly thick. This being done, start from where the high voltage enters the panel and wire through the modulator tube, radio frequency choke, oscillator tube and isolation condenser. Then on the negative lead go to the milliammeter and thence to the center filament and ground. Now wire the grid of the modulator tube to the bias

denser and with the completion of a clip for the aerial and counterpoise all is done with the exception of the filament voltmeter. This is wired with the switch so that the voltage on either the oscillator or on the modulator filament may be measured by a throw of the switch.

A suitable filter system should be built in a separate panel and may well consist of a couple of 3-henry chokes of 500-milli-ampere capacity shunted on the input and output ends by two 1-M.F. 1,000-volt condensers. This may seem rather liberal for a 5-watt set, but by so making it the cost is not raised greatly and if ever desired it will function with 50 watters. The filter used with the set at present is one from a Signal Corps 67A set.

The inductance was built up by the writer and consists of 25 turns of No. 10 soft copper wire wound on bakelite strips with an outside diameter of 7 inches. This gives a range with an aerial whose fundamental is 176 meters, or from 190 to 260 meters, which is more than ample. There are six bakelite strips equally spaced around the periphery of the 7-inch wood circles. The strips have grooves cut in them to secure the wire which was wound on with all the tension that it was possible to give it. The completed instrument was then mounted by three legs fastened to the wooden ends, so that it sets well up over the filament transformer. If desirous, lugs of copper may be soldered to each turn to facilitate clipping, but is not necessary.

The tuned choke in the grid circuit was made by winding 25 turns of No. 18 magnet wire on a  $3\frac{1}{2}$  inch form then shunting this by a 23-plate condenser. This will give with such a coil and condenser a range of from about 150 to 400 meters which is more than ample.

The tuned choke in the plate circuit is in my case a 250-turn honeycomb coil tuned to resonance by a 13-plate condenser.

In tuning the set up it is best to remove the modulator tube and if a source of high voltage A.C. of about 400 or 500 volts is available use this until the set is tuned. First light the tube till the proper voltage is indicated (7.5) and it is well to remember that you gain nothing by crowding the tube filament to gain a few extra tenths radiation. Place the antenna and plate clips close together and the grid clip between these and the counterpoise clip. Apply the high voltage and note the reading of the plate meter and the antenna meter. Now adjust the grid tap until the greatest radiation is secured, then see if better can be obtained by adjustment of the plate or counterpoise taps. If not then turn the condenser across the plate choke till the plate current drops, then turn the condenser across the grid choke until the plate current again drops, at which point the antenna current will raise slightly.

(Continued on page 320)

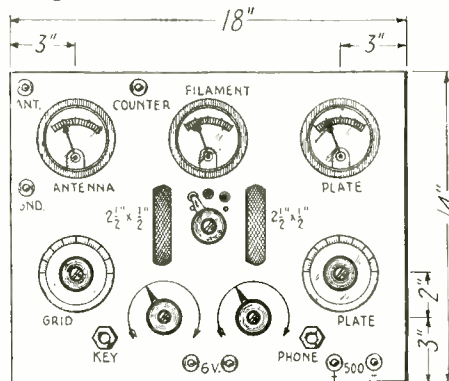

Constructional Details of the Panel Layout. All the Necessary Dimensions Are Given.

battery terminals, modulation transformer secondary and to the negative high voltage post. Next wire from the oscillator grid to the grid condenser and to the choke coil with its shunted condenser, thence through the grid leak to the ground post. Now the inductance may be mounted in place and a flexible lead run from the open side of the grid condenser to a clip to be fastened on the inductance, another lead and clip connects to the open side of the isolation con-

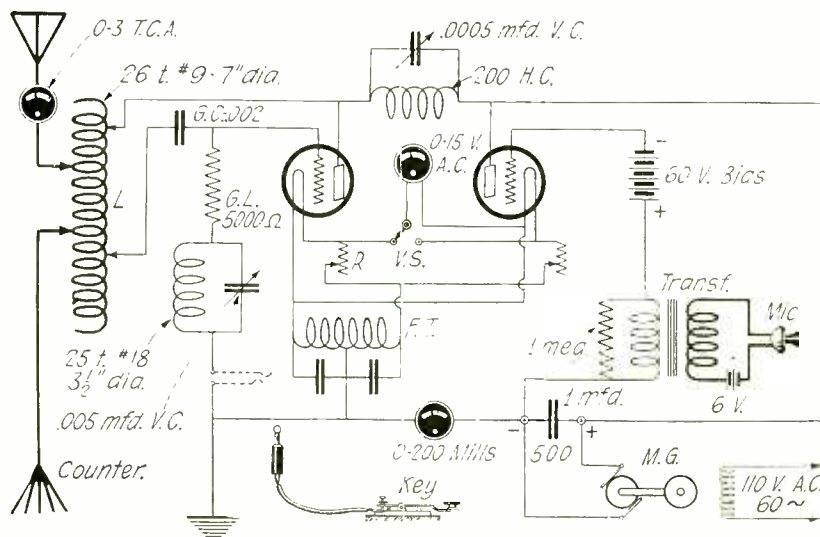

The Colpitts Oscillator Circuit Was Used in Preference to all Others. These Are the Exact Connections as in the set Described.

# Awards of the \$50 Radio Wrinkle Contest

## First Prize A PANEL SWITCH By JOHN F. BRONT

Progressive design, as well as public demand, is pointing the way toward the simply controlled or uncontrolled receiver. The average person enjoying radio for the amusement or economic results obtained alone is averse to the manipulation of many knobs, handles, and dials in order to bring in the desired signals.

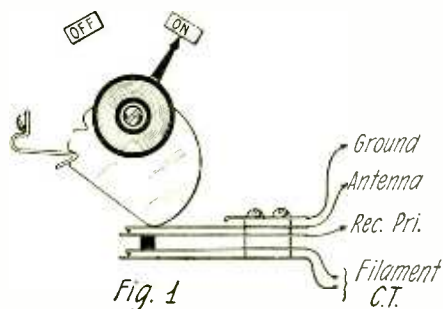

Full View of the Panel Switch, Showing How the Cam Bears Upon the Telephone Jack.

Herewith is illustrated the design for a switch which serves several purposes. When at the off position, the antenna is disconnected and grounded, thus guarding against damage from heavy static charges while the set is not in actual use. At the same time the filament circuits are opened and waste of current through carelessness in not cutting off the "A" battery is avoided. Possible failure of the antenna wires and possible contact with power wires resulting in damaged circuits is also avoided by grounding

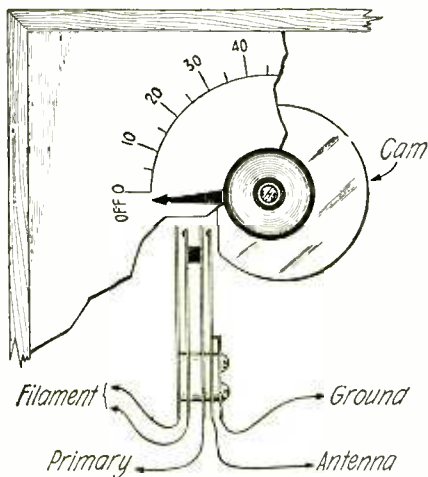

Another View of a Similar Arrangement, Which Can Be Attached Directly to the Shaft of the Tuning Variable Condenser.

of the primary lead from the antenna. The receiving transformer is disconnected.

At the on position the reverse of the above is true. All the operator is required to do when wishing to listen in is to throw the switch to the on side and the filament is lighted. The antenna disconnected from ground and connected to the receiver transformer.

The action and construction of the switch is simplicity itself. A cam of bakelite or other insulator is so shaped as to depress the jack leaves while in one position and to release them when at a certain point, which in this case is the off position. Fig. 1 shows the switch cam using a stop which works in

the notches and retains the cam at a desired position. In Fig. 2 is shown a similar application with the exception that the switch works automatically when the receiver inductance or condenser knob is moved to the tuning position. The filament and antenna circuits remain closed until the pointer is moved to the off scale position. If automatic filament current adjusters are used in the filament circuits, the use of the switch reduces the necessary manipulations required for placing the receiver in operation to a fewer number than heretofore.

## PRIZE WINNERS

### FIRST PRIZE, \$25

A Panel Switch  
By JOHN F. BRONT  
167 Stewart Street  
San Francisco, Cal.

### SECOND PRIZE, \$15

A Variometer With a Wide Range of Inductance  
By J. R. BALSLEY  
Ridley Park, Penn.

### THIRD PRIZE, \$10

A Convenient Aerial Lead-In  
By FREDERICK T. SWIFT, JR.  
57-63 West 45th Street  
New York, N. Y.

## Second Prize

### A VARIOMETER WITH A WIDE RANGE OF INDUCTANCE

By J. R. BALSLEY

Herewith is a description of a variometer that can be used to cover a wide band of wave-lengths without the necessity of employing a switching arrangement. It is especially adaptable to a Colpitts tuner, or as an inter-valve coupling for a tuned impedance radio frequency amplifier. This is in reality a 360° variometer, as the coils oppose each other at one parallel setting, thus affording a lower value of inductance, providing the windings of the coils are equal. As the rotor is turned through 180°, the inductance increases, until it equals the sum of the inductances of the two coils, viz., the rotor and stator. Continuing the rotation in the same direction, the coils are connected, to assist each other. Therefore, the inductance increases through another 180° until the maximum of self-inductance is reached,

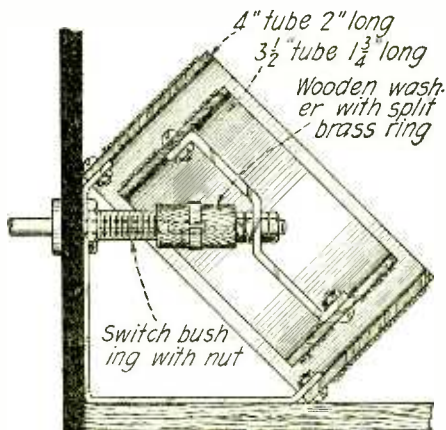

Fig. 1. Constructional Details of the 360-degree Variometer. The Two Brushes Are Attached Directly to the Front Panel and Make Contact With the Split Ring on the Wooden Washer.

when the coils are again parallel. This arrangement for switching the coils is accomplished by a commutating or switching arrangement that is mounted directly on the shaft of the rotor coil. This can be better understood by referring to the sketch, Fig. 1.

Due to this switching arrangement, a very large number of turns can be used on both the stator and rotor coils, with a corresponding broad range of tuning; 100 turns or more are suggested for each coil. Referring to Fig. 2, the variometer is connected as follows: One terminal of the stator coil is connected to a binding post. The second terminal of the stator is connected to one

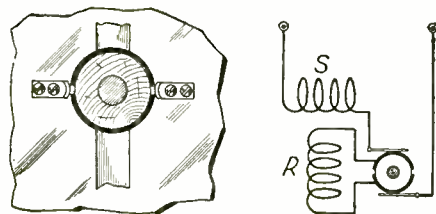

Fig. 2. A Section of the Commutator Arrangement and the Two Brushes, Showing How the Coils Are Connected to It.

brush, and the other brush to the second binding post. The terminals of the rotor are connected to the split ring on the wooden washer.

The construction of this variometer is very simple, as it is made of standard parts easily obtained. The details given in the sketches are self-explanatory. A variometer of this type constructed by the writer was used in the Colpitts circuit, where it efficiently covered all waves of from 200 to 3,000 meters. Each coil had a winding of 100 turns, these being bank wound in the usual manner, to save space.

## Third Prize

### A CONVENIENT AERIAL LEAD-IN By FREDERICK T. SWIFT, JR.

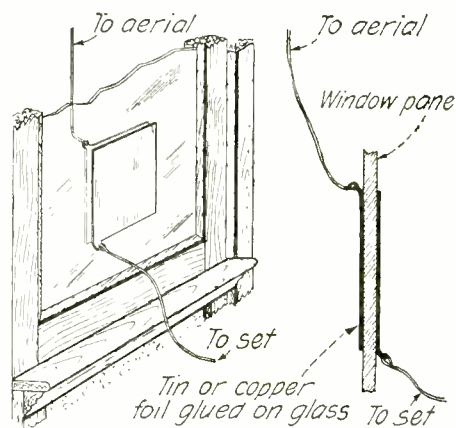

A Clever Stunt in the Form of an Aerial Lead-In. The Metal Sheets to Which the Wires Are Connected Act as a Condenser.

This idea is for little Willie, whose mother won't let him bring his lead-in wire under the window because in summer the mosquitoes get in, and in winter the cold gets in. The accompanying sketch illustrates the idea. On the outside of the upper pane of the window cement a piece of tin or copper foil of from 8" to 1' square, and connect this to the aerial lead-in wire. On the inside of the window pane, and directly opposite the outer sheet of foil, cement another sheet of the same dimensions. A wire is led from this directly to the aerial binding post of the

receiving set. These two sheets of foil, with the glass window pane between them, act as a condenser in series with the aerial. If it is necessary to have these two sheets smaller than the dimensions given, it is suggested that a variable condenser be connected in series with the inside sheet and the aerial binding post on the receiving set, as a small capacity tends to cut down the wave-length of the aerial proper. You hams who have transmitting sets will find this idea very convenient for use as a series antenna condenser.

**A GOOD LOUD SPEAKER**

An inexpensive, compact, light-weight, efficient, non-metallic loud speaker is a rare prize. We own three at our house, two of which represent a considerable investment. The third, and by far the most satisfactory one, is constructed of a ten-cent flower pot and a few bits of wood, cloth, rubber, brads and screws. It is of neat appearance and weighs only one and a half pounds. It can be built in about one hour.

Any hardware man who handles screen wire will give you the four wooden disks shown in the drawing. These are about 2" in diameter by 7/8" thick. Clamp two of these in a vise and bore two 1/2" holes edgewise through and between them, as shown. Bore a 3/4" hole through the center of the disks flatwise. Assemble the four wooden disks as shown, using brads and glue. The rubber gasket shown was cut from an old inner tube. Make rear end of 7/8" wood and bore as shown and use as template in drilling corresponding holes in bottom of flower pot. Two phone clamps made of strips of spring brass 1/2" wide are screwed

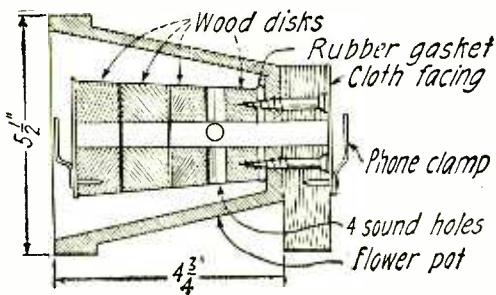

on where shown. Assemble these. Glue a woolen cloth phone gasket at each end of speaker. Glue three pieces of cloth for the feet, where shown. Paint with auto enamel.

This is the clearest and most distinct loud speaker for song and speech that I have ever heard. You will like it.

*Contributed by James Mechem.*

**REAR PANEL SWITCH STOPS**

Thinking switch stops are unsightly and detract from the appearance of a receiving set, I devised a unique method of eliminat-

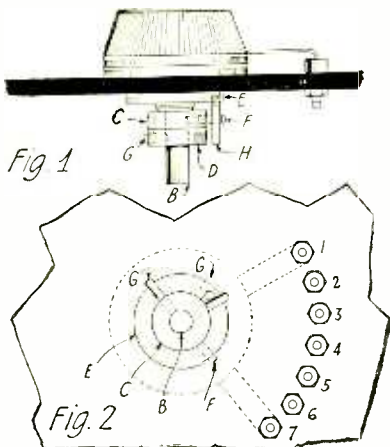

This Is a Good Stunt and Not a Hard One to Accomplish. The Switch Stops Are Mounted on the Shaft.

ing them. It is very simple, the only auxiliary parts necessary being three short lengths of brass rod, and an extra collar (D) in Fig. 1), from a discarded switch.

The set screws are removed from the collars (C) and (D), and two rods, after being threaded, are substituted. In the nut (E) a hole is drilled and threaded, and the third rod threaded and screwed in. Be sure that this hole is outside the circumference of the collars (C) and (D) when the switch is put together. It is assembled as shown in Fig. 1.

This switch may be adjusted to stop on the last of any number of switch points, by using the following instructions: Tighten the rod (F) of the collar (C) in the same plane as the switch lever, as in Fig. 2. The lever is put on the first point and the nut (E) turned until the rod (H) touches (F). The bushing is then tightened from the front side of the panel. Turn the lever to point 6, or 10, or whatever it may be, and tighten the rod (G), being sure it touches the rod (H), as in the diagram.

When the lever is turned to point 1, the rod (F) colliding with (H) prevents its sliding off the point onto the panel, while the rod (G) stops the lever at the right place at the other extreme.

*Contributed by J. C. Munday.*

**AMPLIFYING TRANSFORMER**

After reading over Mr. Arthur Vance's article in the Radio Wrinkle Contest for the construction of an audio frequency amplifying transformer, I started to make one myself. I took apart the Ford ignition coil carefully and removed the secondaries

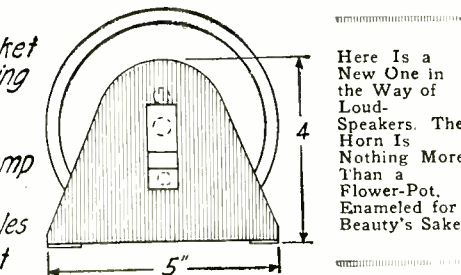

of same. Then the trouble began. In trying to separate the (one) secondary winding into two parts for the primary and the secondary windings of the amplifying transformer with a pocket knife as directed, I couldn't get the two parts separated. When I did separate them, the primary was nothing but a tangled mass of wires. I stopped to think for a moment as to what I should do next. Then I hit upon the following solution. I cleaned out the inside of the secondary (transformer) and soldered a rubber covered wire on the inside end of the winding and covered it with two or three turns of paraffined paper. Then I unwound the "left-over" secondary winding until it was just large enough to fit into the other winding snugly and connected both ends of the transformer primary to rubber-covered wires by soldering. A layer of paraffined paper was placed over the primary to prevent the larger wire from breaking into the secondary and the whole inserted into the secondary carefully. The transformer is then immersed in melted paraffin and when dried the core wires are bound in place as directed by Mr. Vance.

Many amateurs may have found this in constructing their transformers but many more may be thinking of building them so I thought this might save them a little trouble in the making.

*Contributed by Toshiharu Oka.*

**CONVENIENT METHOD FOR TAPPING COILS**

A very neat looking job of tapping tuning

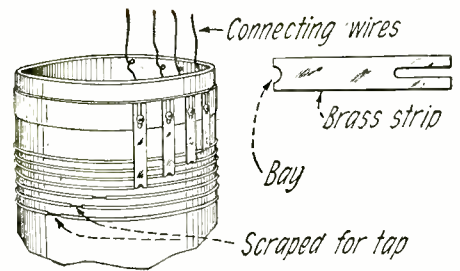

Not Only Does This Make a Neat-Looking Job, But It Insures a Ruggedness That Is Not Found in the Usual Tapped Coil.

coils can be done with little work in the following manner. The entire winding is done first with enameled wire, which insures tightness and neatness, after which about 1/4" of the selected turns are scraped of insulation with a knife.

The tapping leads are cut from stiff brass ribbon, as shown in the drawing, being about 1/4" wide, with a slot cut in one end, and a bay as wide as the diameter of the wire, in the other end. The slot should be wide enough to be slid on to a small screw fastened to the tube, by a nut on the other side. The lengths of the strips vary according to the distance of the tapped wires from the screws. The small bay at the other end permits soldering.

In order to bring the contacts exactly on the wires, the former should be bent slightly downward, and slid back and forth under the screws until adjusted. Connecting wires are fastened with another nut on the screws inside the tube. The wires in the drawing are shown spaced only for clearness.

*Contributed by Karl L. Martin.*

**AN EMERGENCY TUBE REPAIR**

It sometimes happens that the grid of a vacuum tube touches the filament or, if the vacuum tube is mounted horizontally, the filament may sag on the grid.

When this occurs some remedy is necessary, for the set will not operate with the audions in that condition. If the grid has not stuck to the filament, it can be jarred away by wrapping the tube on the palm of the hand. At times, however, this is not sufficient.

If you are not sure whether the grid and filament are touching, or something else may be wrong, you can find out easily by connecting two volts from one cell of your storage battery across one of the filament contact pins and the grid contact pin. If one-half the filament lights, you may know that they are touching. Do not apply the full voltage, for that might burn out the filament with only one-half of it offering resistance in the circuit.

If the grid and filament are stuck together connect both filament terminals together and put two volts across the grid and filament connections. Then, while the filament is dimly lighted strike the tube on the palm of your hand gently. This will cause the grid to become disengaged. Then it can be jarred back into its place.

*Contributed by M. B. Sleeper.*

**A PANEL MOUNTED COIL**

This coil, unlike the usual type, is wound through instead of around the core. The tuning or variation of inductance is accomplished by adjusting a knob and dial on the front of the panel, which is attached to a rod having on its end a switch-arm, or other suitable means for making contact with the edge of the coil farthest from the panel. The insulation is scraped off the wires on this edge in order to make the necessary contact between the switch-arm and the successive turns on the coil. A flexible lead is attached to the switch-arm and connected to the ground binding-post. A lead from

*(Continued on page 321)*

# Definition of Radio Terms

**T**HE following definition of technical terms and symbols used in radio was compiled by the Committee on Standardization, under the auspices of the Institute of Radio Engineers. This report is reprinted by special permission.

## DEFINITION OF TERMS

**Absorption Modulation:** The process of varying the amplitude of a radio-frequency alternating current in accordance with any desired wave form by systematically absorbing energy from the alternating current circuit in an element of a circuit which serves as an appropriately variable resistance. For example: Using the plate circuit of a three electrode tube as a variable resistance and varying such resistance by means of suitable voltages impressed on the grid; or, by coupling such a variable resistance to the antenna circuit of a radio transmitting set.

**Acceptor:** (See Rejector.) An acceptor is a supplementary combination of capacity and inductance tuned to the frequency of the desired signal, connected in series in the receiving antenna.

**Air Condenser:** A condenser having air as its dielectric, together with a minimum of solid dielectric used as mechanical support.

**Alternating-Current Characteristic:** The relation given by the curve obtained when the impressed emf. is plotted as abscissas against the resultant current as ordinates for alternating emf. and current.

**Alternating Current, Damped:** See Damped Alternating Current.

**Alternating Current, Forced:** See Damped Alternating Current.

**Alternating Current, Free:** See Free Alternating Current.

**Alternating Current, Undamped:** See

Undamped Alternating Current.

**Amplification Factor:** The ratio of the change of instantaneous voltage between filament and plate to a small change of instantaneous voltage between filament and grid for a given constant plate current.

$$\mu = \frac{\delta v_p}{\delta v_g}$$

**Amplifier:** A device which modifies the effect of a local source of power in accordance with the variations of input power, and produces an increased output power.

**Antenna:** A device for radiating or absorbing radio waves.

**Antenna, Coil:** See coil antenna.

**Antenna Resistance:** An effective resistance which is numerically equal to the ratio of the average power dissipated

(Continued on page 351)

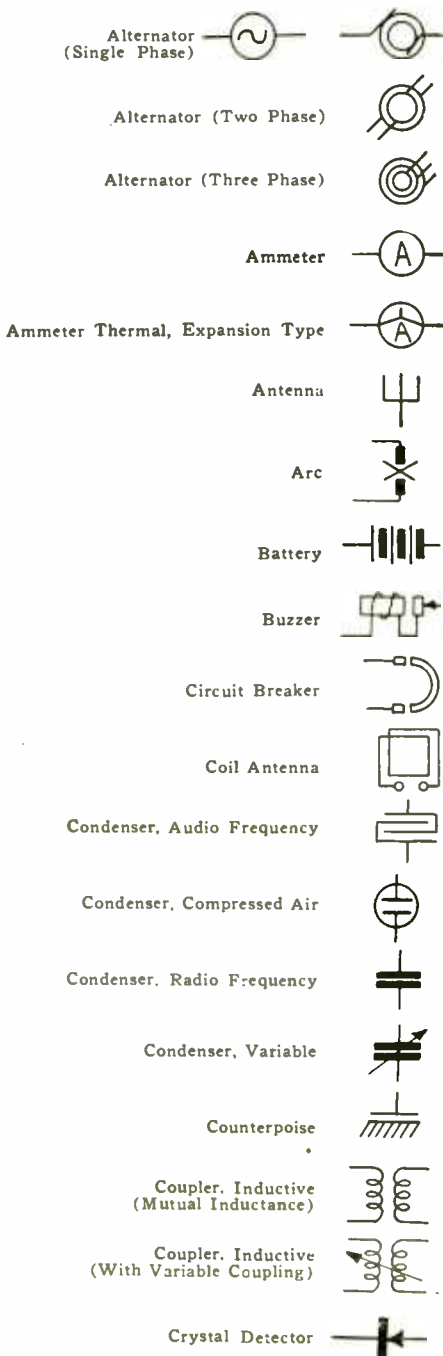

## Standard Graphical Symbols

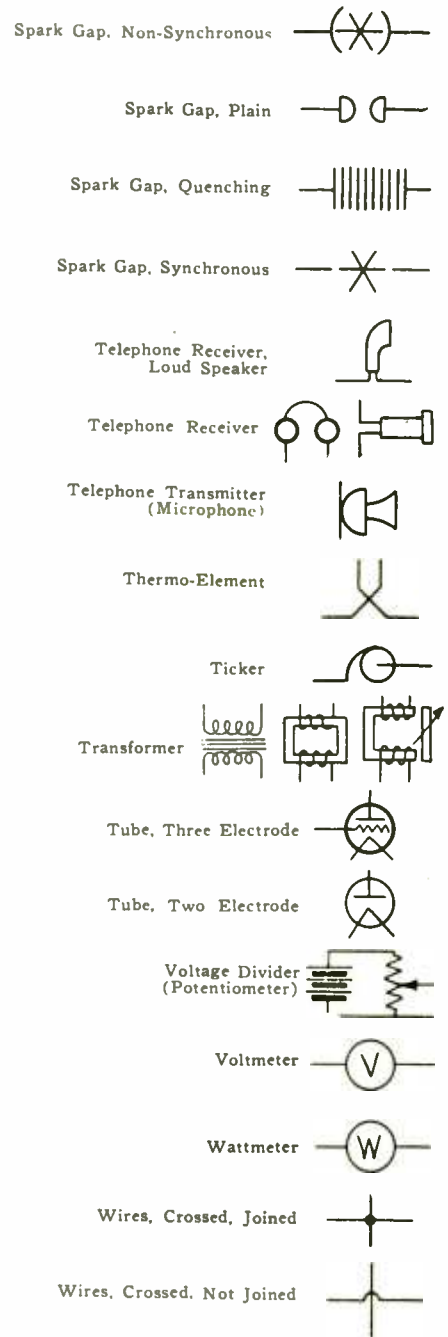
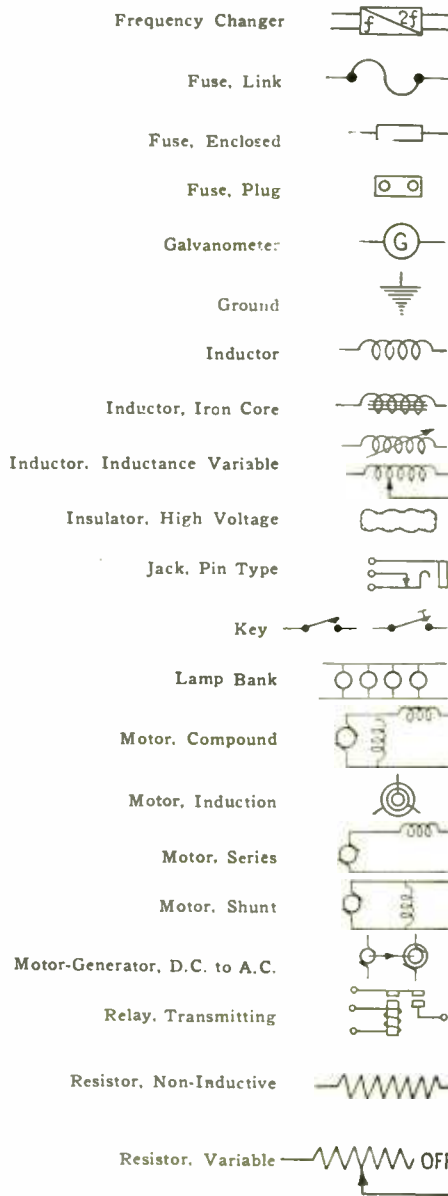

# Correspondence from Readers

## HIS RADIO GRIEVANCES

Editor, RADIO NEWS:

This is my first outbreak. Being of nature a rather peaceful cuss. I usually refrain from anything that smacks of rasciness. I have read RADIO NEWS for some time and thoroughly enjoy its pages. The squabble between the amateurs and B. C. L.'s, as we are called, made me "hot under the collar," but I decided, as usual, to let the rest pick the bone. I have my radio grievances as well as the rest of the bunch, but have thought it best in the past to ignore them. However, the "last straw" has arrived. I am sore clear through and, just to vent my wrath, I am going to tell the radio world how I feel about it all.

I am, first, sore at the amateur. My radio debut was made with the advent of broadcasting. Armed with numerous instruments, said to compose a radio set, I started the task of "making my own." The completed job was a thing well worth looking at, but nothing more. It absolutely refused to work. From numerous sources I had learned (?) that the radio amateur is a willing soul, and so I decided to hitch on to one in order to gain assistance. To make a long story short, after vainly telling my tale of woe to no less than five local radio amateurs, I gave up the job. None of them had the inclination to give me a hand. Understand that I realize the B. C. L. is very often a pest, and that it is not necessarily the amateur's duty to give assistance, nor the B. C. L.'s to expect it, but whence came these reports of the able, courteous and willing amateur? My experience has left me more than doubtful.

My second grievance is with a number of radio periodicals. Like the rest of the uninitiated B. C. L.'s, I have bitten more than once on the marvelous circuits published, only to find later that they were old standbys, shifted around so as to be practically unrecognizable. Why is it necessary to dupe us in that way? Do the instigators realize that many of us tear our sets down for the purpose of rewiring in the "new manner"? Is this fair play, I ask? Are the majority of the publications so low down that they have to gain popularity, plus circulation, by the printing of such trash? Can we not at least have the truth for our money? One small thing for them to remember is that the public cannot be duped forever; the truth will out!

Last, but not least, on my list of grievances is the radio dealer. Of all the punk business policies, the radio dealer has made a collection of the worst. They take entirely the wrong attitude towards their customers, in that they lack the courtesy and the desire to make a deal satisfactory. The tendency of the radio dealers to slip *anything* over on the public will eventually kill their business. Selling a man a fixed grid condenser when he wants a grid condenser and leak combined is very poor policy. Such incidents occur every day. Their present independence, due to the great demand for apparatus, cannot last. If service is not extended to the public, the public should boycott them.

As a suggestion to all radio dealers, why not employ a man thoroughly versed in the technicalities of radio, his business to be the imparting of information to customers who need help in the selection of the proper apparatus for their receiving sets? The salary paid to such a man would easily be covered by increased sales. As a warning to radio dealers: Stop selling inferior apparatus and, above all, give the people what they want.

These subjects seem to me rather important and should enter into the consideration of all of you who are interested in radio.

What have you to say? S. L. FOSTER,  
1655 Michigan Boulevard, Chicago, Ill.  
(Personally we do not agree with Mr. Foster as to the first part of his accusation. We happen to know that a very great proportion of amateurs are only too willing to lend a hand to anyone interested in radio, if the request is put in the right manner. We would very much like to hear from amateurs and broadcast listeners just what their experience has been. It is our duty to promote amicable relations between the amateurs and broadcast listeners and we believe that this can only be accomplished by full publicity.)

As to the second accusation regarding the radio dealer, we are afraid that Mr. Foster is right in many respects. There are still many dealers doing business under this archaic system and we venture to say that they will not be able to stay in business for a definite period unless they change their methods. The suggestion that every wide-awake dealer should have a man seated at a desk to do nothing but answer questions is an excellent one, and one that will certainly repay the dealer in a very short time.—EDITOR).

## An Electric Dog

**Y**OU wave a stick at him and he follows you around. Nothing radio about this dog, but he works entirely by electricity. One of the cleverest devices designed in recent years which any experimenter can build.

## What Do You Do With Your Old Spark Plugs?

**PRACTICAL ELECTRICS** has instituted a \$100. prize contest for best uses. If you have a good Radio use for old spark plugs, send in your contributions to **PRACTICAL ELECTRICS**. Other Interesting articles in the September issue of **PRACTICAL ELECTRICS**.

### Thermo-Couple Pyrometer

By Clyde J. Fitch

### Cutting Metals with Electric Arc

By A. M. Candy

### Electric Damper Regulator

By George C. McVicker

### Toy Motors

### Small Transformers

### Repairman's Test Panel

By B. M. Blount

### Sending Pictures by Wire

By Noel Deisch

### Electrolytic Rectifiers

### Magnet Tricks

## MANUFACTURERS TAKE NOTICE

Editor, RADIO NEWS:

Why do manufacturers take so much time in remedying or replacing defective apparatus when in most cases the transaction or repair work could be accomplished the same day, the customer 100 per cent satisfied and the firm's good will more firmly established? As a rule weeks slip away—sometimes months—letters follow in complaint, the adjustment finally follows, but a customer has already been lost, and, further, the news is spread: "Don't buy so-and-so's apparatus," says the disgruntled purchaser, "for it will take weeks to get an adjustment if any of their products fail to measure up."

This long-winded principle seems to me a very short-sighted view to take and certainly loses business for any concerns who are thus lax. I speak with authority, because in my own case I have met such experience. and because of slow response will abstain absolutely from using the products of a certain manufacturer in the future, no matter how high grade their apparatus may be.

JOHN U. GLOUSE, Rochester, N. Y.

## LET THE AMATEUR HELP YOU

Editor, RADIO NEWS:

This letter is in reply to Mr. W. W. Brakenridge's letter published in the July issue of RADIO NEWS. He says the amateurs give the single circuit tuner the "razzberry" and that a large number of the amateurs use this tuner themselves. I agree with him all through his letter, but where the difference comes in, the average B. C. L. does not know a thing about the operation of the set he owns! All he knows about tuning is to put his hand on the various knobs and start turning them. And when he can't hear anything it is blamed on the no-account, good-for-nothing except to trouble them, as they look on us narrow minded! All the interference from arc lights are blamed on us, but, Mr. B. C. L., you forget that of all such interference we get our dear share. We try to trace down the QRM and do our best to remedy anything that can possibly be remedied.

We are always glad to help any person who will heed what we say when helping him, but as most all amateurs already know, most all of our helps to the B. C. L. are thankless and the B. C. L. doesn't appreciate it any more than if it did not even concern him!

When the B. C. L. starts listening to the old timer, the amateur, and begins to try to learn how their set should be operated, there will be no more quarreling between he and the amateur.

If there are any amateurs in your city, Mr. B. C. L., I advise you to look them up and go around and meet them. But do it expecting to be benefited yourself by your visit and not you benefiting the amateur. When he starts to tell you something, listen to him as you are the pupil and not the teacher. Thank him for all his help and tell him in a friendly way of your troubles and interferences and invite him around to see your set and he will be more than glad to help you if you treat him as a human being. Try this and let the RADIO NEWS know your results.

JOHN T. PORTER, Radio 5AKZ,  
Alamogordo, New Mexico.

## AMERICAN AMATEURS QRM IN NEW ZEALAND

Editor, RADIO NEWS:

I will give you a list of American amateurs picked up on the 29th and 30th of April. Two valves were used and once while using only one, which was a Myers tube, one message was intercepted. Static interfered to a great extent and it was almost impossible to read the signals. Tuning was extremely sharp, using a .0005 mfd. with Connecticut vernier in series with primary coil.

5PX was calling CQ and 6AO. 5BQ gave his address in Alabama. I think this is a good record for long distance receiving. Other calls heard were (1BQC or 1BZC, 6BRF, 1BCF, 5HA, 6BH, 6AP).

May 4th heard 6ZG calling Australia; 6JD calling CDO.

May 5th heard 6CGW calling (test) Australia; 6CGW calling 5ADO; 6CGW calling 9AIX; 6CGW calling 5PX.

Other stations were heard, but owing to heavy atmospherics it was impossible to read them. 6CGW was easily readable on one tube.

May 10, 6CGW calling Australia sending also TJ.

May 12th, 6AAK calling CQ, 6:25 p. m.; 6CGW calling Australia; 6CMV calling.

May 15th, 6AWX calling Australia; 6ABX calling Australia test (code word,

(Continued on page 321)



## Apparatus Awarded Certificates

### ROLLER-SMITH UNIVERSAL HEAD-SET

The 2,000-ohm head-set which is shown in the illustration, is manufactured by the Roller-Smith Company, of Bethlehem, Pa., and was found to have 2,050 ohms resistance. This head-set is very sensitive to weak signals and also reproduces the loud signals and concerts without distortion. They are

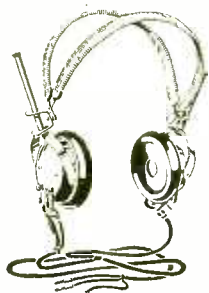

of the standard construction, employing two center magnetic poles having  $9/16 \times 3/32$ " tips. The shell is of metal and the caps are hard rubber. Tests were made at frequencies ranging from 200 to 4,700 cycles per second.

Arrived in good packing.

AWARDED THE RADIO NEWS LABORATORIES CERTIFICATE OF MERIT NO. 179.

### NEWMAN-STERN RED-HEAD PHONES

The "Red-Head" receivers, which are manufactured by Newman-Stern Co., of Newman-Stern Building, Cleveland, O., are shown in the illustration. These phones, marked 3,000-ohms resistance, were found to have a resistance of 2,812 ohms. They were tested at frequencies ranging from 200 to 4,700 cycles per second, and were found to be very sensitive to both weak and loud



signals. They are of the standard size and construction, having two  $9/16 \times 3/32$ " magnetic pole tips. The shell is of metal and the caps of red insulating material. The head-band is so designed that the head-set can be worn with comfort.

Arrived in good packing.

AWARDED THE RADIO NEWS LABORATORIES CERTIFICATE OF MERIT NO. 183.

### FOOTE DETECTOR CRYSTALS

The Foote Mineral Company, Inc., 107 N. 19th Street, Philadelphia, Pa., submitted a box containing 50 small tin boxes of various radio crystals. There were three types of



crystals submitted, viz., galena, pyrite and silicon. The crystals are mounted in an alloy having a  $1/2$ " diameter projection, so that they can be clamped in a standard  $1/2$ " detector cup. Single, double and triple-mounted crystals were submitted. There were in all 15 single galena crystals, 10 single pyrite crystals, five single silicon crystals, 10 double mountings of galena and pyrites, and 10 triple mountings containing galena, pyrites and silicon. All were tested and found to be very sensitive, but the galena, as was expected, was the most sensitive. Instruction sheet and diagram were furnished in each small metal box of crystals. The crystals are wrapped in tinfoil.

AWARDED THE RADIO NEWS LABORATORIES CERTIFICATE OF MERIT NO. 178.

### ERNEST HEAD-SET

The head-set shown in the illustration is of the standard size and construction, and was found to give good results on both weak



and loud signals. Although marked 3,000-ohms resistance, the phones were found to have a resistance of 2,680 ohms. The shell is of metal with black insulating caps. The pole tips measure  $7/8 \times 1/8$ " and are slightly flattened out. This head-set is manufactured by the Ernest Electric Company, 4847 Easton Avenue, St. Louis, Mo.

Arrived in good packing.

AWARDED THE RADIO NEWS LABORATORIES CERTIFICATE OF MERIT NO. 189.

### MULTIPLE ELECTRIC HEAD-SET

The Multiple Electric Products Company, 36 Spring Street, Newark, N. J., submitted for test the phones shown in the illustration. Although not marked, the phones were found to have a resistance of 2,140 ohms. They were found equal to the average as regards sensitivity to weak signals, and also gave excellent results on the loud signals and concerts. The phones are of small size, the diaphragm measuring  $1 \frac{1}{13}$ " in diameter,

and are of the standard construction, having two magnetic poles with tips measuring  $1/4 \times 3/8$ ". The ends of the spools are of metal, which are slotted so as to reduce losses due to eddy currents. The shells are of metal and the head-band is so shaped that the head-set can be worn with comfort.

Arrived in good packing.

AWARDED THE RADIO NEWS LABORATORIES CERTIFICATE OF MERIT NO. 185.



### CIC HEAD-SET

The head-set manufactured by the Connecticut Instrument Co., Inc., Stamford, Conn., is somewhat different from the ordinary kinds, in that the diaphragm is of insulating material, having a small iron armature fastened to its center, which armature is actuated by the two magnetic poles in the phone. The ear caps are very large so that practically all external noises can be excluded while wearing the phones. The resistance was found to be 2,499 ohms. While not so sensitive to the weak signals, it gave excellent results on loud signals and would reproduce these loud enough to be heard over the entire area of a large room.

Arrived in good packing.

AWARDED THE RADIO NEWS LABORATORIES CERTIFICATE OF MERIT NO. 186.



### THE EZTOON DIAL

This dial, which is manufactured by the Butler Manufacturing Co., 3234 W. Washington street, Indianapolis, Ind., is unique in that it employs a self-contained vernier attachment, thus putting a vernier adjustment on any tuning unit upon which it is mounted. This is accomplished by means of a spiral-shaped cam which actuates a lever arm when the small vernier knob is turned. This motion turns the large dial at a ratio of 40:1, thus providing very fine control. A hushing



is supplied with each dial so that it can be mounted on either a  $\frac{1}{8}$ " or  $\frac{1}{4}$ " shaft. Dials are made in both 3" and 4" sizes.

Arrived in excellent packing.

AWARDED THE RADIO NEWS LABORATORIES CERTIFICATE OF MERIT NO. 190.



**CROSLY TWO-STEP AMPLIFIER**

The Crosley Manufacturing Company, Blue Rock street and B. & O. R. R., Cincinnati, Ohio, submitted for test one of their two-step audio frequency amplifiers. This unit is compact in size, measuring only 11" by 6" by 5" over all. Binding posts are provided for the input, the "A" battery, and the phones or loud talker. Two flexible leads with clips, passing through the back of the cabinet, make excellent "B" battery connections. Two rheostats provide control for the current flowing through the filaments of the two vacuum tubes inside. Iron-core audio frequency amplifying transformers are used in this outfit. Excellent results were obtained on broadcast reception when used with a 45-volt "B" battery.

Arrived in excellent packing.

AWARDED THE RADIO NEWS LABORATORIES CERTIFICATE OF MERIT NO. 199.



**NATIONAL MONODYNE TUBE SET**

The National Monodyne single-control tube set, which is manufactured by the National Airphone Corporation, 20 Hudson street, New York City, is a very compact and simple vacuum-tube receiving set of pleasing appearance. This set is especially designed for use with a dry-cell tube, although any tube may be fitted into its standard receptacle. It is furnished with two inductance coils, one colored red and the other green. These enable the reception of waves of all lengths employed in modern broadcasting. The single-control knob operates a variable condenser inside. Great volume and clearness of the received programs were obtained, as the distortion and noise caused by regeneration in the usual sets are absent.

Arrived in excellent packing with instruction sheets.

AWARDED THE RADIO NEWS LABORATORIES CERTIFICATE OF MERIT NO. 203.



**"RICO" TUNED MELOTONE SPEAKER**

Simplicity in the design of loud-speakers seems to be the aim of the Radio Industries Corporation, 131 Duane street, New York City, in producing their "Melotone" speaker. This speaker underwent a severe test, and

has proven itself electrically efficient as well

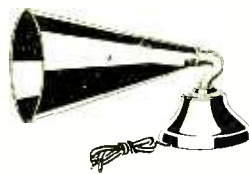

as of simple construction. The "Rico" loud-talker phone screws directly into the cast-metal base, thereby avoiding the use of the usual hard rubber phone cap. The base is finished in black, with a nickel-plated goose-neck. The horn is of fibre. The loud-talker is tuned by turning the phone, which varies the length of its magnetic air gap.

Arrived in excellent packing.

AWARDED THE RADIO NEWS LABORATORIES CERTIFICATE OF MERIT NO. 202.

**"RICO" LOUD-SPEAKER**

The tri-pole loud-talker unit which is shown in the illustration was found to possess great sensitivity to weak signals and would also reproduce radio concerts with much volume and with the minimum of distortion. The construction is similar to that of the tri-pole head-sets, employing an electro-magnet placed in a U-shaped permanent magnet at the center of the phone. The center pole is rectangular in shape, measuring  $\frac{1}{2}$ " by  $\frac{1}{16}$ ", so that the lengths of the



magnetic lines of force from the center pole to the side poles of the permanent magnet are uniform. Rubber gaskets underneath the diaphragm allow for adjusting the length of the air gap by turning the ear cap. This loud-talker phone is manufactured by the Radio Industries Corporation, 131 Duane street, New York City.

Arrived in excellent packing, with instruction sheet.

AWARDED THE RADIO NEWS LABORATORIES CERTIFICATE OF MERIT NO. 191.

**THOROPHONE LOUD-SPEAKER**

The Winkler-Reichmann Co., 4801 South Morgan street, Chicago, Ill., submitted for test the loud-talker shown in the illustration.



This loud-talker requires a six-volt battery for energizing the electro-magnetic field. It is of the electro-dynamic type, employing a movable coil, in a magnetic field, through which the telephonic currents pass. This coil is attached to a lever arm by means of which it actuates a mica diaphragm, similar to the ordinary phonograph construction. The horn is rather large and the instrument reproduces the received concerts with great

volume. The resistance of the unit is 1,440 ohms and the impedance, at 1,000 cycles, is 14,000 ohms.

Arrived in excellent packing.

AWARDED THE RADIO NEWS LABORATORIES CERTIFICATE OF MERIT NO. 193.

**BALDWIN CLAROPHONE LOUD-SPEAKER**



The loud-speaker shown in the illustration comprises a Baldwin type "C" phone and a novel shaped horn, specially designed to reproduce the received concerts with excellent quality. The resistance of the phone is 638 ohms; the impedance at 1,000 cycles is 16,400 ohms. This instrument was found to be very sensitive and excellent results were obtained when used on a three-tube receiving set with a 45-volt "B" battery. This loud talker is manufactured by the Master Radio Corporation, 631 South Spring street, Los Angeles, California.

Arrived in excellent packing.

AWARDED THE RADIO NEWS LABORATORIES CERTIFICATE OF MERIT NO. 195.

**TIMMONS TALKER**

J. S. Timmons, Germantown, Philadelphia, Pa., submitted a sample "Timmons Talker" to us, which is shown in the illustra-

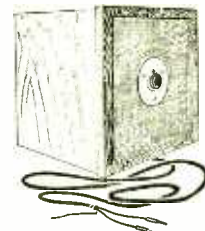

tion. This loud-talker is very neat in appearance and was found to be very efficient electrically. A knob at the front is used to vary the length of the air gap in the loud-speaker unit, thus adjusting the instrument for all conditions. This instrument readily reproduces radio concerts with great volume and with the minimum of distortion.

Arrived in excellent packing.

AWARDED THE RADIO NEWS LABORATORIES CERTIFICATE OF MERIT NO. 192.

**SPIES HEAD-SET**

The 2,500-ohm phones submitted by the Spies Electric Works, Chicago, Ill., were found to be very accurate as regards re-



sistances, as they measure exactly 2,500 ohms. They were found very sensitive to frequencies ranging from 200 to 4,700 cycles per second. They are of the standard construction, having two poles with tips measur-

(Continued on page 337)



## Pointers for Would Be Operators

By FRANK MAYER



A Splendid View of the Receiving Apparatus Aboard the S.S. Leviathan. To the Left Is an Eight-Tube Duplex High-Speed Receiver, and to the Right an Eight-Tube Navy Standard Long-Wave Receiver.

**T**HE average time of service of a Professional Radio operator is about nine months. This low average is due to the fact that a fair judgment of the individual's adaptness as a radio operator can be reached only after he has been thrown on his own resources under actual operating conditions, such as static, heavy jamming in the ether, break-downs of apparatus and heavy weather. Many resign after the first voyage, disillusioned, either by the comparatively small hardships and monotony aboard a freighter, continuous seasickness or with the knowledge that to be a successful radio operator they require an immense amount of patience, lack of which would create a dangerous strain upon their nervous systems. Many others are rooted out of the service after they have shown their unreliability or their inability to adjust themselves to the rigid discipline of the sea. Many who have had an excellent record aboard freight steamers meet their Waterloo after being rewarded with a berth aboard a passenger vessel. It appears to be very hard for them to realize that they are employed by the Steamship Companies as servants to the traveling public and as such cannot demand the same freedom and luxuries as passengers enjoy, nor that their intercourse with the traveling public, especially with the female of the species, can be of the same equality or freedom that fellow passengers enjoy.

Experience will teach you many things in time, but it is a wise man who can gain by the experience of others. Here are a

dozen Don'ts on the road to your success as a radio operator.

Don't start your set before you make sure the message to be transmitted is checked and every word intelligible to you. To break off in the middle of a message and QSK it, until you verify it, is absolutely idiotic and the delinquent should be suspended from the service. It is excusable only on large passenger vessels, where heavy traffic is handled and the operator gets a bunch of messages shoved in front of him, while transmitting, which are checked by some one else.

Don't help the automatic starter with your pencil, when starting your set. Three seconds thus gained, may result in many hours of hairpulling and hard work on motor or starter.

Don't call a station faster than you can receive. The other operator will invariably judge your receiving skill by your transmitting speed and come back at you at the same rate of speed.

Don't call a station after he tells someone else to go ahead, you jam the other operator's traffic, thereby delaying your own and if you insist on jamming in, it will not be long before you grace the carpet at your Home Office to be told what you are reading now and more.

Don't O.K. a message, unless you are sure of every word. You might guess wrong and have to service it later on. Those services are kept on file and do not speak very well for you.

Don't accept another fellow's traffic unless

you are sure that you can work the desired station yourself. Think how it feels to have your traffic bound up for hours and then have it flung back at you undelivered. The other fellow's log entry will be a black mark against your station.

Don't "chew the fat" and think you are getting away with it, because you are not signing off. Some station nearby may recognize your spark and sending. There are special log blanks issued by most Governments and foreign ship operators who delight in making your station call immortal on one of them. It will be months before those loggings get into the hands of your local radio Inspector and you have the opportunity to realize how expensive those little conversations can be.

Don't try out your spark on 600 meters, after sundown. To adjust to synchronism, disconnect your antenna. It is much easier than walking into the Customs House to answer to a log entree. To adjust your transmitter to the point of maximum radiation, it is advisable to do this in the daytime, when no long distance traffic is being handled. There is no necessity to ask for QRK's; your meter in the antenna circuit can give you the answer. No other test is necessary hours later, if you made sure that all movable parts of the transmitter were tightly secured after the test.

Don't let your dignity prevent you from keeping all metal parts of your apparatus brightly polished and free from dust. As you can judge a man's character by the appearance of his shoes, so can you judge an operator's ability and love for his trade by the neat appearance of his instruments. Dust collecting in the transmitter will ultimately cost you more worries and labor, after a short circuit or puncture, than the little cleaning would have done.

Don't "knock" your instruments if you can't get your traffic off or receive properly. You are doing much harm to the radio company you are representing and it is really no excuse. If you had reported all faults to the Inspection Department, they would have had your set in proper trim before sailing.

Don't invite passengers to the Radio Room, although you may have that privilege on the vessel you are on. It distracts the watch operator's attention from his work and seems to create a certain element of jealousy among the other officers, who have not the privilege of entertaining passengers.

Don't misconduct yourself aboard a ship, or be a snob. Remember it took us many years of honest efforts and many disappointments to reach our now unquestioned status as ship officers. Five minutes of thoughtlessness on your part may destroy all those gains aboard that particular vessel for some time to come. You hold a Man's job; be one.

### EVERY "SKIPPER" HIS OWN FORECASTER

Within a short time, "Skippers" of ocean going vessels equipped with radio, will be  
(Continued on page 331)



**T**HIS Department is conducted for the benefit of our Radio Experimenters. We shall be glad to answer here questions for the benefit of all, but we can publish only such matter as is of sufficient interest to all.

1. This Department cannot answer more than three questions for each correspondent.
2. Only one side of the sheet should be written upon; all matter should be typewritten or else written in ink. No attention paid to penciled matter.
3. Sketches, diagrams, etc., must be on separate sheets. This Department does not answer questions by mail free of charge.
4. Our Editors will be glad to answer any letter, at the rate of 25c for each question. If, however, questions entail considerable research work, intricate calculations, patent research, etc., a special charge will be made. Before we answer such questions, correspondents will be informed as to the price charge. You will do the Editor a personal favor if you will make your letter as brief as possible.

**ANTENNA QUERIES**

(740) Mr. Herman P. Landbrook, Middleport, N. Y., asks:

Q. 1. How long should the antenna be including the lead-in, when it is about 35' from the ground?

A. 1. A single wire about 100' long will give very good results. Including the lead-in, the length will be about 125'.

Q. 2. Should the antenna wire run in one straight line, or could it be stretched in a triangular shape? My house is only 45' long and there are no trees or other houses near.

A. 2. For best results the antenna should run in a straight line, but, if the antenna is stretched from one corner of the front of the house to a pole in the center of the rear, and from there to the opposite corner on the front, very good results can be expected. The lead-in should be taken from one end of the wire at the corner of the house.

Q. 3. Which will give the greater volume, when using a loud-speaking phone with a phonograph, a single-circuit receiver or the Erla Duo Reflex Set?

A. 3. If correctly tuned, the Erla Reflex should give louder signals than the single-circuit receiver.

**A SIX-TUBE SUPER-HETERODYNE**

(741) Mr. Geo. Bartel, Dallas, Tex., requests:

Q. 1. Please publish a diagram of a Super-Heterodyne Receiver, using radio frequency transformers instead of resistances.

A. 1. This circuit appears in these columns. Iron-core transformers, designed to operate efficiently on 3,000 meters, are used.

**HONEYCOMB SET**

(742) Mr. Galen A. Grimma, Newkirk, Ohio, wants to know:

Q. 1. Would it be advisable to change a three-circuit honeycomb set to a single-circuit regenerative, using one or more of the honeycomb coils?

A. 1. There would be no advantage in changing a three-circuit receiver to a single-circuit one. The signals might be a trifle louder, but this would be offset by the resultant broadness of tuning.

Q. 2. Will a two-stage amplifier using WD-11's work well with a Radiotron UV-200 as a detector?

A. 2. This combination will give fair results, but we would suggest that for loudest signals UV-201A tubes be used in the amplifying unit.

Q. 3. Is a three-circuit honeycomb set as efficient as a single-circuit for broadcast receiving?

A. 3. A three-circuit receiver is much more efficient than a single-circuit. Although a bit more difficult to tune, it is far more selective and interfering stations can be tuned out much more easily.

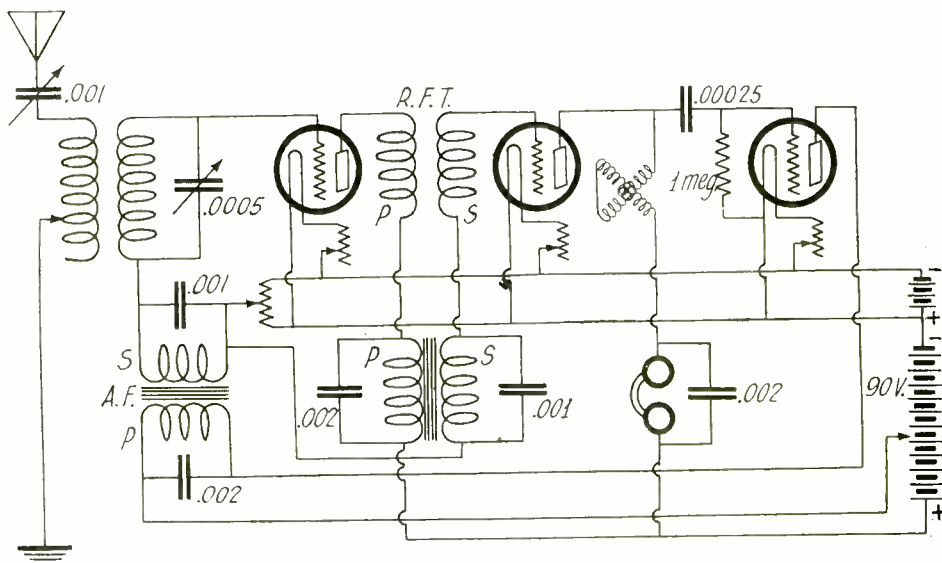

Q. 745. Tuned R.F. Amplification May Be Used in a Reflex Circuit by Following This Diagram. Only One Stage Is Tuned and It Must Be Next to the Detector.

**R. F. RECEIVER**

(743) Mr. O. H. Wheat, Belton, Tex., asks:

Q. 1. Please publish a diagram of a receiver using two stages of radio and two stages of audio frequency amplification, with filament-control jacks. Both outside and loop aerials are to be used.

A. 1. This diagram will be found in these columns. Filament-control jacks are shown in each stage of audio frequency. The first jack controls the filaments of the detector and two radio tubes. A double-circuit jack is placed in the secondary circuit of the tuner, so that a loop can be plugged in. A variometer is used to tune the secondary circuit, but this instrument cannot be placed in the plate circuit of the detector for regeneration, when radio frequency is used.

**TUNED R. F. RECEIVER**

(744) Mr. P. G. Swearingen, Jr., Houston, Tex., wants to know:

Q. 1. In the hook-up of the tuned radio frequency receiver in the July Hook-up number, a 200- to 400-ohm potentiometer is shown. Just what resistance does this mean?

A. 1. This means a potentiometer with a maximum resistance of from 200 to 400 ohms. A 300-ohm potentiometer will be satisfactory in this set.

Q. 2. Will this set receive all the wave-lengths in use by broadcasting stations at present?

A. 2. To receive the higher wave-lengths used by the broadcasting stations, it will be necessary to use a honeycomb coil of 75 turns for the tuned impedance coil; 50 turns of No. 24 S. C. C. wire on a 3" tube will give good results in this position.

**TUNED R. F. IN REFLEX**

(745) Mr. Leslie Clearwater, Wayland, N. Y., wants to know:

Q. 1. Is it possible to use variometers in place of R. F. transformers in a three-tube reflex circuit? If so, please give hook-up.

A. 1. One stage of tuned R. F. can be used in conjunction with one stage of transformer-coupled R. F. in a reflex circuit. The tuned R. F. must be placed in the second stage. A diagram will be found on these pages showing the correct circuit.

Q. 2. How do results obtained with such a

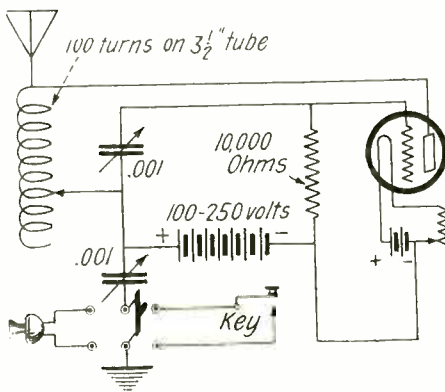

Q. 749. This Diagram Shows a Simple C.W. and Phone Transmitter That Will Give Good Results. A D.P.D.T. Switch Is Used for Voice or Key.

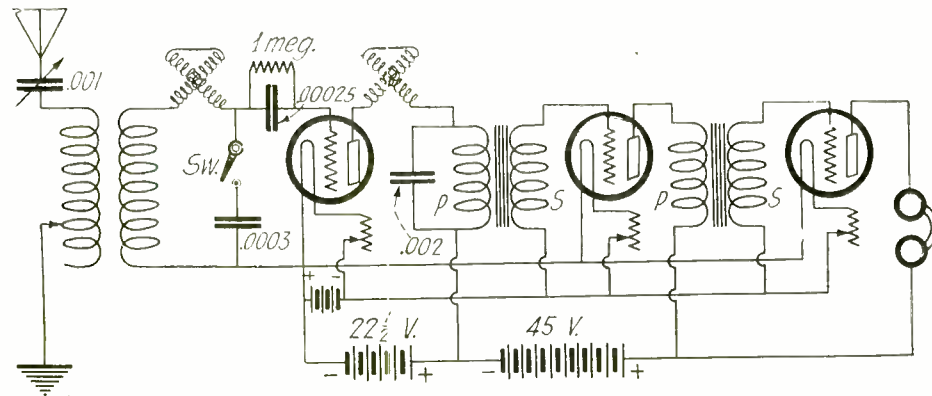

Q. 747. Here is the Familiar Short-Wave Regenerative Receiver. This Circuit is Hard to Beat for Efficient Results. A Small Fixed Condenser is Used in the Secondary Circuit for Higher Wave-Lengths.

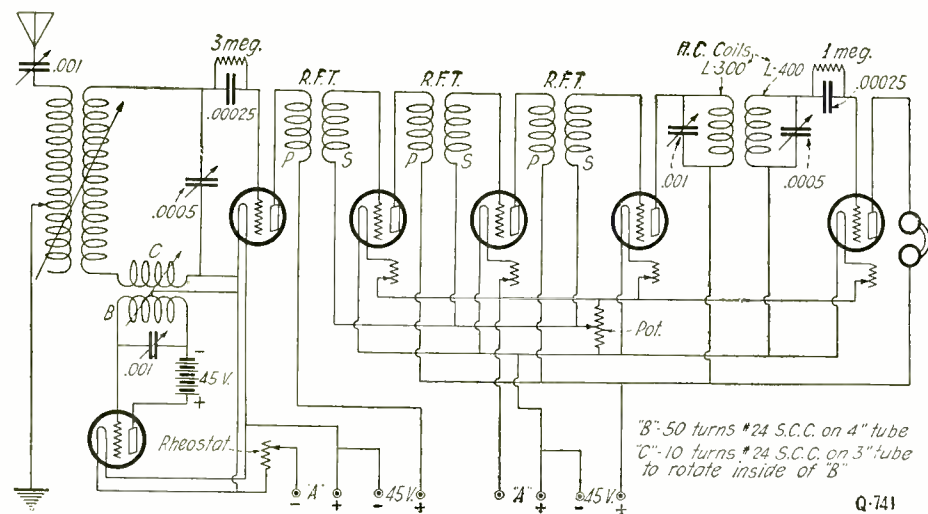

If You Want to Pull in Those Long-Distance Stations, This Is the Circuit You Should Use. A Six-Tube Super-Heterodyne, Using Transformer Coupled R.F. Amplification.

set compare with results obtained with detector and two stages of A. F.?

A. 2. The signals obtained with this circuit will be a little louder than with a detector and two stages of A. F., but the receiving range will be much greater with the reflex. This type of receiver usually takes a great deal of experimenting before maximum results are obtained.

**RESISTANCE OF MAGNET WIRE**

(746) Q. 1. Mr. Frank G. Snyder, Jr., Iowa City, Ia., writes:

Q. 1. Will you please publish a list of the various sizes of wire from No. 12 up, giving the number of ohms per foot?

A. 1. It is not practicable to give the number of ohms per foot, as the resistance would be too small for the larger sizes. Following is a list of the different sizes of wire, showing the number of ohms per 1,000 ft.

| Ohms per 1,000 ft. |       | Ohms per 1,000 ft. |       |
|--------------------|-------|--------------------|-------|
| B. & S.            |       | B. & S.            |       |
| No. 12             | 1,580 | No. 27             | 51.3  |
| 13                 | 1,995 | 28                 | 64.8  |
| 14                 | 2,504 | 29                 | 81.6  |
| 15                 | 3,172 | 30                 | 103.  |
| 16                 | 4,001 | 31                 | 130.  |
| 17                 | 5,04  | 32                 | 164.  |
| 18                 | 6,36  | 33                 | 206.  |
| 19                 | 8,25  | 34                 | 260.  |
| 20                 | 10,12 | 35                 | 328.  |
| 21                 | 12,76 | 36                 | 414.  |
| 22                 | 16,25 | 37                 | 523.  |
| 23                 | 20,30 | 38                 | 660.  |
| 24                 | 25,60 | 39                 | 832.  |
| 25                 | 32,2  | 40                 | 1049. |
| 26                 | 40,7  |                    |       |

**THREE-CIRCUIT TUNER**

(747) Mr. R. N. Adler, Ellwood City, Pa., requests:

Q. 1. Please publish a three-tube circuit which will be very selective and sensitive. I have one variocoupler and two variometers.

A. 1. This hook-up appears in these columns. A small fixed condenser can be shunted across

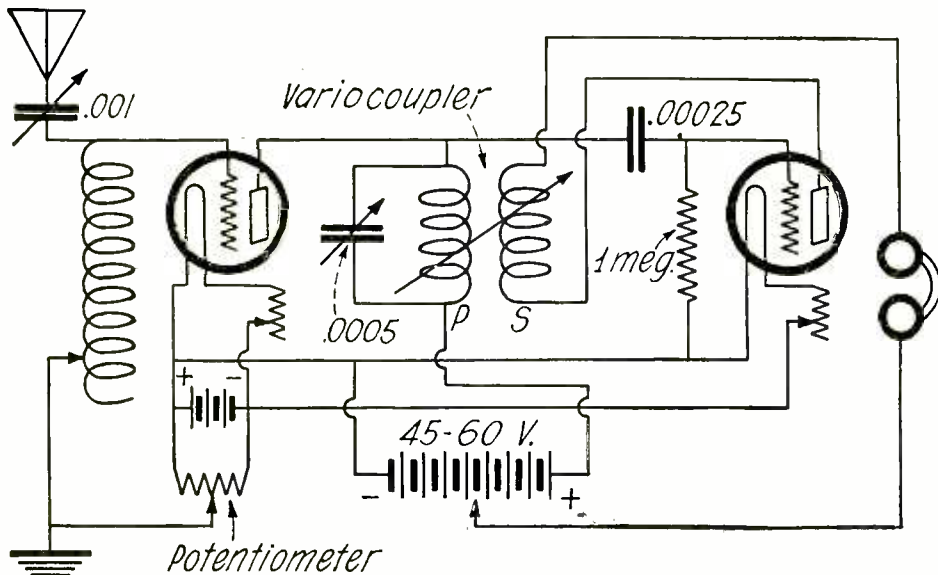

Q. 751. One Stage of Tuned Radio Frequency Amplification Can Be Used in a Regenerative Receiver By Following This Circuit.

eliminate this interference. You might try erecting a single wire, about 3' from and parallel to your present antenna, and connecting it directly to the ground. It might be of help to ground your receiving antenna at the far end, through an iron core choke coil of about one henry.

**SIMPLE PHONE TRANSMITTER**

(749) Mr. Geo. Von Behren, Burlington, Ia., writes:

Q. 1. Please publish a phone and C. W. circuit which uses one hard tube.

A. 1. This circuit appears on these pages. A D. P. D. T. switch is used so that either voice or key can be used.

**NEUTRODYNE QUERIES**

(750) Mr. W. F. Myers, Galion, Ohio, wants to know:

Q. 1. What are the capacities of the various condensers which are used in the Neutrodyne receiver shown in the May issue?

A. 1. All of the variable condensers across the secondaries of the transformers are .0005 mfd. capacity. The condenser across the phones may be .001 or .002. The grid condenser is .00025. The neutralizing condensers shown as K and K1 are of special construction. They consist of brass tubes about 2 3/4" long, so arranged as to slide over the two insulated wires connecting each grid. These grid wires should approach each other to a distance of 3/4 of an inch.

Q. 2. What kind of transformers would be best in this receiver—iron or air core?

A. 2. Transformers of special construction are used in this receiver. They are constructed as follows: The primary consists of 13 turns of No. 24 S.C.C. wire, wound on a tube 3" long and 3/4" in diameter. The secondary consists of 55 turns of the same size wire, wound

the secondary of the coupler and grid variometer for the higher broadcast wave-lengths, by means of the switch shown. If the primary has not sufficient inductance, the variable condenser in the antenna circuit can be shunted across the primary to increase the wave-length.

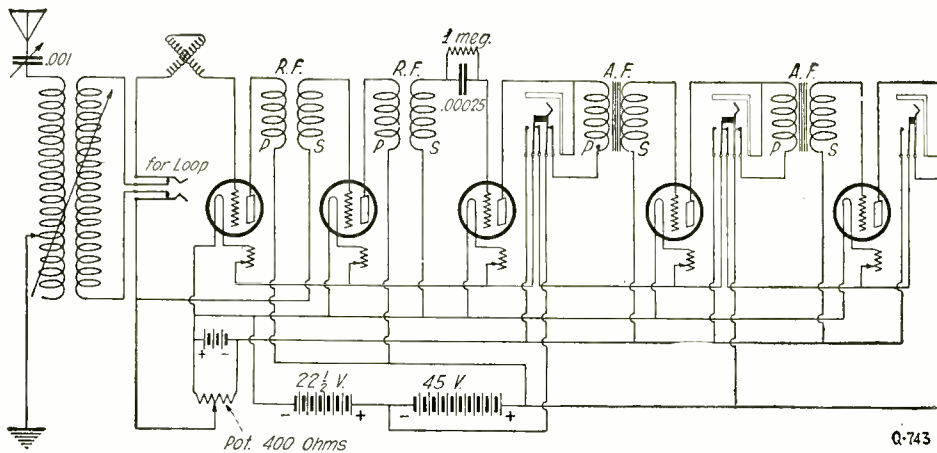

This Circuit Will Give Very Good Results, If Correctly Handled. Two Stages of Radio and Two Stages of Audio Frequency Amplification Are Shown.

**X-RAY INTERFERENCE**

(748) Mr. Edw. L. Wissmiller, Caro, Mich., wants to know:

Q. 1. Please publish a way to eliminate the interference caused by X-Ray machines. There are three of these machines near us and reception is impossible while they are in operation.

A. 1. There is very little that can be done to

on a tube 3" long and 3/4" in diameter. The primary should be inserted inside of the secondary and should fit snugly. When connecting this transformer in the circuit the secondary leads should be reversed, for best results.

Q. 3. Can a variocoupler be used for tuning in this set?

A. 3. A variocoupler can be used for tuning if desired, although good results are obtained with one of the special transformers in this position. If a transformer is used, no condenser is needed in the antenna circuit.

**REGENERATION WITH TUNED R. F.**

(751) Mr. Chas. Robert, Chicago, Ill., requests:

Q. 1. Kindly publish a diagram of a one-stage tuned R. F. receiver, using regeneration.

A. 1. This hook-up will be found on these pages. The primary of a variocoupler is used for the tuned impedance and the secondary is connected in the plate circuit of the detector, for regeneration. If only the broadcast wave-lengths are desired, 40 turns will be sufficient on the primary.

**WAVE TRAP**

(752) Mr. John Nicheron Spencer, N. D., requests:

Q. 1. Please publish instructions for constructing a wave trap.

A. 1. A wave trap usually consists of a coil of a certain size shunted by a variable condenser, and inserted in the antenna circuit of the tuner. This may consist of 50 turns of No. 24 S. C. C. wire, wound on a tube 3" in diameter. This can be shunted by a condenser of .0005 mfd.

Q. 2. Is enameled wire just as good as D.C.C. wire to wind a coupler with?

A. 2. Just as good results will be had with enameled wire, when used for this purpose.

(Continued on page 334)

# Gould UNIPOWER Battery

—a permanent radio unit power plant

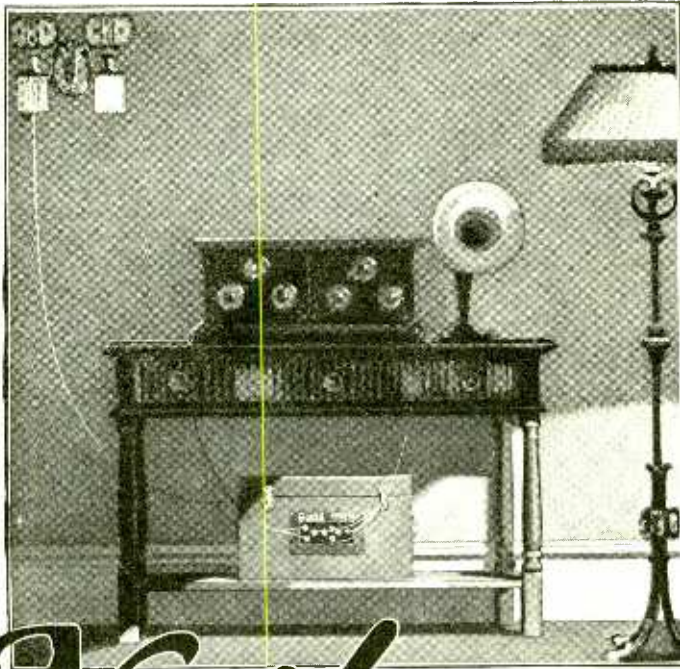

*Now!*

Now you can operate your radio set and charge your "A" Battery *at the same time.*

The Gould Unipower Battery, when hooked up to your set, gives you power from your house lighting circuit and the battery combined—or from the battery alone. "Just hook it to your lamp socket."

The only wires necessary are from your electric-light socket to Unipower, and "A" and "B" wires from Unipower to your set.

This extraordinary new development in power for radio sets gives you—

- 1—Years of constant, uninterrupted service with
- 2—The ultimate mile of distance, plus
- 3—Noiseless operation and finer tone quality
- 4—Without the bother of battery renewals or "sending out for recharging."

If your dealer hasn't yet stocked Gould Unipower Batteries send the coupon below direct to us for complete information.

**Gould Storage Battery Co.**  
30 East 42nd St., New York, N. Y.  
*Works: Depew, N. Y.*

**"Just hook it to your lamp socket"**

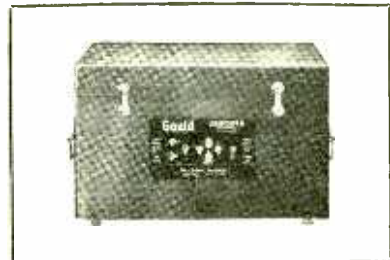

Gould Combination Unipower Battery—to operate both "A" and "B" circuits—\$45 to \$120, according to set. Send coupon for information.

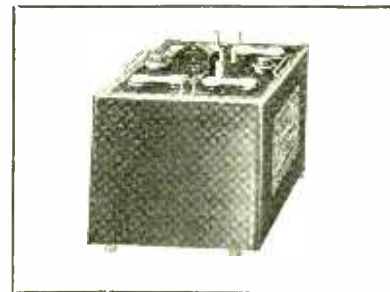

Gould Unipower "A" Battery—\$18 to \$40, according to set. Send coupon for information.

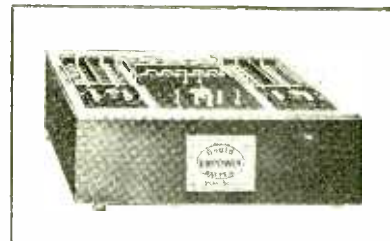

Gould Unipower "B" Battery. \$32 to \$82, according to set. Send coupon for information.



GOULD STORAGE BATTERY CO.,  
30 East 42nd St., New York

Please send me prices and complete information regarding Gould Unipower Batteries.

Name of radio set..... Is current A.C. or D.C. ....

Number of tubes..... If A.C. Current, what cycle.....

Trade name of tubes..... Voltage of "A" Battery.....

Voltage of house current..... Voltage of "B" Battery.....

(Fill in above information and write your name and address, together with name of your radio dealer, in margin below.)

# FRESHMAN RESISTANCE LEAKS

The largest and most Complete line in the World

They are unconditionally guaranteed to be scientifically correct, mechanically perfect and built for unusual durability.



Every tube and every circuit requires a different leak resistance. You do not know what value is necessary until your circuit is tested. Freshman Variable Resistance leaks give an unbroken range of 180 degrees from zero to five megohms.

Base Mounting Type with either .00025 or .0005 Freshman Condenser ..... **\$1.00**  
Without Condenser ..... 75c.



**PANEL MOUNTING**  
FRESHMAN VARIABLE RESISTANCE LEAKS will enable you to get stations you have never heard before. Can be mounted on any panel in a few seconds. The latest and most essential part of an efficient tube set.

With either .00025 or .0005 Freshman Condenser ..... **\$1.00**  
Without Condenser ..... 75c.



**FRESHMAN "FIX-O"**  
FIXED RESISTANCE LEAK COMBINATION — IN ONE

Freshman Condenser .00025 } Price Complete  
Leak Mounting } **65c.**  
Freshman Resistance Leak }  
Safe-T Handle }



**FRESHMAN FIXED RESISTANCE LEAK** with SAFE-T handle

The only Resistance Leak using no carbon, graphite or lamp black. Guaranteed to remain permanently constant.

Furnished in any value of Resistance from 1/4 Megohm up ..... **30c.**



**FRESHMAN NOISELESS**  
TESTED MICA CONDENSER and LEAK MOUNTING

The Freshman Condenser is so designed that constant equal pressure is exerted over the entire area of the condenser plates and the mounting is part of the condenser itself, which makes this new product the only True and Perfect Leak Mounting on the market.

Combination Condenser .00025 and Leak Mounting ..... **40c**

All Freshman Products at your dealers—otherwise send purchase price and you will be supplied without further charge. Also ask your dealer for our free diagrams of the Neutrodyne, Flewelling and Kaufman Circuits.

**Chas. Freshman Co. Inc.**  
Radio Condenser Products  
106 SEVENTH AVE. NEW YORK

## Facts About DX Crystal Reception

(Continued from page 273)

nal, or about four times that of the assisted crystal signal.

The layout for the second series of experiments is shown in Fig. 3. In this case it was found that the two sets influenced each other much less. Tuning the outdoor aerial and crystal set increased the regenerative signal about 50 per cent. and the crystal signal could be increased some 30 per cent with the aid of the regenerative receiver and indoor aerial. When the latter was set into oscillation the beat note on either side of 455 meters could be heard in the crystal receiver very plainly.

In order to eliminate the possibility of false results owing to the placing of the two sets in the same room with a common ground, the tests were repeated with the crystal set at the far end of the indoor antenna, as shown in Fig. 4, and later with the tube set in this position. An assistant made the necessary adjustments at the other end. The results were practically the same, the reaction being only slightly less owing to the somewhat looser electrostatic coupling between the two systems. It was therefore established that the effect was one occurring between the aerials, so that it may, and undoubtedly does occur, between the antennae of listeners situated near each other, although the sets may be in different houses

to the antenna, and if the set is functioning properly this current will be detected and heard in the form of a signal. Similarly antenna 2 receives a voltage  $V_2$  through its capacity to earth  $C_4, C_5, C_6$ . But if the antennae are at all near each other, they will also have with respect to each other an appreciable distributed capacity  $C_7, C_8, C_9$ . Through this capacity radio frequency energy may be transferred from one antenna to the other. If the current  $I_1$  is large, and  $I_2$  is small, the antennae being tuned to the same wave-length, antenna 1 will exert a very appreciable effect on the other receiving system, but will not be noticeably affected by the action in the latter. Now, in the case of a regenerative receiver the antenna current is much greater than the current  $I_1$  originally received from the distant station, for the effect of regeneration is to greatly increase the voltages and currents in the grid circuit of the tube by reaction from the plate circuit. Thus we have an explanation for the facts experimentally noted in the above tests.

When the regenerative set is in a state of oscillation, and it must be remembered that a great many DX records are made with zero beat heterodyne reception, it may have still another effect on nearby crystal receivers by radiating oscillations tending

to make the crystal detector more sensitive than in its normal, unassisted condition. This phenomenon was noted by Mr. Carl Ort eleven years ago, and described by him in a discussion on a paper by Mr. Edwin H. Armstrong presented before the Institute of Radio Engineers.\* Ort wrote, "It may be of interest to describe some experiments which I began in December, 1912, in a small town in Austria. At the time I was carrying on radiophone experiments, using a small Poulsen arc as a transmitting source. One day it happened that I received not only the speech from my arc station but also the noon

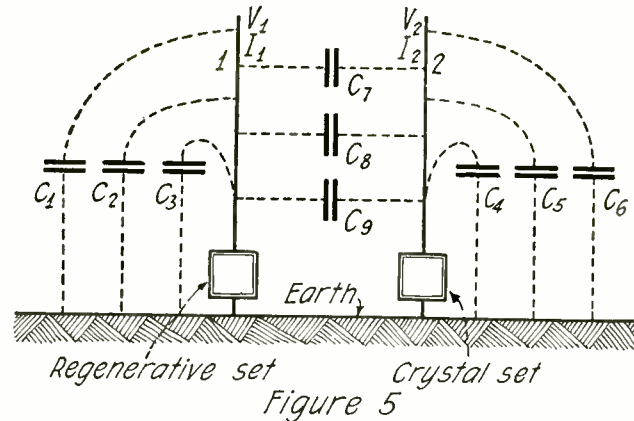

The Effective Capacity Existing Between Two Adjacent Aerials is Sufficient for the Transference of Radio Frequency Energy from One to the Other and, as Well, Through the Capacity Between Each Aerial and the Earth.

and the listeners quite unaware of each other's existence.

The tests were also repeated with weak signals, although of course the theory holds for any strength of signal. WBAN, a low power station in Paterson, N. J., on a wavelength of about 320 meters, was used for this experiment, the receivers being in New York City. WBAN was just audible on crystal with outdoor antenna. When the indoor antenna was tuned with the regenerative set to WBAN's wave a comfortably understandable signal was received thereon, and simultaneously there was a marked increase in the crystal signal to about four times its unassisted strength. The ratio was greater than on WJZ under similar conditions, which was probably due to the inherently greater amplifying capacity of a regenerative system on weak signals.

The explanation of these effects may be seen from Fig. 5, which represents two aerials, 1 and 2, near each other, 1 feeding a regenerative set, 2 feeding a crystal set. Antenna 1 has a certain distributed capacity to earth along its length, represented in the figure by the separate capacities  $C_1, C_2, C_3$ . By virtue of this capacity a certain voltage, represented by  $V_1$ , is induced on the antenna by a passing electromagnetic wave. This will cause a current  $I_1$  to flow through the antenna inductance of the set connected

time signals of the German Post Office station at Norddeich. The latter station was distant from my home about 380 miles (600 km.), the entire distance being over mountainous land. I was impressed by the great distance over which I was receiving with my small antenna, this being about 30 feet (9m.) high and about 90 feet (27m.) long. Furthermore, I noticed that the tone of the signals received with a crystal detector was no longer musical but resembled that obtained when a tinker was used. Later I investigated the latter phenomenon, applying sustained oscillations directly to the detector, and found that the amplification was due to the increase in sensitiveness of the detector. Every integrating (rectifying) detector showed this characteristic. I found that the amplification could be obtained with any frequency not audible to the human ear. The limit of amplification was determined by the maximum impressed voltage of sustained radio frequency at which the detector burned out. I was able to obtain amplifications of about 20-fold. . . . The same amplifying

\* See Armstrong: "A Study of Heterodyne Amplification by the Electron Relay," Proceedings of the Institute of Radio Engineers, Vol. 5, No. 2, April, 1917, and discussion following.

# DELTA



## GOLD-STRIPE RADIO HEAD SETS

"GUARANTEED ABSOLUTELY EQUAL OR SUPERIOR TO  
OTHER STANDARD MAKES AT MUCH HIGHER PRICES"

No. 500—2200 Ohm—\$6. No. 501—3200 Ohm—\$6.50

*Dealers and Jobbers—Write or Wire TODAY for Discounts*

**DELTA ELECTRIC CO.**  
AN INSTITUTION OF TWELVE YEARS' STANDING  
MARION, INDIANA

# GOOD RECEPTION EASY—

SUMMER OR WINTER!

## —If You Own a LEFAX Radio Handbook.

The man who owns a Lefax Radio Handbook gets good results from his set at all seasons of the year. Difficulties disappear readily. He can take instant advantage of every new development to improve his set and perfect reception—because Lefax Radio Handbook keeps pace with the new developments.

### The ONE Best Book on Radio

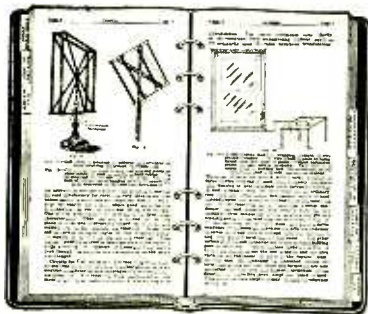

## LEFAX Never Grows Old!

Lefax Radio Handbook is loose-leaf and every month additional pages are sent out covering the new developments. These pages fit the handbook and may be inserted in appropriate places in the handbook thus keeping it *perpetually up-to-date!* Written by the two chiefs of U. S. Bureau of Standards Radio Laboratory (Dr. J. H. Dellinger, and Mr. L. E. Whittemore). Get your copy now. Price \$3.50 including one year of the service which keeps it up-to-date.

**LEFAX, Incorporated**  
147 So. Ninth St., Phila., Pa.

effect can be used at equal frequency for radio telephony." In Ort's last sentence we have, no doubt, the outline of a method of distance reception frequently and unconsciously used today.

The upshot of all this is that in any congested neighborhood, using the term in the radio sense, a distance record made on a crystal receiver is worthless unless evidence is presented that no nearby regenerative receiver was picking up the same distant station at the same time. The probability in any such case is that the crystal receiver was merely being tuned to the amplified antenna currents of some tube set on the same block. If one hears heterodyne squeals on a crystal receiver that is immediate evidence that a regenerative receiver is in action nearby and distant signals are apt to be relayed through it to the insensitive crystal set. While DX work on a crystal is possible and has actually been accomplished under conditions where assistance from tube receivers was out of the question, such bona fide DX crystal reception is rare, and most of the cases reported should be thrown out of court.

### Electrons, Electric Waves and Wireless Telephony

(Continued from page 267)

by speech being made to it (see Figs. 103 and 104). The method, however, is not very successful unless a certain supplementary steady voltage is applied by a battery in the plate circuit of the generating valve. The reason for the imperfection is that the transformer in connection with the microphone takes a little time to build up the voltage in the plate circuit of the valve which is necessary to set up oscillations, and there is therefore a want of response unless there is a

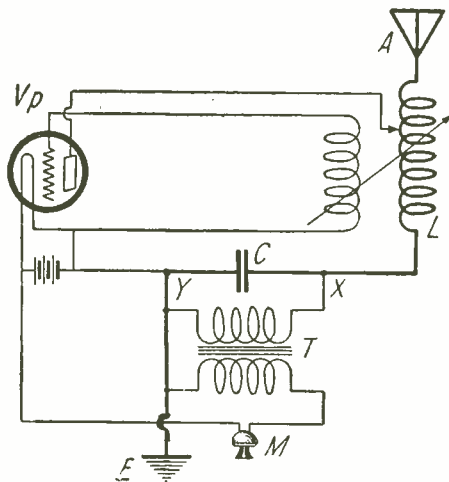

Fig. 103. A Type of Quiescent Aerial With a Valve Transmitter in Which the Microphone M Supplies the Plate Voltage in the Act of Speaking.

certain minimum of constantly maintained oscillations in the aerial, and the employment of these permanent oscillations defeats the very thing that it is desired to achieve, viz., the immunity of the receiver from the effect of the transmitter. We cannot, therefore, say that, as far as the confined space of airplanes is concerned, the problem of duplex telephony has been completely solved. As far as ground stations are concerned, it is worthy of notice that for not very great ranges with no very great differences in the wave-lengths, for example, two wave-lengths of 110 and 113 meters, and the transmitting and receiving stations only 100 yards apart, it has been found possible to conduct good duplex telephony.

### DIRECTIONAL SHORT-WAVE WIRELESS TELEPHONY

Another question of great practical interest in connection with wireless telephony is the employment of very short electric carrier waves of a wave-length of only 12 or 15 meters, and of reflecting mirrors to make a beam of electric radiation like an elec-

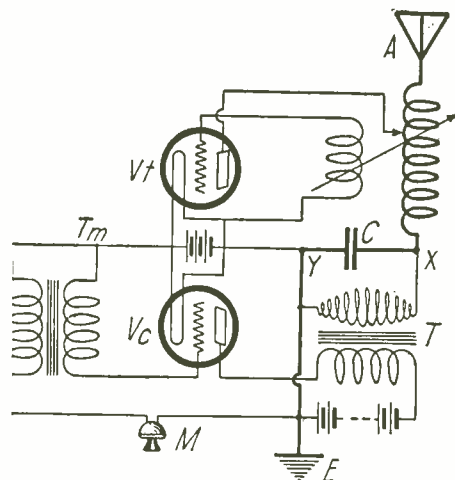

Fig. 104. A Type of Quiescent Aerial with a Valve Transmitter. The Microphone M Controls the Supply of Plate Voltage in the Transmitting Valve V.

tric searchlight. This "wireless beam" limits the lateral spread of the waves so that it conduces to privacy of speech. We have already explained in the section dealing with Hertzian waves that these waves can be reflected like rays of light from suitable surfaces.

In the case of an electric searchlight the arc lamp is placed in the focus of a parabolic silvered glass mirror, and this reflects all the rays falling on it in a direction parallel to the axis of the parabola (see Fig. 105). In the same manner, if we bend a large sheet of metal round two formers of wood so as to make a parabolic cylindrical mirror, and place a Hertzian linear oscillator on the focal line of the mirror, then, provided the dimensions of the mirror are not small compared with the wave-length, we shall project a beam of electric radiation, or of Hertzian waves, parallel to the axis of the mirror.

Experiments of this kind were made many years ago by Hertz and other physicists, and in the early days of wireless telegraphy Senatore Marconi employed parabolic mirrors in the initial attempts to use Hertzian waves as a means of signalling.

It is not, however, very easy to produce continuous electro-magnetic waves for the purposes of wireless telephony of wave-length much shorter than 10 to 15 meters. It is essential then that the dimensions of the mirror should be something of the order of 20 to 30 meters. If mirrors of solid metal were employed, these would not only be heavy to move, but would offer such surface to the wind that they would be dangerous to erect. It has been found, however, that if a number of wires are stretched parallel to each other on a frame, and at a small distance apart, this grid will reflect electric waves if the electric force in

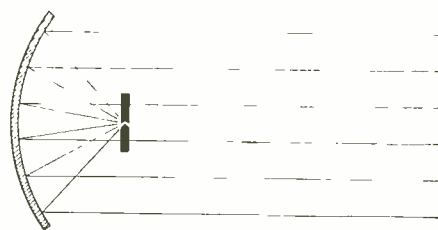
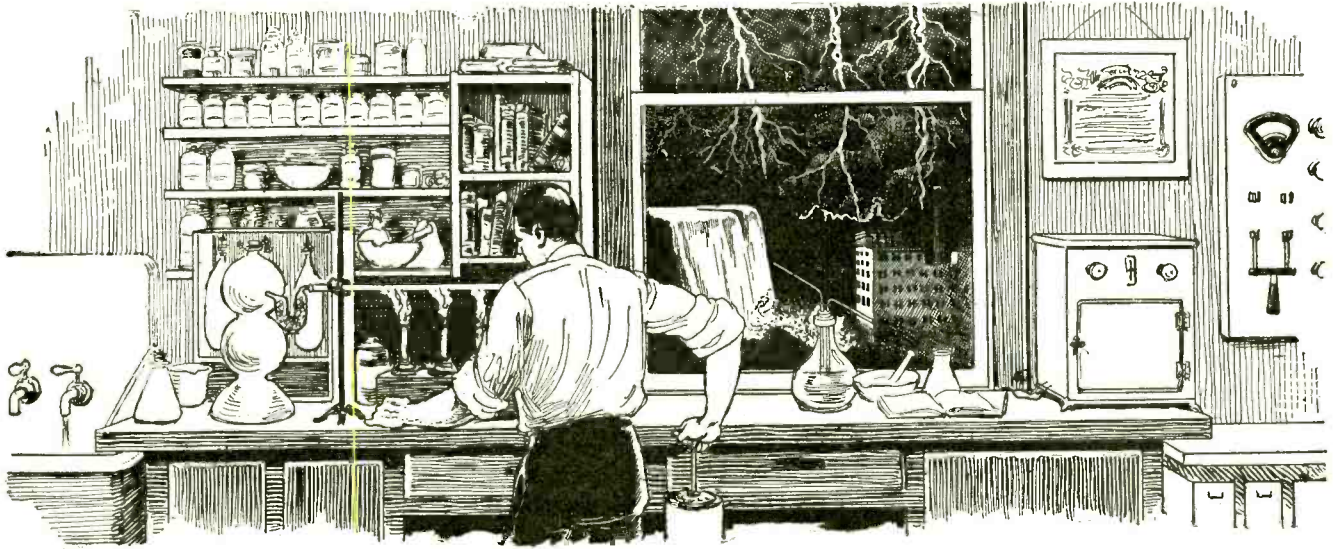

Fig. 105. A Parabolic Cylindrical Mirror, with a Hertzian Linear Oscillator on the Focal Line, Would Project Electric Waves Parallel to the Axis of the Mirror.



# When the Chemist Harnessed the Thunder-bolt!



**M**AN and beast react with electric speed to a warning of danger, if the alarm is immediate and personal. Self-preservation is the first law of Nature. Yet subtle perils far more disastrous than any we expect to meet lurk in the shadow of our fancied security. They are the dreaded ogres of Famine and Disease.

A few years ago the world faced a famine more terrible than any in history. Nitrates, the most essential materials for enriching the soil, were being rapidly exhausted, and universal starvation seemed inevitable. Everyone knows that plants must feed, and if the ground is not replenished with the chemicals they have consumed, vegetation will eventually die out. Nature's way of making up the deficit is too slow for our concentrated population, and farmers have resorted to artificial fertilizers for ages. Europeans, always more receptive to the teachings of Chemistry than we, raise more than twice as much grain per acre as Americans, owing to their greater use of fertilizing chemicals.

The principal substance used for this purpose is sodium nitrate, better known as Chile saltpetre, because of the large deposits of it in that country. Millions of tons of this precious chemical were being mined annually, for vast quantities are consumed in making explosives and in other industries, besides that required for agriculture. Chile kept getting richer, but her nitrate beds got continually poorer until their inevitable exhaustion became a grisly prospect. *And there was no other source of supply!*

It was here that electro-chemists stepped in and devised a way of making nitrates from the air! They stole a trick from Nature, using an artificial bolt of lightning, the electric arc, to change the nitrogen and oxygen into nitric acid. This is indeed what happens during a thunder-storm, though to a very slight extent. Other methods followed, and thanks to Chemistry the air-made nitrates can now be sold for less than the saltpetre of Chile. Better still, the supply is unlimited.

Today we are confronted with similar crises. There are impending shortages of other important raw materials. Yet so great is the general confidence in chemistry to solve such problems, little anxiety is felt. A wealth of opportunity awaits the chemist of the present, particularly in the fascinating field of Electro-chemistry. In many industries there are hundreds of chemists employed by a single company. Thousands of concerns have chemists supervising the quality of their output and of the materials they buy. In countless capacities a knowledge of Chemistry is essential.

## You Can Learn Chemistry at Home Dr. T. O'Connor Sloane Will Teach You

Dr. Sloane, Educational Director of the Chemical Institute of New York, is one of this country's foremost authorities on chemistry. He was formerly Treasurer of the American Chemical Society and is a practical chemist with many well-known achievements to his credit. Not only has Dr. Sloane taught chemistry for years, but he was for a long while engaged in commercial chemistry work.

The Chemical Institute of New York was originally founded to fill a long-felt need in the Educational field. Thousands of young men and young women, realizing the wonderful opportunities for the chemist produced by the recent war and the assumption by the United States of world leadership, were keenly anxious to enter this promising field. Many of these prospective students, however, were unable to give up their regular occupations to devote the necessary time to their training. Correspondence study at home was the only solution.

Dr. Sloane will teach you Chemistry in a practical and intensely interesting way. Our home study course written by Dr. Sloane himself is thorough, logical and remarkably fascinating. It is illustrated by so many experiments that are performed right from the start that anyone, no matter how little education he may have, can thoroughly understand every lesson. Dr. Sloane teaches you in your own home with the same individual and painstaking care with which he has already taught thousands in the class room.

### The Personal Help of Dr. Sloane

Dr. Sloane will personally examine and correct all of your examination papers, pointing out your mistakes and correcting them for you. He will, in addition, give you any individual help you might need in your studies. This personal training will be of inestimable value to you in your future career.

### Easy Monthly Payments

You can pay in small monthly amounts as you go along. The price of our course is very reasonable, and includes everything. There are no textbooks to buy extra, and the chemicals and apparatus used for experiments are supplied to the student *without additional charge*. Our plan places an education in chemistry within the reach of everyone.

### Experimental Equipment

**Given to Every Student Without Additional Charge**

We prepay even the shipping charges on the outfit. It comprises 42 pieces of apparatus and 17 chemicals and reagents. The fitted, heavy wooden case serves not only as a carrying case, but also as a laboratory accessory for performing experiments.

### Special 30-Day Offer

For a short period we are making a special offer that will be worth your while to take advantage of. Write for our free book, using the coupon below or simply a postal card. This will not obligate you in the least. Do not wait until tomorrow. Send the coupon now while you think of it, and let us tell you our story.

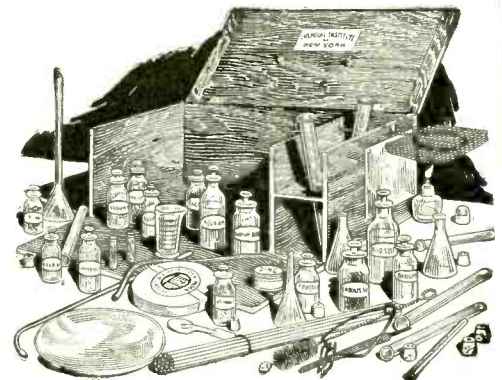

**CHEMICAL INSTITUTE OF NEW YORK, Inc.**

Home Extension Division 9,  
66-R—West Broadway, N. Y. City

Please send me at once without any obligation on my part, your free Book "Opportunities for Chemists," and full particulars about the Experimental Equipment furnished to every student. Also please tell me about your plan of payment and your special 30 day offer.

NAME .....

ADDRESS .....

CITY .....

STATE .....

R.N., 9-23

## Chemical Institute of New York, Inc.

Home Extension Division 9

66-R—West Broadway, New York City

## WHEN YOU BUILD A SET

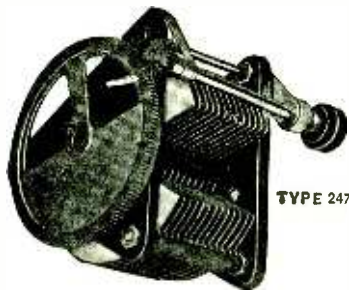

TYPE 247

## Here are the essentials

1. A quality Condenser—type 247—fitted with reduction gearing for fine capacity adjustment:

2. A Rheostat (or Potentiometer)—type 301—designed especially for UV-199 and 201A tubes:



TYPE 301

3. A UV-199 Tube Socket, ruggedly built of molded Bakelite, with phosphor bronze springs:

4. And the well known General Radio Co. Amplifying Transformer

giving maximum amplification without distortion.

All of these are guaranteed by the General Radio Company.

For dependability and results build your set around these essentials.



Type 299

Ask for Bulletin 914N. It contains our complete line of receiving equipment.

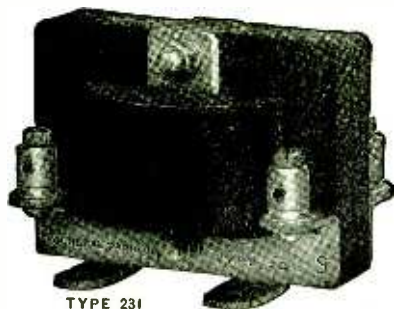

TYPE 231

## General Radio Co.

Manufacturers of  
Electrical and Radio Laboratory Apparatus  
Massachusetts Ave. and Windsor St.  
Cambridge, Massachusetts

5568

RADISCO RADIO PRODUCTS  
THE RADIO DISTRIBUTING COMPANY  
Newark, New Jersey

the wave is parallel to the direction of the wires.

Accordingly we can make a parabolic electric wave mirror which does not offer much surface to the wind as follows:—If we stretch a number of wires parallel to each other round the edge of two frames of parabolic form placed at a distance, the wires being held in such positions that they lie on a parabolic sectioned surface, and if we place parallel to these wires, and on the focal line of the parabolic surface, a Hertzian linear oscillator, we can project a wireless beam (see Fig. 106). It is easy to construct such skeleton parabolic reflectors of considerable dimensions, and since the wave-length of the waves radiated from a linear oscillator, or two rods placed in line, is about twice the total length of the rods, we only require a linear oscillator of about 25 feet or so in length to radiate electric waves of 15 meters wave-length.

Parabolic reflectors of this kind, with linear oscillators in their focal line, have been employed by Mr. C. S. Franklin in important experiments made for Marconi's Wireless Telegraph Company on directive short wave wireless telephony.\* The carrier wave was 15 meters in wave-length, and the oscillations were generated by a couple of power thermionic valves having a power consumption of 700 watts, having 4,000 volts on their plate circuits, producing a plate current of 175 milli-amperes. These valves created in a linear, or Hertzian oscillator, continuous oscillations of twenty million per second, and radiated a power of about 300 watts in the form of 15-meter electric waves. This oscillator was placed in the focal line of a skeleton wire parabolic mirror of about

30 meters aperture and a corresponding receiving aerial in the focal line of a similar reception mirror employed in reception by a usual amplifying valve detector.

After some preliminary and successful experiments at Carnarvon, a site was chosen at Hendon, and another at Frankley, near Birmingham, in February, 1921. These stations are 97 miles apart. With this plant telephonic speech was well conducted. Measurements indicated that the energy received with the directive mirrors up was about 200 times greater than when the mirrors were not used. Also it was found that very decided limitation to the lateral spread of the waves was obtained, so that places much outside the line of transmission could not overhear the speech.

It is quite practicable to employ still shorter wave-lengths of less energy. Carrier waves, even as short as four meters in length, have been used for such reflector transmission of telephonic speech over seven miles. It is expected that the employment of this "wireless beam" in nautical wireless telephony will prove to be of great utility in giving ships direction and location during fogs.

As these articles are intended to deal only with the elementary principles of the subject, and to be within the range of knowledge of the general reader or would-be amateur in wireless telephony, it is not possible or necessary to extend them to cover more highly technical matters, such as long distance wireless telephony or the influence on it of such factors as soil absorption or atmospheric disturbances, which are sufficiently treated in various textbooks.

(To be continued in the next issue)

## The First College Radio Club

(Continued from page 245)

May E. C. was married April 15th last. Draw conclusions and reply via Station C, 38 Weld Hall, at my expense.

(Signed) R. F. GOWEN.

The answer follows:

To R. F. Gowen,  
President and General Manager,  
5 Linden Street,  
Cambridge, Mass.

Hell.

(Signed) C. C. Pope.

Another very exciting message was the following:

To R. F. Gowen,  
President and General Manager,  
5 Linden Street,  
Cambridge, Mass.

Sta. C installed high power sending apparatus last night with P.G. (the Navy Station at the Charleston Navy Yard). Conversation with P.G. follows. P.G. was at the time listening to P.C.

(Portsmouth, N. H.)

(P.G. to P.C.) "Say, someone is sending on our wave. Do you hear him?"

(Sta. C. to P.G.) "P.G. P.G.—S.S. S.S. Can you get me?"

(P.G. to Sta. C.) "Who is it? I can just hear U."

(Sta. C. to P.G.) "I am Johnson of Cambridge. Thanks for the answer. S.S.S.—P.G.—O.K."

(P.G. to Sta. C.) "Don't mention it. G.B. G.B. B.K."

(P.G. to P.C.) "Do you hear him? It is a student at Harvard College. No, I guess you could not. I just get him. Well, I guess I will send out my weather report. K.A. K.A.—Snow followed by clearing late tonight. Saturday fair. Light, fresh N.W. winds."

(Signed) K. S. JOHNSON,  
Mangr. Sta. C.

Here's another decidedly important communication typical of what the Cambridge ether carried in those days.

To J. S. Galbraith,  
35 Weld Hall, Cambridge, Mass.

Greetings to our namer from Sta. A. Your cousin Victoria wires you through W.C.C. and Sta. A. that she presented her husband with a fine baby boy yesterday noon. Both father and child are doing well. She hopes that you may accomplish as great a feat some day. Sig. Victoria.

(Signed) R. F. GOWEN.

To President Gowen.

Sta. A., Cambridge, Mass.

Have just heard that the boy is named Phonepteros so he should make a good political orator. My feet are great anyhow, but I hope that some day I may perform a feat as great as the one you mention.

(Signed) J. S. GALBRAITH.

Undoubtedly the inevitable "Greetings by Wireless" message was also in existence and used at this time, though there is no distinct recollection of it and probably the most important message received by a Weld Phoneptero-graph Co. station was one dated Jan. 23, 1909, when Bob Morton, '11, picked up the following one night at Station A, then located on Cambridge Street.

To U. S. S. "Lebanon" off Cape Cod.

By order of Sec. of Navy.

Go to assistance of Italian steamer "Florida" having steamer "Republic" passengers on board. Exact locality not known. Probably trying to make Newport. Advise you to go through Sound and search between Gay Head and Montauk Point and from there to the S.W.

(Signed) WINSLOW.

This was one of the first catastrophies in which wireless showed its worth in saving many lives. History was made that night and wireless then established a place for itself from which the present day radio was born. This message also made history for the Weld Phoneptero-graph Co.

\* For a full description of these experiments the reader is referred to "The Wireless World and Radio Review," of May 20th, 1922, vol. X, p. 219, and the Paper read by Mr. C. S. Franklin before The Institution of Electrical Engineers, May 3rd, 1922.



# Use *Any* Tube with the Universal Bradleystat



### A Letter from an Ohio Radio Dealer

"The Bradleystat has met with our entire approval. We have made it regular equipment on all Westinghouse R.C sets sold by us and have installed many Bradleystats on Crosley and other receivers, with perfect satisfaction."

### Dealers

New counter cards, technical folders and other sales helps are ready for you, explaining the wonderful opportunities of the Universal Bradleystat. Be prepared to meet the demand of thousands of radio set users who are clamoring for the Universal Bradleystat.

Price, \$1.85

Parcel Post, 10c extra

**T**RY any tube—old, new or foreign—in your radio set. The new Universal Bradleystat with three terminals will give perfect filament control for any tube you may select. There is no need of tearing down your set to install a new rheostat whenever you change tubes. A simple change of connections gives you noiseless, stepless, perfect control.

Bring your set up-to-date by installing the Universal Bradleystat with three terminals. It is for sale by all radio dealers at the same price as the old Bradleystat, now used in several hundred thousand radio sets. Remember, the Universal Bradleystat is guaranteed to give satisfaction.

**Allen-Bradley Co.**

Electric Controlling Apparatus

287 Greenfield Avenue, Milwaukee, Wis.

Manufacturers of Graphite Compression Rheostats for Twenty Years

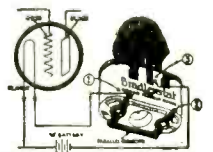

For 1/2 and 1 amp. tubes

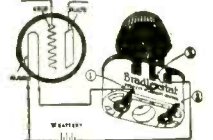

For 1/4 amp. tubes

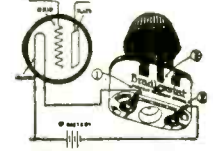

For .06 amp. tubes

# KC RADIO

## KUALITY SERVICE

Kilbourne & Clark Mfg. Co.  
Head Office and Works: Seattle

BRANCH OFFICES:  
Portland San Francisco Los Angeles  
New York City

For 10 years we have built radio apparatus for ships, shore stations, U. S. Navy, amateur and experimental use.

### OUR MERCHANDISING LINE

- |                |                   |
|----------------|-------------------|
| Receivers      | Plugs             |
| Amplifiers     | Jacks             |
| Head Phones    | Adapters          |
| Loud-Speakers  | Sockets           |
| Condensers     | Amp. Transformers |
| Rheostats      | Variometers       |
| Potentiometers | Variocouplers     |
| Switches       | C. W. Apparatus   |

COMPLETE LINE OF MOULDED PARTS

WATCH THIS SPACE FOR THE LATEST SPECIALTIES

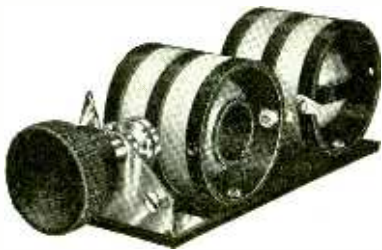

### CONTINUOUSLY VARIABLE RADIO FREQUENCY AMPLIFYING TRANSFORMER

Two Stage ..... \$10.00  
Single Stage ..... 5.50  
Range 150-550 Meters

CAN BE ACCURATELY TUNED TO ANY WAVE LENGTH BETWEEN THESE LIMITS

**New York Coil Company's**  
New Radio Frequency Transformers Are a Revelation  
Price \$4.00

Many Other New Devices. Literature Ready  
338 Pearl Street, New York City, N. Y.

## ROSE RADIO SUPPLY

Complete Stock—Both Sets and Parts—  
All Makes  
129 Camp Street New Orleans, La.  
Send 10c for latest catalog

## An Inductance Variometer---A Utility Radio Unit

(Continued from page 279)

be varied. However, the amplifier works very well as described.

### ADAPTED TO ARMSTRONG'S SINGLE TUBE SUPER-REGENERATIVE CIRCUIT

Fig. 7 illustrates the connections for a single tube "super," where a variometer is used in the plate circuit combined with the writer's novel features. The diagram is self-explanatory.

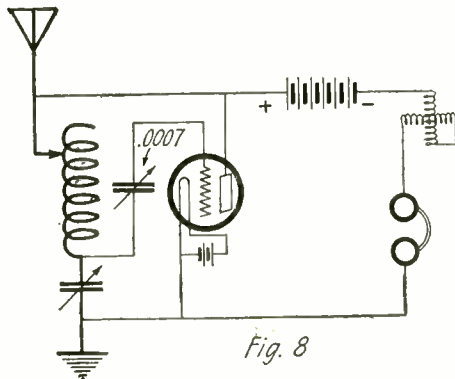

Fig. 8

The Inductance Variometer Improves the Operation of the Gibbon's Circuit, Allowing Good Reception on Short Waves. The Tuning Inductance Is a Portion of the Unit.

### ADAPTED TO GIBBONS' CIRCUIT

This circuit received quite some popularity some time ago among radio enthusiasts, but it does not prove very stable on short waves, refusing to oscillate on 200 meters very effectually. This has very easily been overcome by adapting the circuit to the writer's inductance-variometer. The improved and modified circuit is shown in Fig. 8.

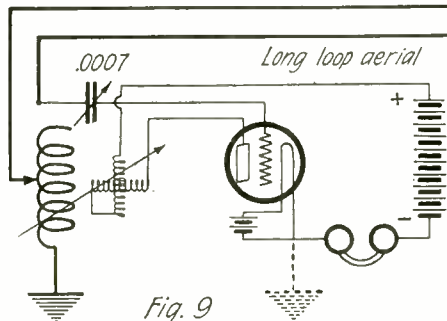

Fig. 9

A Modification of the Uni-Polar Circuit Used in Conjunction with a Loop Aerial. The Inductance Variometer Serves for Both Tuning and Regeneration.

### ADAPTED TO BUCHER'S OPEN-CIRCUIT OSCILLATORS

Several years ago Elmer E. Bucher, prominent radio and electrical engineer, developed a circuit wherein the highest po-

The Inductance Variometer Incorporated in a Circuit Having One Stage of Impedance Coupled Radio Frequency Amplification. The Tuning Inductance in the Antenna Circuit Is a Coil Having a Slider, or One Tapped at Intervals.

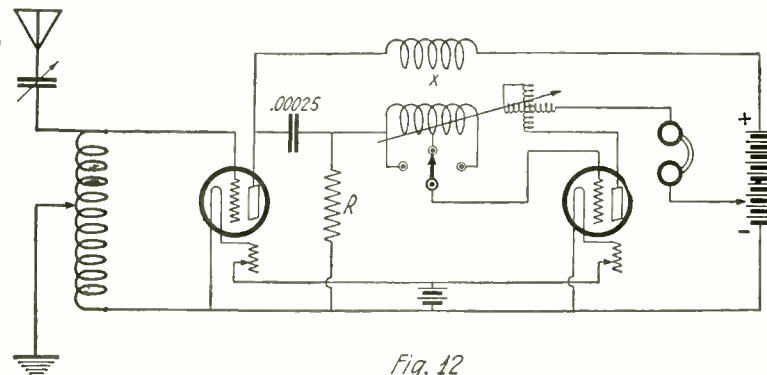

Fig. 12

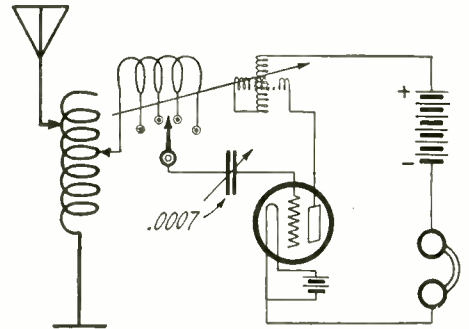

Fig. 10

The Unit Adapted to a Uni-Polar Circuit. This Arrangement Will Regenerate or Oscillate, Though There Is No Grid-Return Circuit.

tential obtainable from a given group of oscillations received is impressed on the grid. By adapting his circuit to the writer's inductance-variometer method, still further amplification will be had. The circuit is given in Figs. 9 and 10, modified.

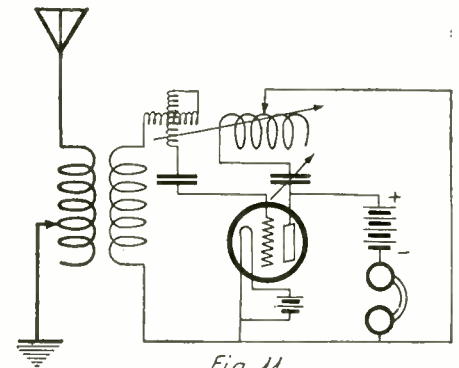

Fig. 11

The Inductance Variometer Works Well When Employed in Conjunction with the Weagant "X" Circuit. The Variocoupler Is Used as the Tuning Unit. Note that the Plate-Circuit Is Tuned.

### ADAPTED TO WEAGANT'S "X" CIRCUIT

In Fig. 11 is shown Weagant's "X" circuit improved by incorporating the inductance-variometer.

### PHILLIP N. EMMICH'S RADIO FREQUENCY CIRCUIT IMPROVED

In Fig. 12 is shown one step of radio frequency in conjunction with the writer's method of coupled grid and plate circuits. The choke coil at X consists of a small secondary of a spark coil. The resistance at R is an ordinary grid leak, preferably variable.

### CONCLUSION

This method can be incorporated in any circuit where regeneration is desired, the results being from two to five times better than with other conventional methods.



# Are you the man

*who will win one of the fifty prizes offered by ACME for the best results obtained with radio frequency this summer?*

**F**OR the best article setting forth how radio frequency has helped conquer summer static and other forms of interference (such as radiating receiving sets and spark transmitting stations) the Acme Apparatus Company will pay \$250.00 in cash. To the second best, \$150.00 and to the third best \$100.00 in cash. To the next 47 best articles this company will give prizes of different Acme Apparatus ranging from \$80 for Acme phones to \$5 for radio and audio frequency transformers.

The article must narrate the personal experiments and experiences of the writer, in securing distant stations, in avoiding interference and distortion, and in securing volume and clearness of reception. Wiring diagrams

showing the hook-ups used to secure the best results will add greatly to the value of the article. The articles must not exceed 500 words in length. Radio frequency transformers of any make or brand will be eligible. The contest starts June first and ends September thirtieth. All articles must be postmarked not later than October first.

In case of a tie, each tying contestant will receive the full amount of the prize. Everybody outside the Acme organization is eligible. Do not stay out of the contest for fear that you are not an "expert". A novice with natural mechanical or electrical ability may capture first prize. Send the coupon below or apply to any radio dealer to secure complete details, including list of judges and prizes.

**ACME**  
*for*  
**amplification**

ACME APPARATUS COMPANY  
 Cambridge, Mass.  
 Please send me detailed information on  
 Acme prize contest on radio frequency.

Name .....

Street .....

City .....

State .....

# A Triumph in Radio

## The Single Tube Radio Frequency Receiver

### Performs the Function of 2-Tubes

Only One Control  
Ideal Vacation Set  
All Wave Lengths

**\$10<sup>00</sup>** Without Tube

Including Two Interchangeable Induc-  
tance Coils for Wave Lengths ranging  
from 200 to 600 Meters

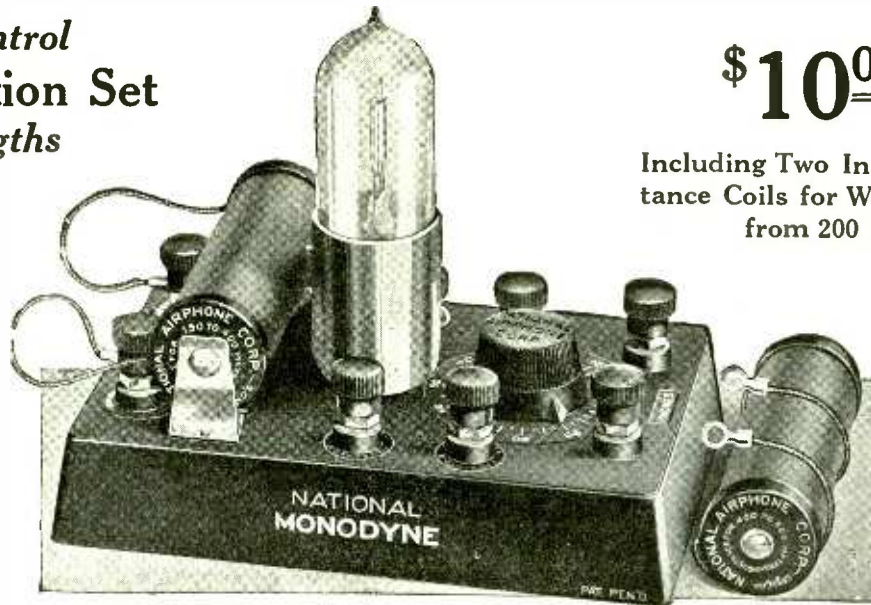

**1000 MILES ON THE MONODYNE**

Gentlemen: Having purchased your Monodyne set I was more than pleased over the results obtained from it. I think it is one of the best one-tube sets on the market today.

I have heard the following long distance stations—WDAF Kansas City, WDAP Chicago, WSB Atlanta, WOO Philadelphia, WGY Schenectady, WOC Davenport, and a Canadian station whose call letter I could not obtain.

Using hook-up No. 4 gives very selective tuning and volume. Your set cannot be praised too highly.

**WILLIAM BROWN**  
65 East 117th St., N. Y. C.

# NATIONAL MONODYNE

PAT. TRADE MARK PDG.

## TUBE SET

### MODEL GT-1

Entirely new circuit. The single tube performs the double function of radio frequency amplifier and detector.

Simplicity and Economy. One simple tuning control gives selectivity equal to sets costing hundreds of dollars.

The **MONODYNE** CIRCUIT is one of the most radical advances in radio engineering since the advent of the Armstrong Circuit. Parts heretofore considered essential are omitted and one simple tuning control gives a selectivity equal, if not superior, to that of sets costing hundreds of dollars. A child can operate it.

#### SIMPLICITY

The NATIONAL MONODYNE uses but one dry cell tube, preferably the WD-12 or any other standard dry cell tube, such as the UV-199 or C-299 types. Local broadcasting comes in astonishingly loud and clear, without distortion.

The tube socket is of a new design and most practical because it holds the tube with a positive grip on all four prongs for a depth of more than one-quarter of an inch.

The NATIONAL MONODYNE AIRPHONE will find especial favor with experimenters because of its adaptability in many different hook-ups, a thing not possible with any other low priced outfit.

#### LONG DISTANCE

In our New York laboratory tests, we repeatedly heard stations KYW at Chicago, WOC at Davenport, Iowa, and many others, quite loud and clear. This without resorting to any mode of amplification.

The NATIONAL MONODYNE is the most practical tube set made, and is complete in all details. It is only 6 1/2 inches long, 4 1/4 inches wide, and 2 3/4 inches high of durable, compact and rugged construction. The entire casing is moulded from hard rubber composition.

The NATIONAL MONODYNE has a receiving capacity and range of about 1500 miles. 75-foot aerial is recommended for best results.

**No more Hunting for stations. You know in advance at what point of the scale your favorite station is located—only the highest priced sets accomplish this.**

Dealers, Jobbers and Distributors—Send for Samples and Prices

#### SEND NO MONEY

National Airphone Corporation, R. N. 9  
18 Hudson Street, New York City, N. Y.

Gentlemen:

Please send me prepaid One (1) NATIONAL MONODYNE tube set, Model GT-1, for which I will pay the postman \$10.00.

NAME .....

STREET AND NO. ....

CITY ..... STATE .....

**NATIONAL AIRPHONE CORPORATION**

18 HUDSON ST. NEW YORK

# NATIONAL Interference Eliminator

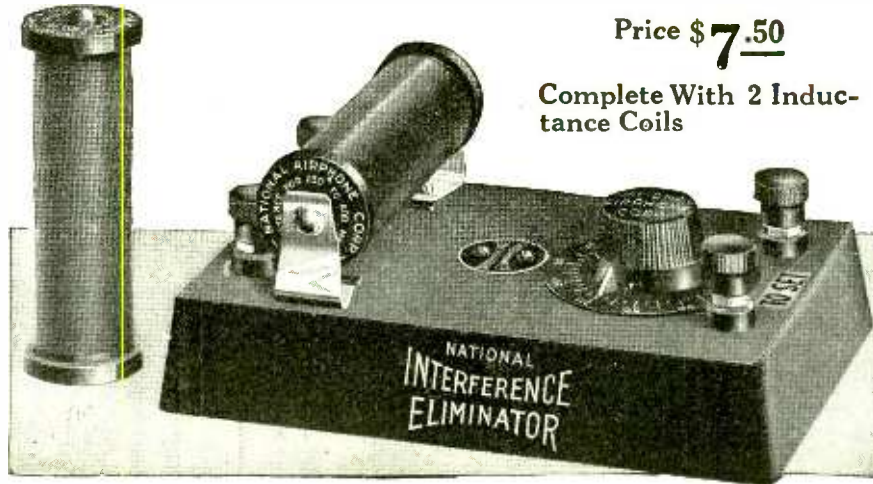

Price \$ 7.50

Complete With 2 Induc-  
tance Coils

Adds Selectiv-  
ity to your  
set.

Tunes out side  
waves or har-  
monics of pow-  
erful broadcast-  
ing stations.

Will make  
your set tune  
sharper.

Two coils go with  
instrument, one  
for short and  
another for long  
wave lengths.

The National Interference Eliminator can be used with all radio outfits no matter what make, tube or crystal. Will bring in stations you never heard before. Nothing else required with set as illustrated. Just connect it with two short wires to your outfit.

## A NATIONAL STANDARD INSTRUMENT OF MERIT AND RELIABILITY

Eliminates Broadcasting and Code-Signal Interference  
Can be used to increase or shorten Wave Lengths

AN ABSOLUTE NECESSITY TO CLEAR RECEPTION

## NATIONAL AIRPHONE "GOLD-GRAIN" DETECTORS

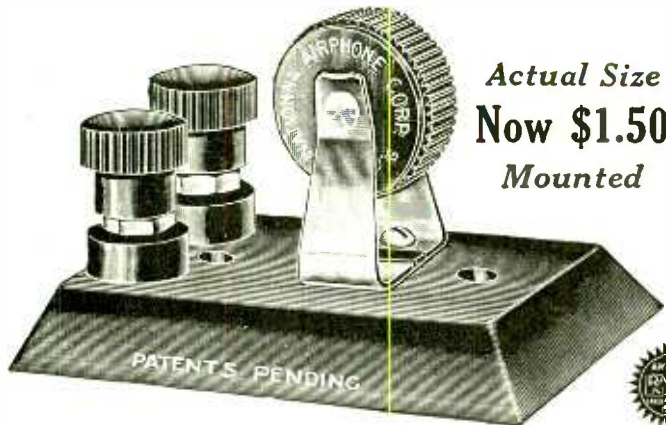

Actual Size  
Now \$1.50  
Mounted



After you have fussed with catwhiskers, springs, balls and adjustment handles, and after you have almost become a nervous wreck, hunting for "the elusive sensitive spot"—you will welcome with open arms our 100 per cent. GOLD-GRAIN DETECTOR.

This Detector is foolproof; has no catwhiskers; no springs, no balls, no adjusting handles; no fussing. The detector is Entirely enclosed in hard rubber composition cartridge, but it is NOT a fixed detector.

A special crystal is used, while contact elements are made of pure gold. There is always a multiplicity of contacts. The Detector is sealed hermetically. The contact with the crystal is always perfect.

This detector has been pronounced by experts as the greatest detector in existence. It reproduces voice, and music in natural color of tone, without distortion. You will be surprised at the wonderful results and satisfaction obtained with the "GOLD-GRAIN" Detector.



Now  
\$1.00



Actual Size  
FOR PANEL  
MOUNTING

## Most Practical for Reflex and Crystal Sets

Dealers, Jobbers and Distributors—Send for Samples and Prices

**NATIONAL  
AIRPHONE  
CORPORATION**  
18 HUDSON ST. NEW YORK

### SEND NO MONEY

National Airphone Corporation,  
18 Hudson Street, New York City, N. Y.

R. N. 9

Gentlemen:

Please send me the crossed  
articles, for which I will pay  
postman on delivery the adver-  
tised price.

One  Interference Eliminator  
One  Mounted Detector  
One  Panel Detector

NAME .....

STREET AND NO. ....

CITY ..... STATE .....



**makes perfect panels**

No other material known is so "professionally smart" as beautiful.

**bakelite-dilecto!!**

(A Laminated Phenolic Condensation Product)

Bakelite-Dilecto (xx grade) makes any home-made hook-up look like a "store set".

Finished a sleek, everlasting black. Astonishingly hard and tough; yet machinable. Highest dielectric strength.

Have your electrical dealer get B D X X cut to the exact size you require.

**The Continental Fibre Co.,  
Factory: Newark, Delaware.**

Dealer Service From:  
New York, 233 Broadway  
Chicago, 332 S. Michigan Ave.  
Pittsburgh, 301 Fifth Ave.  
San Francisco, 75 Fremont St.  
Seattle, 95 Connecticut St.  
Los Angeles, 411 S. Main St.

**WORKING KNOWLEDGE OF THE CODE AND RADIO LICENSE ALL IN ONE WEEK**

Notable Examples, Quick Success Free. Honor Roll 100 Beginners now Licensed. Reports, Learning Records, One Dime. Complete Method and Honor Roll \$2.00.

**BKUMA YRLSBUG**  
(Trade Mark)

**C. K. DODGE**

DEPT. N. MAMARONECK, N. Y.

**Detection**

(Continued from page 263)

is mechanically closed a thousand times a second, while with this system the circuit is electrically closed, so to speak, a thousand times a second by being brought into the resonant condition that frequently.

All these methods, though they may still be used to some extent to-day by experimenters, have slowly been giving way to a method which excels them in every possible way. This method is the HETERODYNE method of reception. The principle of the heterodyne is very old. Its application to radio is relatively modern, the originator of the system be-

acting at the same point, as when an echo meets the original sound wave. When these two wave motions are impressed on the same point the total effect produced is the sum of the two effects individually, hence will be the sum of the effect of both waves. But it is seen that at one point the wave motions are opposed to each other, and at another point they assist each other. Hence at the point where they oppose each other there will be a falling of the sound intensity which is heard faintly or not at all, or in the case of light there will be darkness. At the point where the wave motions assist each other there will be a rising in the sound intensity, or there will be a bright light. This falling and rising of intensity is called "beats" and is due to the interference of two waves.

**THE BEAT METHOD**

Now let us see what the application of this is to the reception of continuous radio waves. Suppose that we are able to impress two radio waves on a receiver, one of these waves having a frequency of 500,000 cycles per second and the other having a frequency of 499,000 cycles per second. Due to the fact that they are superimposed on each other they will interfere at some points opposing and nullifying each other, at other points assisting and reinforcing each other. The resultant wave of current which is produced has a number of zero points due to the fact that at these points the two waves opposed each other, and there are large current points due to the fact that at these points the two waves assisted each other. This rising and falling of current amplitude constitute the beats of the system. The opposition and assistance in beats takes place at a definite frequency, namely the difference between the two interfering frequencies. In this case the difference in the two frequencies is 1000 cycles per second. Hence when this resultant current wave is rectified the telephone current will have a frequency of 1000 cycles per second which will then be heard. It is therefore seen that by properly co-

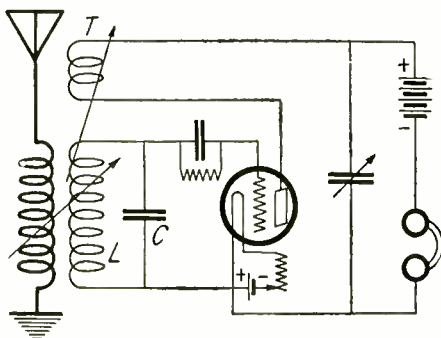

Fig. 7. A Simple Heterodyne Receiving Circuit of the Self-Heterodyne Type.

ing R. A. Fessenden, who described his method in 1907. The special importance of this system is due to the development of the vacuum tube oscillator which is used today exclusively in this method of reception.

**HETERODYNE RECEPTION**

The heterodyne system is based on an important principle of wave motion called "interference." This phenomenon of interference is present in the transmission of sound waves and light waves, and in fact in the transmission of any kind of wave motion. In the sphere of sound waves the reader has possibly heard of the so-called "whispering gallery" in which the ticking of a watch may be heard very loudly in some parts of the room and not at all in others. This is really due to separate phenomena assisting each other, one of which is the heterodyne effect. The sound waves from the ticking watch or a whisper are transmitted outward and are reflected from the walls of the room. This reflected sound is what is known as the "echo." At certain parts of the room the echo and the original sound wave meet and re-enforce each other, and the resultant sound which is heard is very loud. At other parts of the room the echo and original sound wave meet and oppose each other, when no sound is heard. A simple experiment illustrating this phenomenon is that of sounding two tuning forks whose frequencies of vibration differ by a small amount. A smooth uniform sound will not be heard. Instead the experimenter will hear a rising and falling note, loud and soft. A similar phenomenon occurs in the sphere of light. It can be so arranged that a beam of light and its reflection meet at some points. At these points it will be observed that there are alternate streaks of light and darkness.

These phenomena are due to "interference" of waves. Suppose that we have two wave motions, sound or light, whose frequencies of vibration differ by a small amount, and suppose that they both are

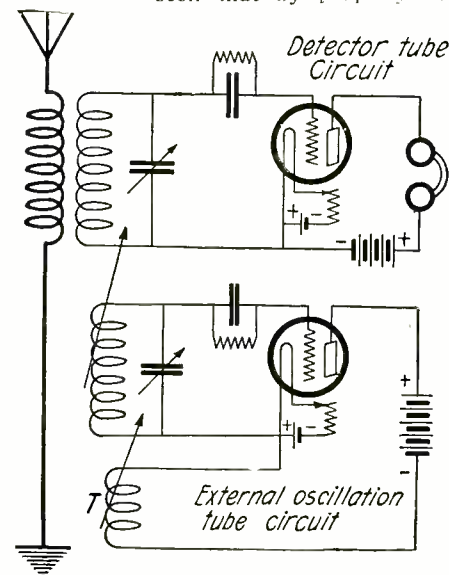

Fig. 8. A Heterodyne Receiving Circuit Employing an External Oscillator for Producing the Heterodyne Effect.

ordinating two different waves, and rectifying the resultant wave, a signal will be heard. The rectification of the resultant wave takes place in the manner



# NEW 25c BOOKS

## That Every Novice or Amateur Needs

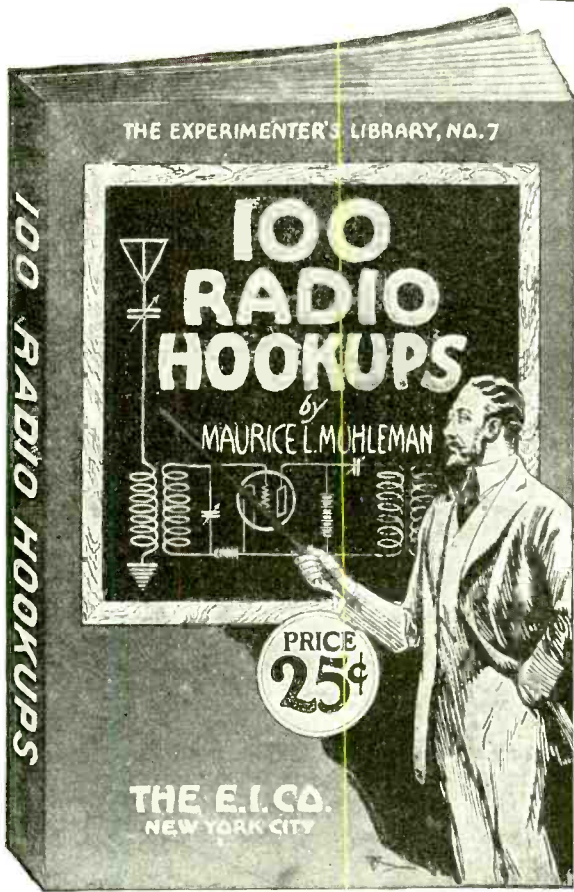

### 100 Radio Hook-ups

By M. L. MUHLEMAN

A book for both the novice and advanced radio amateur containing a varied selection of hook-ups from the simple crystal to the more elaborate circuits, with a circuit for every requirement. Crystal hook-ups, combined crystal with radio and audio frequency amplifiers, non-regenerative, and regenerative vacuum tube circuits with and without radio and audio amplifiers. Amplifier units, with straight jacks, filament and switching arrangements, power amplifiers, choke coil, resistance coupled and transformer coupled radio frequency amplifiers.

Includes all of the latest, one and multi-tube hook-ups including the numerous types of Reflex, super regenerative, super-Heterodyne, Neutrodyne, Reinartz, Flewelling, and Bishop. The values and constants of all apparatus employed in the hook-ups are given. A list of radio symbols is included, which are of material help to the reader in determining the meaning of the conventional hook-up diagrams. The text includes much helpful information.

52 Pages—Two-Color Cover ..... **25c.**

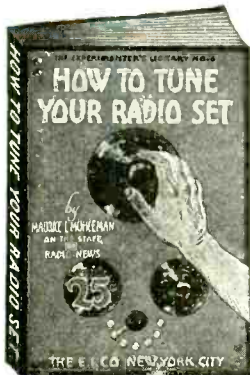

This book covers in comprehensive form, the fundamental principles of tuning. The characteristics of radio waves are fully described and illustrated. Illustrations are used so that the non-technical reader can easily understand the identical actions as applied to radio. Several chapters are devoted to the use and functions of all radio apparatus. The book describes how to tune such sets as the Reinartz, Flewelling, Neutrodyne, radio frequency amplifier receivers and other.

52 pages, 25 Illustrations  
Prepaid ..... **25c**

A non-technical book for the beginner. Gives complete constructional data on the building of a complete Crystal Detector Set, Tuning Coil, Loose Coupler and a Single Audion Tube Set with Amplifying Units. It furnishes all dimensions and working drawings of every part that must be constructed by the amateur. Written in plain, simple language that anyone can understand. The opening chapter gives a complete description of the theory of radio and tells what it's all about, teaching the principles of wireless so that the constructor knows what he is doing.

48 Pages, 26 Illustrations  
Bound in Beautiful Two-Color Cover. Size, 5½ x 7½ in. Prepaid ..... **25c**

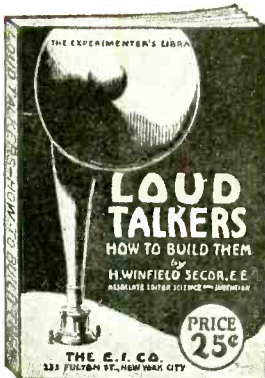
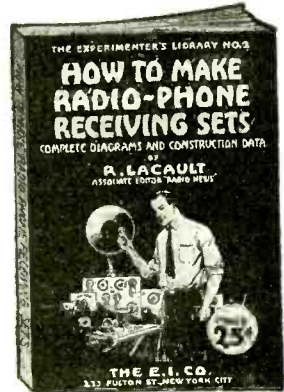

This book describes and gives complete data for building two distinct types of loud talkers. One chapter deals with improvised loud talkers, and gives complete instructions on how to build suitable horns for use in loud receivers of the Baldwin and other types. In preparing these designs, the point has been constantly kept in mind to use the simplest parts possible, so that anyone can build a successful loud talker, equivalent to the commercial types, costing \$40.00 or more.

48 pages, Profusely Illustrated  
Prepaid ..... **25c**

This book is for the more advanced amateur, showing the construction of the Radio Frequency Amplifying Transformer and giving complete constructional data. It shows the application of Radio Frequency to amplifying units that the amateur may already possess and gives 15 hook-ups showing practically every use Radio Frequency Amplifying Transformers can be put to.

32 Pages, 15 Illustrations  
Bound in Beautiful Two-Color Cover. Size, 5½ x 7½ in. Prepaid ..... **25c**

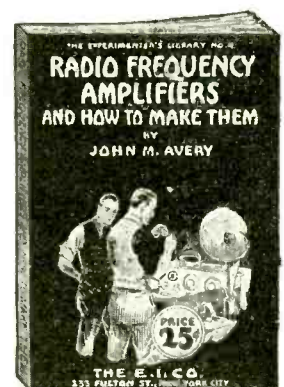

A complete list of dealers carrying these books will be found on page 352

If your dealer cannot supply you—order direct from us—giving dealer's name and address.

**THE E. I. COMPANY (THE CONSRAD CO.) 233 Fulton St., N. Y. City**  
Selling Agents

Large Carbon and Copper Contactors that cannot BURN or STICK.

Sturdy Vibrator gives steady dependable service.

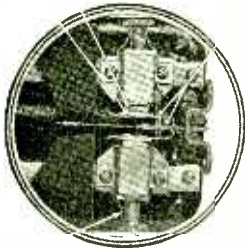

Adjustment Held Permanent.

Easily adjusted when required.

**F-F BATTERY CHARGER**

## Contactors Can't BURN or STICK

They also permit a desirably high charging current that makes for quick and easy storage battery charging.

The F-F Charger is fool-proof and shock-proof. Its simplicity, the satisfactory service it gives year after year, is the result of ten years experience making them.

**\$15.00**

F. O. B. Cleveland

Type 6 charges 6 Volt Storage Battery from any 110 Volt 60 Cycle lamp socket at average rate of 6 amperes.



Buy from your dealer. There's a type for every need. If he cannot supply you, write for literature or enclose remittance covering express or postal charges on 9 lbs.

Write for Complete Details in Bulletin No. 32

**The France Mfg. Co.**  
10432 Berea Road  
Cleveland, Ohio

Pioneer Manufacturers of Patented Battery Chargers

## ELECTRIC SOLDERING IRON

EVERY RADIO FAN has been looking for this iron for both radio and home use. Operates on A. C. or D. C. current.

GUARANTEED one year. Sent anywhere in U. S. or Canada Parcel Post prepaid on receipt of money order for \$2.28.

FANS Send 2c stamp for our list of RADIO BARGAINS

**RADIO BARGAINS**  
17 N. LA SALLE ST. - CHICAGO

## ENGRAVING MACHINES

For RADIO PANELS

And Other Radio Engraving

ENGRAVERS & PRINTERS MACHINERY CO.  
Sag Harbor, N. Y.

described for damped and telephone waves in the previous article, for the characteristic of radio telephone waves is that the amplitude is continuously varying, and it will be observed that the resultant wave has its amplitude continuously variable also.

This system of superimposing another radio frequency wave on the incoming signalling wave, the difference between the two wave frequencies being an audible frequency, is called the *heterodyne system*. In practice there are two ways in which this may be done: First, self-heterodyne or autodyne system, and second, the external heterodyne. In the self-heterodyne system the tube which rectifies is also employed to generate the oscillations which are to be superimposed on the received oscillations. In Fig. 7 is illustrated one of the simplest types of regenerative receivers, employing a tickler coupling coil T. The antenna is tuned to the incoming signals, which have a frequency say of 500,000 cycles per second. The secondary circuit is likewise tuned to it so that we have a current also flowing in it. Suppose now that the tickler coupling coil is moved closer to the secondary coil L until the circuit begins to oscillate. We will now have two currents flowing through the secondary circuit, first the incoming signals, and second, the oscillations developed by the detector tube. The frequency of the oscillations developed by the detector tube will be that of the secondary circuit LC. Hence by varying the condenser C we can vary the frequency of the oscillations generated in it so that it is either 499,000 or 501,000 cycles, or 1000 cycles more or less than those of the incoming signals. Hence beats will be produced at the frequency of 1000 cycles per second and the signals heard. Now when the secondary condenser C is varied so that the frequency of the oscillations generated is 499,000 cycles per second, it means that we have detuned the secondary circuit from the incoming wave frequency. However, this detuning is only 1000 cycles in 500,000 cycles, the frequency of the incoming waves, which is seen to be only 0.2 per cent which is negligible and has very little effect on the strength of the incoming signal. By altering the condenser C the frequency of the generated oscillations may be varied, and in this way the beat frequency also varied, thus permitting the operator to secure a signal note of whatever pitch he desires. In the self-heterodyne the reader will see that a very heavy burden is placed on the single detector tube. The tube must detect or rectify the signal, it must also act as the generator of the superimposed oscillations, and before it can oscillate it must amplify, hence it also acts as an amplifier. This is asking a little too much from a single tube, and it is difficult for one tube to perform all these functions at maximum efficiency. Thus it is possible that the conditions for maximum efficiency as a detector are different from the conditions for maximum efficiency as an oscillator. The tube may do one function well and not the other, for the operator has not the same leeway in adjusting his circuit. If he changes it so that he gets very good oscillation efficiency he may get, as a result, very poor detecting efficiency. In other words such a circuit is not very flexible as it does not permit a wide latitude in adjustments.

SEPARATE HETERODYNE IS MORE EFFICIENT

In order to avoid throwing such a load on one tube the external heterodyne system is used. In this case, Fig. 8, the detector tube simply rectifies, while an ex-

ternal generator of the other radio frequency oscillations is used. It will readily be seen by the reader that this system has many advantages over the self heterodyne. In the first place the detector tube can be adjusted so that it detects at maximum efficiency without any fear as to disturbing any other adjustment, for that is all the detector tube has to accomplish. In the second place the oscillating circuit may also be adjusted to its best efficiency without any fear as to disturbing the detection efficiency. In the third place there is no danger of the detector circuit stopping oscillations, hence stopping reception, as is the case in the self heterodyne system, for sometimes adjusting the detector tube results in causing the oscillations to cease. Finally since an external heterodyne is employed the receiving circuit need never be detuned to generate different frequency waves, for the external heterodyne generates these waves in its own circuit. Thus from every point of view the external heterodyne is the best and it is so used in the best of stations. The pitch of the received signals may be varied by varying the frequency of the external heterodyne circuit.

The heterodyne system of reception is far superior to all the other methods of reception and detection. Its selectivity is excellent, that is it is able to discriminate between waves and omit those that are not desired. Its sensitivity is unequalled by any other system. With respect to its sensitivity it has a most unusual characteristic: it is tremendously sensitive to currents of weak strength while it is not so sensitive to currents of strong strength. This makes possible loop reception with the heterodyne and it is also very useful in the reduction of static and other strong interferences, for while the signal may be very weak it is amplified a great many times by the heterodyne action, but if a strong static or other interfering signal is imposed on it the amplification is very weak. In this way the signal response is greatly increased over the static or interference response.

In the use of a heterodyne circuit such as shown in Fig. 7 or 8, amateurs frequently experience certain difficulties. One of these is that the external oscillator does not oscillate. The most frequent cause of this will be found to be the connection of the tickler coil T. If this coil is not properly connected oscillations will not occur. The novice should therefore try his circuit with terminals of coil T connected one way, and if this connection does not give results he should reverse the connections. A simple way to tell if the tube is oscillating or not is to touch the grid terminal connection with a moist finger and then remove finger. If the tube is oscillating a loud click will be heard in the phones on touching grid and removing it. If it is not oscillating there will be either no click heard or one click will be very faint. In the case of the oscillating state a loud click is heard both when grid is touched and when finger is removed. If varying the tickler connection does not show oscillations your tickler coil is not properly coupled to the secondary coil. Vary the coupling slowly, starting with loose and going towards tight coupling, and make tests as above for oscillations. By doing this for both types of tickler coil connection the condition for oscillations will be obtained.

A second cause for confusion in this type of detection for the inexperienced novice is the large variety of sounds and noises heard in the telephones. These noises may be clicks spaced at wide in-

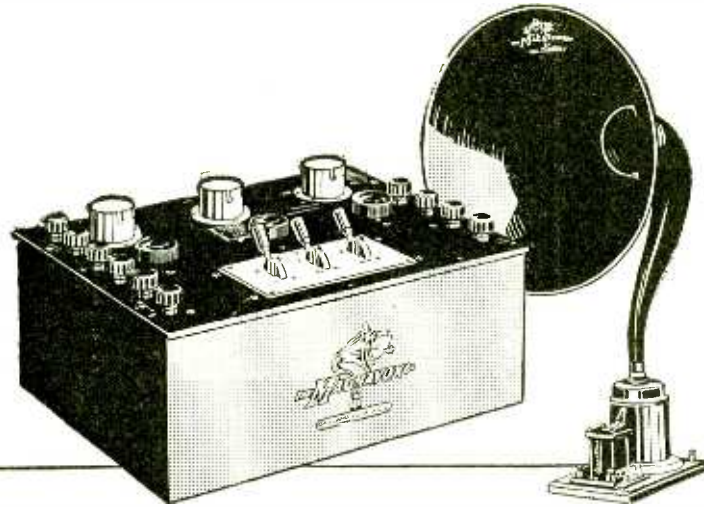

# MAGNAVOX and FORMICA

**T**HE radio engineers of the Magnavox Company have given their approval to Formica in the most sincere and convincing way — by using it exclusively in their apparatus for a long time.

Think over the list of great independent radio manufacturers whose standing and prestige in radio counts for something, and you will find almost every one among the regular users of Formica.

The only reason is that Formica is better looking, more uniform, more efficient than any other radio insulation of the kind. They have tested and tried them all and they *know*.

*Your dealer will supply you promptly with a Formica panel in any of the standard sizes, or in any special sizes.*

*Dealers:* Sell panels in the size your trade demands — not a few sizes that some one else wants you to carry. You will find Formica sales and advertising support and its wonderful nation-wide reputation a big help in building up your sales of panels and tubes.

THE FORMICA INSULATION COMPANY  
4618 Spring Grove Ave., Cincinnati, Ohio

#### Sales Offices

50 Church St., New York, N. Y.  
422 First Ave., Pittsburgh, Pa.  
1042 Granite Bldg., Rochester, N. Y.  
415 Ohio Bldg., Toledo, Ohio

1210 Arch St., Philadelphia, Pa.  
1819 Lyndale Ave., S. Minneapolis, Minn.  
Sheldon Bldg., San Francisco, California  
Whitney Central Bldg., New Orleans

414 Finance Bldg., Cleveland, Ohio  
9 S. Clinton St., Chicago, Ill.  
313 Title Bldg., Baltimore, Md.  
47 King St., Toronto, Ontario

# FORMICA

Made from Anhydrous Redmanol Resins  
SHEETS TUBES RODS

## USE A C H SHARP TUNER DIALS

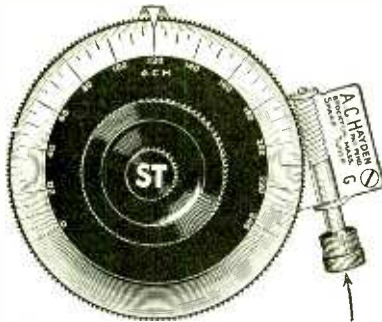

Why the A.C.H. is different

3 in. DIAL

156-TO-1

4 in. DIAL

215-TO-1

Rough tuning with dial or one thousandth of an inch in either direction.

### Money Back Guarantee

Price A.C.H. 3" Dial complete ..... \$2.50  
 Price A.C.H. 4" Dial complete ..... 5.00  
 Regular fitting 5/16" hole, 3/4" and 3/16". Bushings, 5c. each extra. 10c for all.

### LONG DISTANCE A C H DETECTOR SET UNWIRED

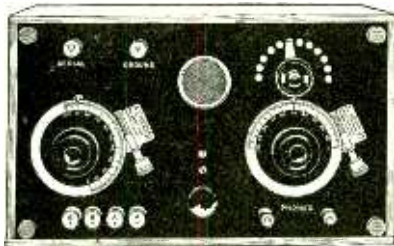

PRICE \$20.00 Including 2-3" A.C.H. Dials  
 WRITE FOR 3 WAYS TO PURCHASE

**A. C. HAYDEN RADIO & RESEARCH CO.**  
 Brockton, Mass., U. S. A.  
 Mail Orders sent prepaid in U. S. A.

tervals, or they may be squealing noises or hissing noises. These noises are due to improper values of grid condenser and leak, and to too close tickler coupling. The noises are in reality due to the fact that the radio frequency oscillations which are generated in the tube start and stop intermittently; this starting and stopping takes place at an audio frequency rate which is therefore heard in the phones. The starting and stopping of the radio frequency oscillations are made possible by the variations in the potentials which build up on the grid and which leak off through the grid leak. The larger the leak resistance is made the longer it takes for this negative voltage to leak off the grid, hence the less frequently the oscillations start, and so the noises are low pitched noises, and vice versa. Variations of the grid potential may likewise be produced by too tight tickler coupling. The grid condenser and leak must have proper values for any given tube in order that these noises be avoided.

The novice now has a fair idea of the principle methods employed in the detection of all types of radio frequency waves and is therefore in a position to study the next logical subject, namely amplification. This will therefore be the next topic to be treated.

## Multi-Layer Coils

(Continued from page 269)

wind a set of lattice coils, especially if the former can be mounted on some sort of spindle (or chucked in a lathe, of course), so as to be easily revolved, and they will be found very satisfactory for medium- and long-wave tuning. Data for a set to cover approximately 1,000 to 20,000 meters are given above.

| Coil | Turns. | Turns per Layer. | Wire.     |
|------|--------|------------------|-----------|
| 1    | 200    | 10               | 24 D.C.C. |
| 2    | 300    | 15               | 24 "      |
| 3    | 400    | 20               | 26 "      |
| 4    | 500    | 20               | 26 "      |
| 5    | 750    | 20               | 30 "      |
| 6    | 1,000  | 30               | 30 "      |
| 7    | 1,250  | 30               | 30 "      |
| 8    | 1,500  | 40               | 30 "      |

Diameter of former, 5 cm.; number of pins per row, 12; distance between rows of pins (i.e., thickness of coil): coil 1, 1 cm.; coils 2-5, 1.5 cm.; coils 6 and 7, 2 cm.; coil 8, 2.5 cm.

The data given, it should be explained, have been worked out to give a good compromise between compactness on the one hand, and efficiency on the other; if greater compactness is desired, it can be obtained at a slight sacrifice of efficiency by winding coils 1-4 with No. 28 D.C.C. wire, and coils 5-8 with No. 32 D.C.C. wire.

### MODIFICATIONS OF THE LATTICE COIL

I have found that the lattice coil is exceedingly useful as a starting-point for the origination of new systems of coil-winding, a little ingenuity sufficing to produce quite a variety of such modifications.

The two examples which follow are the most useful of the various types which I have obtained in this way. The first coil is of the flat disc or pancake type, which is convenient for some coupling purposes, and is intended to replace the basket coil, over which it has considerable advantages in mechanical strength, compactness, and quickness of winding. It is simply a lattice coil of only two turns per layer, those two being spaced apart, as shown in section in Fig. 11.

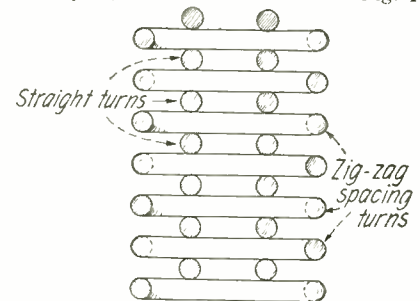

Fig. 11. Section of a Disc Type of Lattice Coil. The Same Method of Spacing the Layers is Adhered To.

It is wound upon a former which differs from the one already described in that its two rows of pins are only 7 or 8 mm. apart, and the method of winding is as follows: First the zigzag turn with which every lattice coil begins, then a turn straight round close against the pins on one side of the former, across on a slant to the other side, and then one turn round against the other pins. Fig. 12 shows these first three turns, and should make the matter plain. After this, zigzag spacing turns alternate with layers composed of two straight turns until the coil is finished. On the completion of the coil tie the last turn tightly to the zigzag one beneath it with thread at two points, wax the coil and remove it from the former

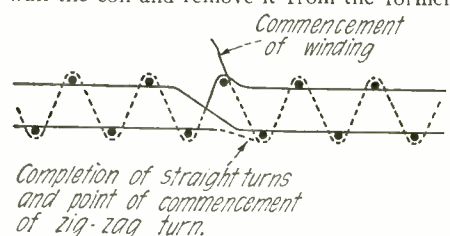
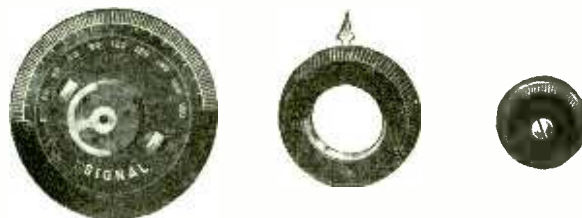

Fig. 12. Plan for Winding the Disc Type of Lattice Coil. The Spacing Wire Is Shown by Dotted Lines.

## "SIGNAL" Vernier Dial Attachment for Plate Condenser



Attach to any plate condenser having 1/4 in. or 3/16 in. dial extension shaft.

The dial assembly is itself a Vernier, offering extremely fine adjustment. Body is Bakelite, with brass parts molded-in. Worth its weight in gold in the pleasure value it adds to any receiving set.

No. R-130. Vernier for Plate Condenser, each, by mail postpaid, \$2.50.

No. R-33. Vernier Rheostat, size 2 1/8 in. dia. by 2 in. high, each, by mail postpaid, \$1.50.

Jobbers and Dealers. Send for our catalog of Radio Sets and Parts. Liberal quantity discounts.

## SIGNAL Electric Mfg. Co.

FACTORY AND GENERAL OFFICES  
 1912 Broadway, Menominee, Mich.

Atlanta, Boston, Chicago, Cleveland, Minneapolis, Montreal, New York, Pittsburgh, St. Louis, San Francisco, Toronto.  
 You'll find our local address in your Telephone Directory

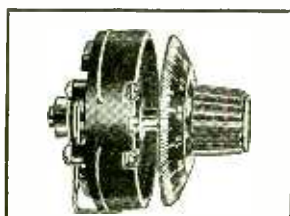

### SIGNAL VERNIER RHEOSTAT

Both vernier slider and main slider controlled by same knob. To adjust tubes, turn up main slider till tube hisses, then reverse the rotation and make fine adjustment with vernier slider alone. Arranged for base or panel mounting.

**DENVER**  
 COLORADO  
**REYNOLDS RADIO CO.**  
 9ZAF KLZ  
 1534 Glenarm St.  
 LARGE RADIO DISTRIBUTORS

**VULCANIZED FIBRE**  
 Be sure and specify "WILMINGTON FIBRE"  
 Sheets, Rods, Tubes, Washers, Etc., Specialties  
 Wilmington Fibre Specialty Co. Wilmington, Del.  
 Branch Offices "Everywhere"

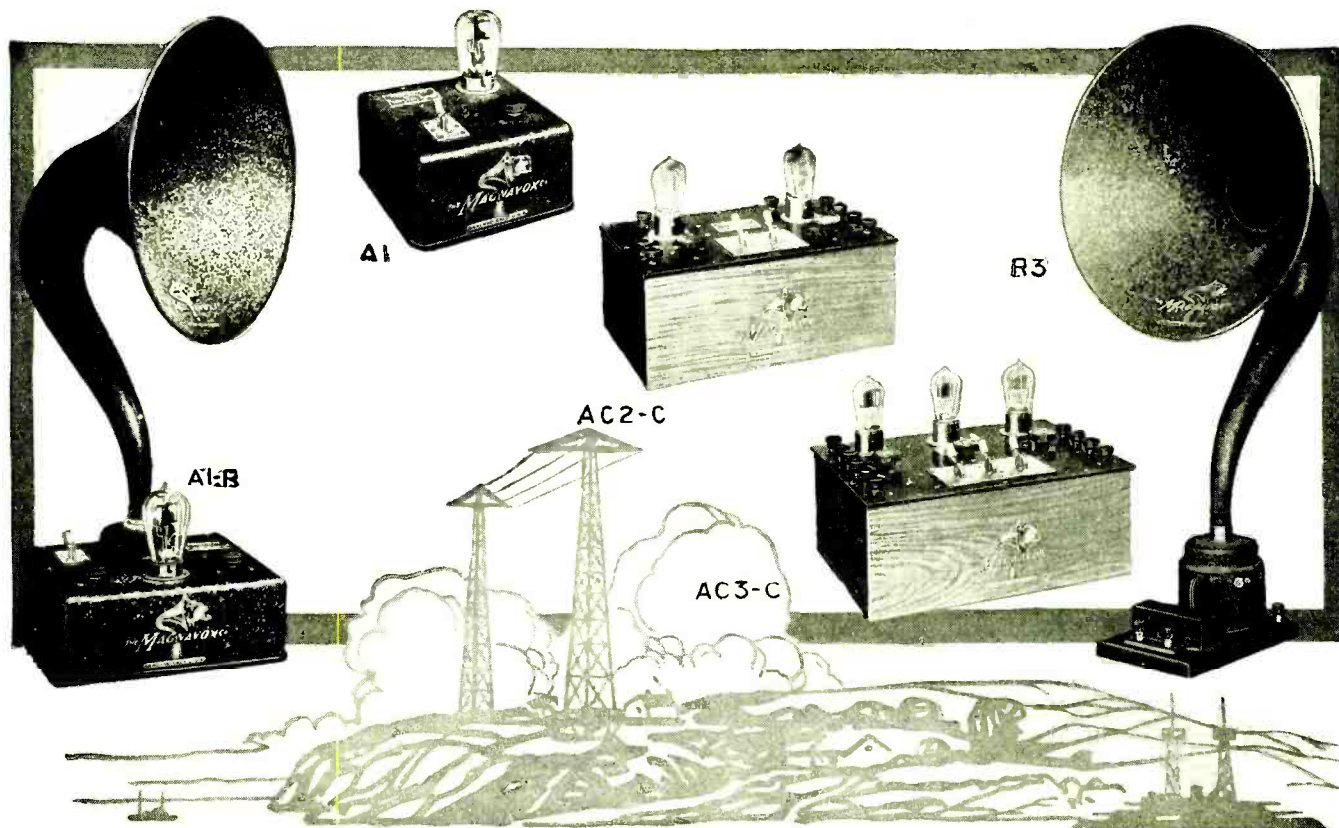

**New Magnavox Combination Set**

A2-R Insures convenient and perfect Radio reproduction. Consists of Magnavox Reproducer with 14-inch horn and 2-stage Magnavox Power Amplifier, as illustrated \$85.00

## Radio takes another step forward with these wonderful new Magnavox devices

THE new Magnavox models here shown extend and supplement the already famous Magnavox line of Reproducers and Power Amplifiers. There is a Magnavox for every receiving set.

### Magnavox Reproducers

- R2 with 18-inch curvex horn in new acoustic finish . . . \$60.00
- R3 with 14-inch curvex horn in new acoustic finish . . . 35.00
- M1 new Magnavox Reproducer requires no battery for the field, thus meeting requirements of dry battery receiving sets. With 14-inch curvex horn in new acoustic finish . . . 35.00

### Magnavox Combination Sets

- A1-R consisting of Magnavox R3 Reproducer with 14-in. horn and 1-stage Magnavox Power Amplifier . . . 59.00
- A2-R consisting of Magnavox R3 Reproducer with 14-in. horn and 2-stage Magnavox Power Amplifier . . . 85.00
- A1-M same as A1-R but with the new Magnavox Reproducer M1 . . . 59.00

- A2-M same as A2-R but with the new Magnavox Reproducer M1 . . . \$85.00

### Magnavox Power Amplifiers

- A1 meets the demand for a 1-stage Power Amplifier. Special finish metal case. . . 27.50
- AC-2-C Magnavox 2-stage Power Amplifier with Bakelite panel in highly finished hardwood case . . . 55.00
- AC-3-C Magnavox 3-stage Power Amplifier . . . 75.00

Ask your dealer for a demonstration. Interesting booklet will be sent on request.

**The Magnavox Company**  
 OAKLAND, CALIFORNIA  
 370 Seventh Avenue, New York  
 World pioneers in the development and manufacture of sound amplifying apparatus

# MAGNAVOX PRODUCTS

## Magnavox Reproducers and Amplifiers

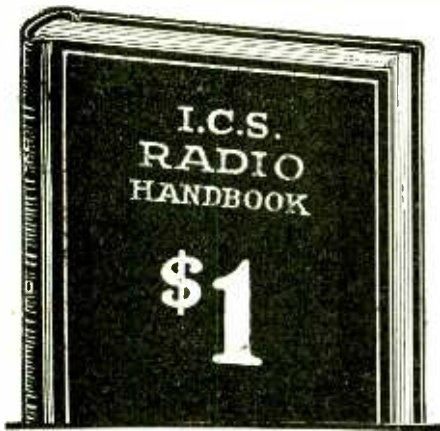

## Every Radio Fan Should Have This Book

Price Only



562 pages  
Pocket Size

Compiled by  
HARRY F. DART  
B.S.E.E.

Formerly with the Western Electric Co., and U. S. Army Instructor of Radio.

Technically edited by  
F. H. DOANE

LIKE a little radio encyclopaedia, this I. C. S. Radio Handbook is packed with concise, sound information useful to everybody from beginner to veteran hard-boiled owl. It starts with simple explanations of radio phenomena and leads you along gently until you can understand the most technical diagram.

You may dip into it at random, or hunt up special information you want, or read it right through. Different types of receiving and sending hook-ups are explained; proposed insurance regulations; lists of broadcasting stations; radio compass stations; interesting experiments; definitions; codes and symbols; technical data and thousands of suggestions for getting more pleasure out of radio.

### A pocket course in radio!

Every page tells you something useful, and there are 562 pages; hundreds of illustrations and diagrams. It is the biggest dollar's worth in radio, and will save you from wasting money on things that don't work.

Send \$1 to-day and get this 562-page I. C. S. Radio Handbook before you spend another cent on parts. Money back if not satisfied.

TEAR OUT HERE

INTERNATIONAL CORRESPONDENCE SCHOOLS  
Box 8281, Scranton, Penna.

I enclose One Dollar. Please send me—post-paid—the 562-page I. C. S. Radio Handbook. It is understood that if I am not entirely satisfied I may return this book within five days and you will refund my money.

Name.....

Address.....

### Practical Radio Operating

Code room equipped with Kleinschmidt automatic transmitter, thorough preparation for passenger and freight ship radio operator's position. Write today for our booklet

"When in New York Pay Us a Visit"  
Arc-Spark-Vacuum Tubes.

### Y. M. C. A. RADIO SCHOOL

"Best Radio School in the East"

158 East 86th Street, New York City



### REFLEX CIRCUIT

regenerative, crystal and 2-Step Amplifier circuits with Radio Catalog for only 10c.

ERNEST ELECTRIC CO.  
4847 Easton Ave., St. Louis, Mo.

as before. It should perhaps be mentioned at this point that with all multi-layer coils it is generally worth while to tie the first turn to the one above it, and the last turn to the one beneath it, to eliminate any tendency to unwind. (Note: In the case of lattice coils "first turn" does not mean the zigzag turn which is put on at the commencement of winding, since this is always intended to be pulled out after the coil has been waxed, to enable one to remove it from the former.)

The second type is one whose use for all short-wave purposes I strongly advocate, since it is distinctly the best multi-layer coil which I have yet tested. The system of winding is such that the superimposed turns are separated by quite as great a space as in the popular duo-lateral coil, and they are separated electrically by smaller differences of potential. This system was originated very simply from the preceding one by applying the duo-lateral principle and "staggering" the turns which come vertically above each other, as shown in section in Fig. 13. Instructions

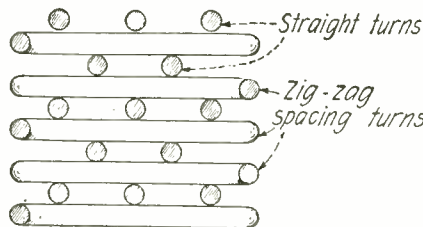

Fig. 13. Showing the Application of the Duo-Lateral Principle to a Lattice Winding.

for winding this coil are scarcely necessary, the only points requiring mention being, first, that the straight turns are placed in position by eye, which will prove quite easy when once the first three-turn layer has been put on. Second, that all the straight-turn layers must commence on the same side of the former, and all must finish on the opposite side. Thus, it will not do to begin a three-turn layer on the right and finish it on the left, and then begin the succeeding two-turn layer on the left and finish it on the right. The reason for this will become plain when the first coil is wound.

Coils of this type, by the way, are not upon the market, nor, so far as I am aware, are they likely to be.

### HONEYCOMB AND DUO-LATERAL COILS

The honeycomb coil in its improved form, the duo-lateral, is generally regarded as one of the best of multi-layer coils, and it is therefore regrettable that it is such a tedious and difficult one to wind. By hand it must be regarded as an impracticable task to wind anything but the smaller sizes, the large ones requiring either a coil-winding machine or an inexhaustible stock of patience. Small coils can be fairly easily wound by hand upon a former resembling that used for lattice coils, the only difference being that many more pins are required for the duo-lateral. Such coils are usually somewhat superior to those produced by a machine, since one can wind much thicker gauges of wire by hand than a machine will deal with satisfactorily, and can, therefore, produce a coil of lower resistance and lower internal capacity (the latter resulting from the greater spacing between turns caused by the thicker wire).

It is almost impossible to convey a clear idea of the nature of the honeycomb and duo-lateral systems by verbal description, and I must invoke the aid of some diagrams. The essential characteristic of both systems is that the wire in passing round the former travels slantingly from side to side of the coil. On the completion of each revolution a fresh turn is begun at a point a few degrees ahead of, or behind, the spot at which the previous one started. An attempt is made to show this in Fig. 14 (a) which is a



### STROMBERG-CARLSON RADIO HEADSETS

Are balanced as to volume—both ears get the message.

This means that the receivers are mated—a feature which permits the users enjoying the sensation of hearing equally well from both receivers. Stromberg-Carlson Head Sets have three more distinctive features, which you will like—

1. The receivers are layer wound and layer insulated—to stand up under high plate voltages.
  2. The ear caps cover the ears—excluding outside noises.
  3. The adjustment rod telescopes, therefore it does not catch the ladies' hair.
- Order Stromberg-Carlson apparatus through your electrical dealer or write us for free bulletin No. 1029-R

STROMBERG-CARLSON Telephone Mfg. Co.  
Rochester, N. Y.



### CUT PRICES

To Consumers

|  | Regular List | Our List |
|--|--------------|----------|
| 1½-volt Tube .....                       | \$ 6.00      | \$ 4.50  |
| 1½-volt Amp. Tube....                    | 6.75         | 4.75     |
| Baldwin type C Phones                    | 16.00        | 13.00    |
| Magnavoxes .....                         | 45.00        | 37.00    |
| Murdock Phones, 2000                     |              |          |
| Ohm .....                                | 5.00         | 4.20     |
| Murdock Phones, 3000                     |              |          |
| Ohm .....                                | 6.00         | 4.90     |
| Acme Transformers ...                    | 5.00         | 4.20     |
| Plugs .....                              | 1.50         | .59      |
| Rheostats .....                          | 1.00         | .50      |
| Moulded Sockets ....                     | .75          | .45      |
| B Batteries, 22½-volt..                  | 1.25         | .80      |
| Crystal Detectors ....                   | 1.00         | .60      |
| Contact Points, per doz.                 | .35 per doz. | .15      |
| Switches, tapered knob                   | .35          | .20      |
| Honeycomb Coils, all sizes 25% discount. |              |          |
| Paragon Ra 10.....                       | 110.00       | 68.00    |
| Variometers .....                        | 3.50         | 2.50     |
| Variocouplers .....                      | 1.50         | 1.10     |
| Dreyfuss Phones .....                    | 8.00         | 7.00     |
| 3-inch Dials .....                       | .75          | .30      |
| Rheostat Dials .....                     | .50          | .23      |
| No. 14 Hard-drawn                        |              |          |
| Aerial Wire, C ft....                    | .60 C ft.    | .38      |

We give a discount of 10% on all standard merchandise not listed.

MAIL ORDERS ONLY No STORE TRADE

Mail check or money order.  
No stamps or currency.

### RADIO CUT PRICE CO.

320 Broadway, New York City



Installation of Willard Rechargeable Radio "B" Batteries at WJAX—The Union Trust Company, Cleveland, O.

# 34 Broadcasting Stations Adopt the Noise-Proof Battery

**These Broadcasting Stations use Willard Rechargeable Radio Storage Batteries.**

- |                                  |   |
|----------------------------------|---|
| WJAX and WHK<br>Cleveland, O.    | WGF<br>Des Moines, Ia.                      |
| WWJ and WCX<br>Detroit, Mich.    | WBAH<br>Minneapolis, Minn.                  |
| WDAF and WHD<br>Kansas City, Mo. | WHAZ<br>Troy, N. Y.                         |
| KSD<br>St. Louis, Mo.            | WJAR, WTAG and<br>WEAN<br>Providence, R. I. |
| WSB and WGM<br>Atlanta, Ga.      | WDAE<br>Tampa, Fla.                         |
| WBAP<br>Ft. Worth, Texas         | WDAP<br>Chicago, Ill.                       |
| WDAO and WFAA.<br>Dallas, Texas  | KLZ<br>Denver, Colo.                        |
| WOAW<br>Omaha, Nebr.             | WWI<br>Dearborn, Mich.                      |
| WEV and WCAK<br>Houston, Texas   | WHAM and WABA<br>Rochester, N. Y.           |
| WCAG<br>New Orleans, La.         | WDAL<br>Jacksonville, Fla.                  |
| WOC<br>Davenport, Ia.            | WOAM<br>Miami, Fla.                         |
| WHA<br>Madison, Wisc.            | WMC<br>Memphis, Tenn.                       |
|                                  | WOAI<br>San Antonio, Texas                  |

Thirty-four of the leading broadcasting stations—each in charge of an expert—have selected Willard Rechargeable Radio "B" Batteries because of their great distinctness in reproduction and clear, powerful amplification—also because they maintain their voltage for long periods without recharging.

Willard Rechargeable Radio "B" Batteries will give the same results with your receiving set, bringing in signals clear and strong and getting rid of the noises produced by electrical leakage, internal action, or subnormal voltage of your "B" batteries.

With only occasional recharging, Willard "B" Batteries will always be at top-notch efficiency, and they last for years.

Ask your dealer for the free booklet "Better Results from Radio" or write the Willard Storage Battery Company, Cleveland, Ohio.

# Willard Rechargeable Batteries for Radio



**You Can't Play a Tune On a Cowbell, Nor Can You Expect To Get Music from "One Frequency" Transformers.**

**The Pacent Audioformer**



No. 25 Audioformer equipped with binding posts. PRICE \$4.50



No. 25A Audioformer binding posts replaced with leads for soldering connections. PRICE \$4.00

Receives without distortion the wide range of sound frequencies encountered in broadcasted music and speeches. The Audioformer is also extremely compact (approximately 2" high) and easy to mount, being provided with an angle piece requiring only two screws. This transformer has the ideal attributes for the satisfaction of the amateur set builder and broadcast listener and is just one member of the line of Pacent Radio Essentials insuring more efficiency, convenience and enjoyment

from radio operation. Send for bulletins N-9.

**PACENT ELECTRIC CO., Inc.**  
22 Park Place, New York

Sales Offices: Chicago, Philadelphia, St. Louis, Minneapolis, Washington, D. C., San Francisco and Jacksonville

**Pacent RADIO ESSENTIALS**

**Long Distance Crystal Set**

We receive programs from Atlanta, Minneapolis, Davenport, Fort Worth, Dallas, Kansas City, St. Louis, Denver on Crystal without batteries. Usual crystal set requires only easy, inexpensive changes. Send stamp for further information or \$1 for copyright drawings and instructions. Everything clearly explained. Satisfaction GUARANTEED. Leon Lambert, 595 South Volusia, Wichita, Kan.

**Easy Now to Make & Repair Electrical Appliances GENUINE NICHROME WIRE, \$1.00 Prepaid**

This resistance wire is the business end of standard electrical appliance. 27 feet guaranteed up to 660 watts, 110-120 volts, 6 amps. With this you can make or repair your own electrical ranges, furnaces, sadirons, toasters, curling irons, waffle griddles, etc. Complete package with copper and mica washers, nuts screws and full instructions sent prepaid for One Dollar. Or order C.O.D. and pay few cents extra postage.

ALLIED FACTORIES CORPORATION  
1007 Coon Cola Bldg. Kansas City, Mo.

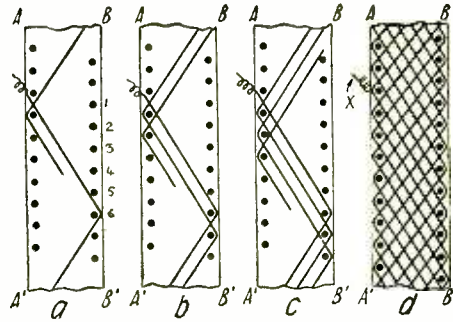

Fig. 14. Showing the Method of Winding a Honeycomb Coil. The Wire Progresses One Peg At Each Turn.

plan of the surface of the former, with the pins represented by dots, upon which one turn of wire has been wound. It must be emphasized that the figure is a plan of the whole surface of the former, not half of it. Thus, to accurately represent the original, the paper would have to be bent round so that the lines AB, A<sub>1</sub>B<sub>1</sub>, met to make the diagram circular. Figs. 14 (b) and 14 (c) show the effect of adding turns one at a time, while Fig. 14 (d) shows the first layer completed. The second layer would begin at the point X, and would follow exactly the turns of the layer beneath (from which it is separated by the turns running cross-wise), thus preserving the cellular structure seen in Fig. 14 (d) which gives the coil its name. It will be noted that the wire on passing round a pin on one side of the former slants across to the other side and passes round the sixth pin, counting six in this way every time it crosses over. This is indicated by the numbers on Fig. 14. In the case of the honeycomb any convenient number may be used, according to the closeness of winding desired (the larger the number the closer the winding). It is worth noting that the number of turns per layer is fixed by the number of pins "counted" in crossing over; in the example figured it can be ascertained by actual enumeration that each layer consists of twelve turns, which is twice the number of pins "counted." This rule holds good for all honeycomb and duo-lateral coils, irrespective of the number of pins on the former, and is very useful when one is designing, say, a series of coils to have specified numbers of turns. For example, suppose one has to wind a coil of 70 turns, and wants to know how many pins to count, and how many layers will be needed: try 5 layers:

$$70 \div 5 = 14$$

$$14 \div 2 = 7$$

Therefore, count 7 pins in crossing over, thus obtaining 14 turns per layer, and wind on 5 layers. If greater openness of winding were required, to give a coil of greater bulk and extra low self-capacity, one could put the same number of turns into 7 layers, which would require 10 turns per layer, and therefore one would have to "count" 5 pins at each crossover.

The number of pins on the former may be any convenient figure, from 10 to 20 in each row, in the case of the honeycomb, but has to be one of certain definite numbers in the case of the duo-lateral. This latter coil is of a very similar cellular structure to the honeycomb, the difference being that in the duo-lateral the turns in one layer do not lie exactly above those in the one beneath, but come over the spaces between them. Fig. 15 shows this difference by means of sections through (a) a honeycomb, and (b) a duo-lateral winding. It is evident that the latter has nearly three times the space separating the turns in a vertical direction, and its capacity is, therefore, lower. The reduction is sufficiently considerable to make the duo-lateral almost universally used.

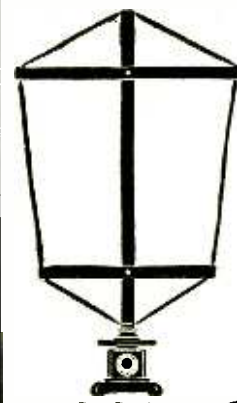

**STATIC and Interference is Reduced to a Minimum**  
**Better Reception with the NASSAU**



Pat. Pending  
Price \$35.00  
Jobbers and Dealers Write for Proposition

Eliminates Aerial and Ground.

The Secret is in the Patented Winding  
**1500 MILES ON LOUD SPEAKER**

With 2 stages radio and 2 stages audio frequency amplification.

Write for Circular "R"  
Manufactured by

**NASSAU RADIO CO., Inc.**  
60 Court St., Brooklyn, N. Y.

**KLAUS RADIO SERVICE**  
Makes Money for Dealers



**Get Free Bulletin**

Klaus Radio Dealers receive expert service in radio problems and in radio merchandising. Our dealers make more money. We want a dealer in every city and town. Some territory is still open. Write for our trade discount lists and the "Klaus Radio Bulletin."

**KLAUS RADIO & ELECTRIC CO.**  
Authorized Distributors  
Dept. 200 EUREKA, ILL.

**KLOSNER RADIO PRODUCTS**

Send for free literature.

**KLOSNER IMPROVED APPARATUS CO.**  
2024 BOSTON ROAD NEW YORK CITY

NEW CARTER



JACK SWITCH

For closing battery circuits, etc. See your dealer. Mounts like a Jack. Price \$1.00—Write for free Jack Switch hook-ups.  
CARTER RADIO CO. 207 S. State St. Chicago





## Just pick out the size you want

**C**ELORON Radio Panels, ready-cut in standard sizes, save you the trouble and delay of having your panel cut to order. Just go to a near-by radio dealer who sells Celoron panels and pick out the size you want. Then you are sure of getting a panel that is neatly trimmed and finished, and something more—you get the necessary insulation for successful receiving.

Condensite Celoron has high dielectric strength and great insulation resistance. Its moisture-repelling properties prevent warping.

### *Easy to work*

You will like the "workability" of Celoron panels. They are easy to drill, tap, saw, and mill, and will engrave evenly without feathering. Each panel is wrapped in glassine paper to protect the surface. On every one are complete instructions for working and finishing. You can get Celoron panels in glossy black finish.

One of these standard sizes will fit the set you intend to build:

|                          |                           |
|--------------------------|---------------------------|
| 1—6 x 7 x $\frac{1}{8}$  | 4—7 x 18 x $\frac{3}{8}$  |
| 2—7 x 9 x $\frac{1}{8}$  | 5—9 x 14 x $\frac{3}{8}$  |
| 3—7 x 12 x $\frac{1}{8}$ | 6—7 x 21 x $\frac{3}{8}$  |
|                          | 7—12 x 14 x $\frac{3}{8}$ |

If your dealer cannot supply you, ask him to order for you, or write direct to us. Indicate by number the size you want. Celoron is also furnished in full-sized sheets, and we can cut panels in any sizes desired.

### *Write for this free booklet*

You will find much that will interest you in our booklet, "Tuning in on a New World." It contains lists of the leading broadcasting stations in the United States and Canada, an explanation of symbols used in radio diagrams, and several efficient radio hook-ups. We will send this booklet to you free on request. A line on a card is sufficient. Write at once.

*To radio dealers: Send for special dealer price list showing standard assortments*

## Diamond State Fibre Company

BRIDGEPORT (near Philadelphia) PENNSYLVANIA

BRANCH FACTORIES AND WAREHOUSES  
BOSTON CHICAGO SAN FRANCISCO

Offices in Principal Cities

In Canada Diamond State Fibre Company of Canada, Limited, 245 Carlaw Ave., Toronto

CONDENSITE  
**CELORON**  
STANDARD RADIO PANEL

**FORMAN & Co.,**  
**Broadcasting**  
*To The Trade*

The Merits of Our



**RADIO ACCESSORIES**

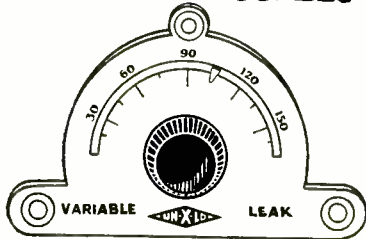

Variable Grid Leak. 0-5 Meg. Specially formed tension contact. Permanent, impregnated Grid Line—with Composition, tapered knob.

List price .....25c



Mica Condensers of all capacities. TESTED and GUARANTEED accurate to rated capacity.

List price .....25c



Rheostat

Paper condensers  
 Mounted crystals  
 Detectors  
 180° Couplers  
 Sockets  
 Binding Posts  
 Switch Levers  
 Contact Points  
 Sliders

Contact—Phosphor Bronze on Periphery of coil winding. Base—of High Heat-resisting, black polished composition. 6-30 Ohms.

List price .....60—70c

Wholesale only. Dealers, in sending orders, kindly name jobber with whom you trade.

WRITE TO-DAY FOR TRADE DISCOUNTS.

**FORMAN & CO.**

Manufacturers

366 Greenwich Street, New York

the simple honeycomb now being rarely met with.

The actual difference in winding which produces the duo-lateral formation is difficult to describe, and, besides taking much space, would be of little interest or assistance. If the experimenter employs the following data and winds a coil, he will obtain a clearer idea of its structure than many pages of description could give him. To construct the duo-lateral winding it is necessary to use a former upon which the pins are separated by an odd number of degrees. Thus, 24 pins per row (48 in all) will fulfill the requirements. Also, certain fixed numbers must be counted at each cross-over in winding. Those most commonly used are 6, 7 and 9.

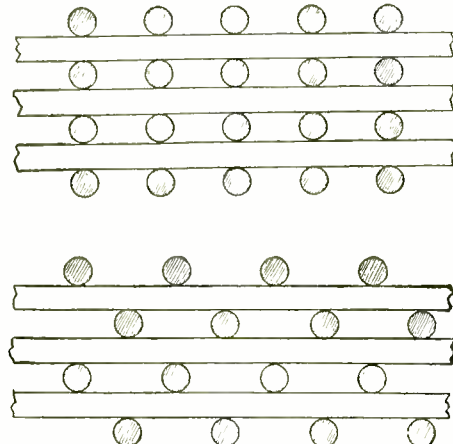

Fig. 15. Above (a), a Cross-Section of the Winding of a Honeycomb Coil. Below (b), the Cross-Section of a Duo-Lateral Winding.

One or two points deserve mention concerning the practical details of winding. It is desirable to tie the first and last turns above and below respectively at two or three points with thread, to prevent any unwinding of the coil during the operation of mounting on a plug when finished. In order to be able to remove the coil from the former easily after it has been soaked in wax and cooled, it is essential to make use of some such device as to wind upon the former a single layer of sewing cotton before starting the coil. Fasten the two ends of the layer of cotton where they will be easily got at, then after waxing the coil and extracting the pins, you can pull out the cotton and the coil will slip off quite freely. Finally, great care should be taken to drain all superfluous wax out of the coil, lest the inter-spaces of the winding remain filled with wax when cool, which would of course, increase the self-capacity considerably.

**Proper Antenna for Tuning**

(Continued from page 261)

to be practically equal to the high one, when a regenerative receiver is used. But should the antenna be located where it is considerably shielded, as where it is surrounded by high buildings, it is possible that the signal strength will be greatly influenced by height. In this latter condition, it will probably be necessary to make up for the poor selectivity of the high antenna by using a somewhat elaborate receiving apparatus. Under the conditions surrounding the average residence district, it usually is possible, with care in the location of the antenna, to maintain good signals, even though the height is considerably less than with the scheme generally employed of attaching the hori-



THE  
**SATURN**

"Automatic"  
 Radio Plug

**\$1.25**

Truly "Automatic"

Also

**SATURN**  
 "Perfect" Jacks

They are all their name implies—"Perfect"  
 From 50c. to 80c. each

**The Saturn Mfg. & Sales Co., Inc.**

Dept. R.N.  
 48 Beekman Street  
 New York, N. Y.

**Radio Dealers Tie Up**

With

**Ludwig Hommel & Co.**

- (1) Their discounts are liberal.
- (2) They wholesale to dealers exclusively and do not compete with their dealers by retailing.
- (3) They carry an enormous stock of sending and receiving material, insuring you quick shipment and a positive source of supply.
- (4) They maintain a Dealer's Service Department to help you with your problems. This service is free and cheerfully given.
- (5) They are distributors for the Radio Corporation of America and all the other leading manufacturers.
- (6) You can rely absolutely on Ludwig Hommel & Company apparatus. It is guaranteed by the manufacturers and by them.
- (7) They do more advertising than any other distributors of Radio Apparatus and refer to their dealers consumers' inquiries resulting from that advertising.
- (8) They have been wholesale distributors for 16 years and play square with everybody at all times.

Ask for Hommel's Encyclopedia of Radio Apparatus 235S and order your requirements now for immediate delivery.

**LUDWIG HOMMEL & CO**  
 530-534 FERNANDO ST. PITTSBURGH, PENNA.

**199 NECESSITIES**

|                    |             |
|--------------------|-------------|
| WIMCO 199 SOCKET   | .....\$ .75 |
| WIMCO 199 C SOCKET | .....1.00   |
| WIMCO 199 ADAPTER  | ......75    |

Send for free literature.  
 Jobbers' inquiries solicited.

**THE WIRELESS MFG. CO.,** Canton, Ohio  
 MANUFACTURERS—DISTRIBUTORS

**A QUALITY BATTERY**

Always Dependable

Marko Storage Battery Company  
 1404 Atlantic Ave.  
 Brooklyn N. Y.



**PERMANITE: The Wonder Crystal**

An absolute innovation in the radio crystal field. Permanite Synthetic Crystal is invariably sensitive on EVERY PART OF ITS SURFACE. Lasts two years. No loss of sensitivity through spark reception. Sold on money-back guarantee.

PERMANITE and SPECIAL CAT WHISKER .....40c.

Sole Distributors

**P. M. DREYFUSS CO., Inc.**  
 150 Chambers Street, New York City

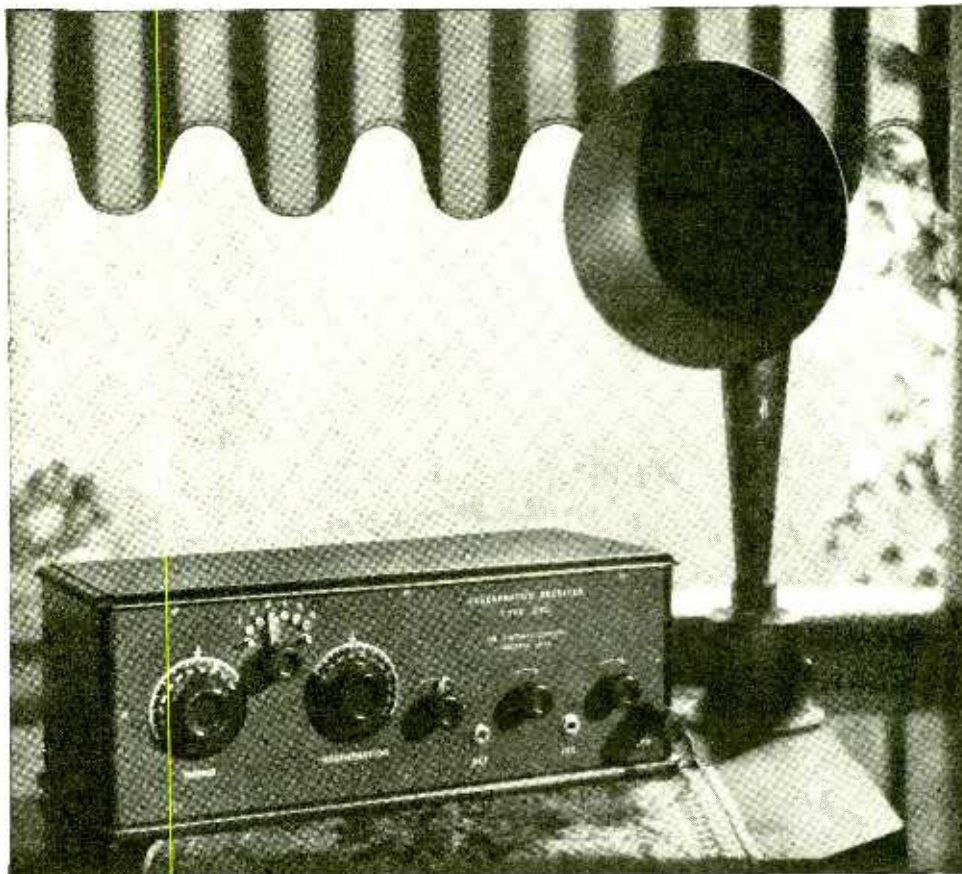

The New Tuska  
Popular No. 225  
Regenerative  
Receiving Set.  
\$75 without tubes,  
batteries, or loud  
speaker. Licensed  
under Armstrong  
Patent No. 1,113,149.  
Special circular  
11-C sent on request.

## Like a good old reliable friend

**Y**OU turn to your Tuska radio set with perfect faith, that it is always ready to be called upon. There is no fussing or coaxing—no apologies for its shortcomings. Year after year you can count upon this reliability of performance. New models will come, as in pianos and fine motor cars. But few will discard the old and buy the new for the sake of minor refinements. The Tuska represents the highest point in radio development to-day; you can buy it for the future with confidence.

The Tuska is the ideal set for busy people who want the thrills of radio without the tinkering. It is simple to operate. You turn two dials, listen, and select the exact program you want from the dozens which fill the air. Nothing is forced upon you by the limitations of your set—every broadcasting station within hundreds of miles is within the call of your Tuska. A letter from Prince Albert, Saskatchewan, Canada, says, "We have tuned in clearly over 100 stations, and most of them are more than 1000 miles away."

Tuska sets are built under the personal direction of C. D. Tuska, a nationally known radio pioneer and builder of fine apparatus. For a dozen years Mr. Tuska has been keenly critical of all radio parts and sets bearing his name. As a result, the Tuska seal is recognized as a guarantee of the most thorough New England craftsmanship—and there is no better.

*We will gladly send you the name of a nearby dealer who can show you the Tuska.*

**THE C. D. TUSKA CO., Hartford, Conn.**

**First to hear across the sea**

A Tuska Receiving Set was the first to receive foreign amateur trans-Atlantic code during the international tests.



**Tuska distance records**

During 12 years that Tuska Radio Apparatus has been in use, we have accumulated records of long-distance radio reception that have never been surpassed.

# TUSKA RADIO

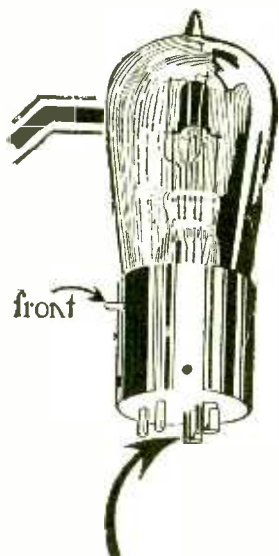

Different capacity tubes require different capacity fuses. When ordering, therefore, state exactly what tube fuses are for.

**Before It Happens**

is the time to protect your tube against "burning out" with the

**RADECO FUSE**

Patent Pending

For Vacuum Tubes

the only fuse on the market that protects absolutely against blowing the filament, even by accident. Slips directly on the filament terminal of the tube itself and does not affect the efficiency of your set. Fits in any standard socket.



**50c. each**

At your dealers or by mail

**RADIO EQUIPMENT CO.**

630 Washington Street

Boston, Mass.

"New England's Oldest Exclusive Radio House"

**DUTHO Rechargeable Storage "B" Batteries**

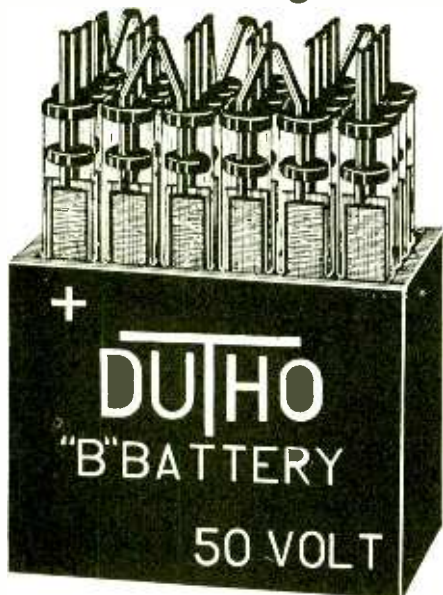

Build a DUTHO into your set: will not leak, absolutely noiseless, emits no fumes, easily recharged, large capacity, small size, will last indefinitely.

**25 Volt \$5.00**

SIZE 3"x2½"x6"

**50 Volt \$9.00**

SIZE 3"x4½"x6"

**100 Volt \$17.00**

SIZE 3"x8½"x6"

**Chemical Rectifier \$1.95**

Dealers: Write Today for our attractive Sales Proposition

½ ACTUAL SIZE

**DURKEE-THOMAS PRODUCTS CO.**

1228 Folsom St.

San Francisco, Cal.

WHATEVER YOU WANT WHEREVER YOU ARE

Let Us Get It For You

**AMSTERDAM SERVICE EXCHANGE**

Amsterdam, Ohio, U. S. A.

Radio and Cablegrams "Service"

**W.T.501 DETECTOR TUBE**

For tube sets, use our special Adaptor, 75c extra. To convert crystal sets into tube sets, use special socket, 40c extra.

Radio Research Guild  
40 Clinton Street  
Newark, N. J.



zontal wire to some point near or on the roof of a two-story house.

The actual selectivity required divides itself into two classes or conditions of service; one in which it is desired to discriminate between two relatively nearby stations of approximately equal signal strength but separated by some interval of wave-length, the other where it is desired to discriminate against a nearby station and receive from a distant one, the signal from which would, of course, be very much weaker than that from the nearby station. For the first condition, it will be found that with the average regenerative receiver, ample strength will be obtained from an antenna which is not over ten or fifteen feet high, or it may even be entirely within an ordinary living-room. The second condition, however, is a much more severe one and requires either a location where antenna of not over fifteen or twenty feet high will not be unduly shielded, or where the lesser selectivity of a high antenna will be counter-balanced by a more elaborate and selective receiving set.

**A Super-Sensitive Two Tube Receiver**

(Continued from page 262)

be found that the condenser  $C_1$  should be connected directly across aerial and ground, in which case the condenser should be taken from its present position, and the leads which went to it joined together. The dotted line in Fig. 1 shows the alternative position of the condenser  $C_1$ .

If signals are heard, but cannot be accurately tuned out on both sides of an adjustment of the condenser  $C_1$ , different coils should be tried in place of  $L_2$ , and also the condenser should be tried in the alternative position shown in the dotted line.

When small aeriels are used, the dotted line circuit should be employed, as it will be found that the inductance  $L_2$  should be a No. 50 honeycomb or equivalent.

When regeneration is used, the coil  $L_1$  may be made to couple more tightly with  $L_2$ , and a readjustment of the condensers  $C_1$   $C_2$  will be found necessary. It may also be necessary to adjust the filament rheostat. If the feedback coupling is tightened too much, a buzzing noise will probably be produced. The circuit, generally speaking, is remarkably free from undesirable low-frequency oscillations, and, in this respect, differs from many other circuits having specially sensitive qualities. If the buzzing is to be prevented, the resistance  $R_1$  may be reduced to, say, 70,000 ohms or 50,000 ohms.

It will be found that the set, arranged as described, is very stable, and the speech obtainable from it is very pure. A minimum number of adjustments are provided, and the circuit is very reliable. At the same time, it is not desirable to deviate materially from the instructions given here, as otherwise the set will howl loudly. One of the main advantages of this circuit is that a natural tendency to howl is suppressed without sacrificing signal strength.

**Station 9ZT**

(Continued from page 274)

satisfaction in knowing that a good ground will not help in this particular instance.

The transmitter consists of one UV-204 Radiotron supplied with A.C. on the filament and rectified A.C. on the plate. An electrolyte rectifier of 120 jars is located in the basement immediately under the station. The transformers for supplying the A.C. to



# A New and Unusually Good Plug

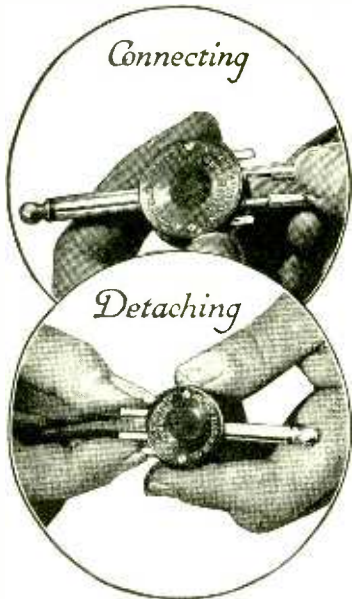

A radio plug originally designed for our own exclusive use—that has satisfied the critical demands of our own experimental laboratories—now offered to all Radio experimenters.

The simplest and quickest to operate—no tools required—no broken fingernails—assures perfect contact.

To connect, just shove terminals in—to disconnect, press the triggers and pull terminals out.

A unique design. Highest class workmanship and finish. Made with the customary Weston care. Individually tested before shipment.

Try one and see if this plug is not indefinitely superior to any plug you have ever used.

**Sent Post Paid for \$1.00**

**Weston Electrical Instrument Co.**  
173 Weston Avenue Newark, N. J.



PATENT APPLIED FOR

## THE FAVORITE Radio Cabinet

makes a high class Radio Instrument. It operates any good hook-up.

With one vacuum tube it operates a loud speaker. No loop, no aerial, no ground, or other attachments necessary. It fills all vacancies.

THE FAVORITE has won the heart of the nation. Everybody who sees it, want one and those who have the price, buy one.

It is a beautiful piece of household furniture and adds to the appearance of the finest home.

A FAVORITE in operation on the floor of a dealer attracts all the attention of his customers. Write for descriptive matter and prices.

MANUFACTURED BY

**G. A. BARTHOLOMEW**

409 Guardian Building

Cleveland, Ohio

### PHANTOM - CIRCUIT

Build Your Own. This marvel of mystery, using no loop, no aerial and no ground brings in music instead of interference. We have heard stations 950 miles distant on one tube. By using WD-11 tube set can be entirely self contained. Very easy to build from our instructions, use your own spare parts, nothing complicated like radio frequency or super regenerative. Only one tuning control. Complete instructions, with hookup and photo of circuit mailed to you for 60 cents. Stamps accepted. Vesco Radio Shop Box RN-704 Vacaville, Calif.

### FADA RADIO HANDBOOK

10¢

T-E-L-L-S the "how" about Radio receiving. Worth its weight in gold to every radio fan. Send your dime.

F. A. D. ANDREA, INC.  
1581-A Jerome Ave., N.Y.C.

FADA RADIO EQUIPMENT

the rectifier are also located in the basement.

The filter system is made up from 20 UV-490 condensers, and one filter reactor.

The circuit in use at the present time is a Hartley, giving radiation of 6 amperes on 100 meters, 10 amperes on 200 meters, and 10 amperes on 375 meters.

A large size oscillating transmitter for use in the Meissner circuit is under construction at the present time, and more radiation is anticipated, with this new inductance.

It is very easy to change from sending to receiving, as one short action switch completes the entire operation by one slight movement. A break-in system was tried, but found to be impractical on such a high power.

The receiving set is the usual single circuit design, utilizing two wave traps, one in series with the antenna, and the other coupling the antenna to the single circuit set. This arrangement has proven most successful, in view of the fact that there are some 200 transmitting stations in the immediate vicinity, and some dozen or so high power within a few blocks.

A short vertical single wire 50' over all in length is used, for receiving, as it proves extremely selective, and in addition makes an excellent antenna for work on 100 meters.

A wavemeter is used to check both receiver and transmitter, and at the time the picture was taken, as is usually the case a new type of receiving set was under the process of construction. This can be seen at the left of the picture, under the stack of cards received.

The transmitter is connected for use as a phone station by means of the magnetic modulator, if desired.

The operator has been in the commercial service with the old Marconi Company, the Navy, and at present holds a first class, first grade commercial license. The station is an official American Radio Relay League station. A schedule was maintained for two weeks with IQP before dinner in the evening. This was a very reliable schedule, as can be vouched for by the assistant editor of QST.

9ZT has a very pleasant operating atmosphere, and is open for relay work during a portion of practically every night between the hours of midnight and 7 A. M.

D. C. WALLACE.

## Radio to Play Important Part in Polar Expedition

(Continued from page 275)

grams of all new lands and harbors and lands found and charted.

The sending station on the *Bowdoin* has been assigned by the Government the call letters WNP, "Wireless North Pole." The Government has assigned wave-lengths of 200, 300 and 400 meters and has also given permission for Station WNP to use whatever wave-length it may find necessary for experimental purposes.

The American Broadcasting Station which will be used to send messages to Dr. MacMillan is the new broadcasting station WJAZ, which incidentally is the most powerful broadcasting station in the country, having a 10-kilowatt input. This station will not only be used to give Dr. MacMillan and his crew of seven entertainment and news of the day, but it will also be used by the families of Dr. MacMillan and his crew when they desire to send messages to those aboard the *Bowdoin* in the frozen North.

### SCIENTIFIC FACTS PERTAINING TO RADIO THAT WILL BE DEVELOPED

Dr. MacMillan on his expedition primar-

# SUPER-HETERODYNE RECEIVER NEW ADVANCED MODEL "C"

The Ideal Receiver for Long Distance Broadcast Reception

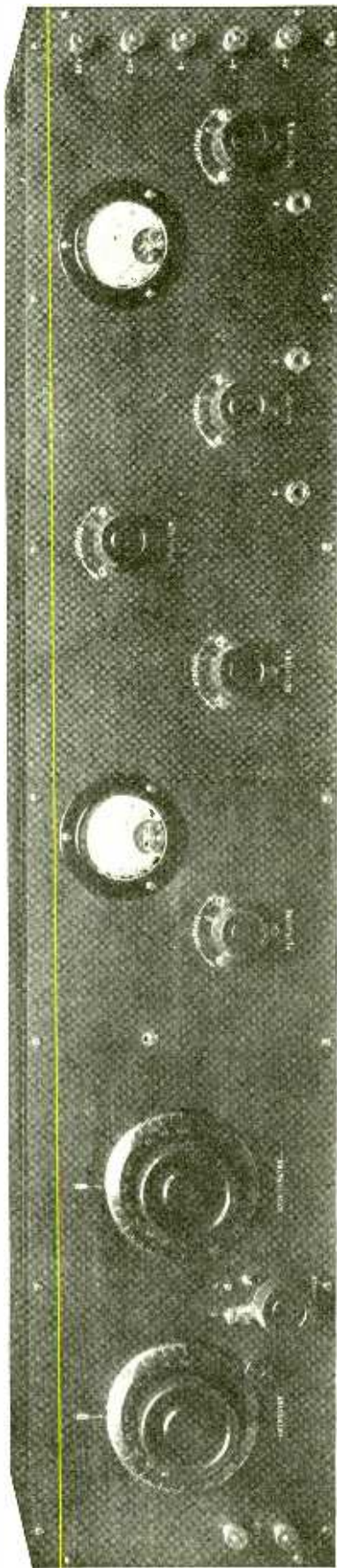

Model "C" Super-Heterodyne. Wave-length Range 160 to 850 Meters. Dimensions 40"x8"x7<sup>3</sup>/<sub>4</sub>". Weight 42 lbs.

**Simplicity**—Only 2 variable dials for all wave-lengths between 160 and 850 meters

**Efficiency**—Uniform maximum radio frequency amplification over the entire wave-length range

**Range**—2000 mile night range using Radio Corp. loop, corresponding increase with good antenna

**Selectivity**—Most selective method of reception known, works completely through local broadcasters

**Tubes**—Use UV201A or UV199 throughout, 3 stages tuned radio, 2 stages audio, 2 detectors, oscillator

*Learn More About This Remarkable Receiver. Write for Catalog 73*

**Experimenters Information Service** 531 WEST 46th STREET  
NEW YORK CITY

Designers of the Highest Class Radio Apparatus in the World

# ATWATER KENT

RECEIVING SETS AND PARTS  
are ideal for summer use due  
to their compact and rugged  
construction and the fact  
that they are moisture-proof.

Send for the illustrated folder

ATWATER KENT MFG. COMPANY  
4943 STENTON AVE. Radio Dept. PHILADELPHIA

Makers of  
THE WORLD'S HIGHEST GRADE IGNITION  
STARTING AND LIGHTING

## A Convenience That Becomes a Necessity for Maximum Pleasure in Broadcast Reception

A Radio Set with fixed antenna connections is not portable, but a very satisfactory extension set may be easily constructed with L'Radio Jacks and a little panel stock.

The extension set can be placed in the most suitable location in the living room, sunporch, or veranda and flexibly connected to the receiving set by a cord with L'Radio Plug attached.

It is most convenient then, to plug in only the headphones needed, and the extra headphones kept in some accessible place to be available as required.

At the exceptionally low price of L'Radio jacks and plugs, portability and freedom of "listeners in" from being huddled together in a space governed by a six foot cord, may be obtained at a small outlay of money and time.

Insist on L'Radio Jacks for your extension set and L'Radio Plugs for your headphone cords.

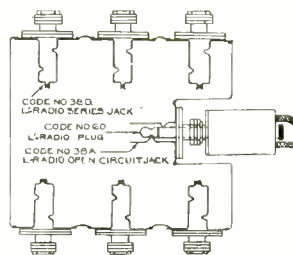

Connect Jacks as Per Diagram



No. 6 L'Radio Plug, Price 90c.

Buy them from your dealer if he has them, if not, order direct at prices listed, post-paid.



No. 38-D L'Radio Series Jack, Price 50c.

**LEICH ELECTRIC CO.**  
GENOA, ILLINOIS

Manufacturers Non Tune Radio Rectifier, L'Radio Headphones

### LET RADIO EXPERTS BUY FOR YOU

**THIS SERVICE IS FREE**  
Why hunt from store to store? Save time, trouble and money—a group of Radio Experts in New York will act as your personal Representative, buy for you any standard make of radio equipment you want, from the smallest part to a complete set, either assembled or unassembled, and deliver it to you prepaid—all for less than if you did your own buying. Satisfaction guaranteed. Also disinterested advice on all radio problems—free. Write for plan.  
**PERSONAL SERVICE PURCHASING BUREAU**  
505 Fifth Avenue Desk 15 New York

### FREE

Complete price list of radio parts.

Write Aitken Radio Co.

504 Superior St., Toledo, Ohio

ily intends to study terrestrial magnetism. He will also co-operate with the Weather Bureau and Professor V. B. Ekerold, the distinguished Norwegian meteorologist who helped establish the wireless weather station at Jan Mayen Island off the coast of Greenland. Dr. MacMillan is also conducting some investigations for the Carnegie Institute of Washington.

#### ADDITIONAL HUMAN INTEREST MATERIAL

No end of interesting material can be developed to supplement the facts above cited, particularly regarding the nature of the news stories which MacMillan will send out, the walrus hunts, the Eskimos dancing to the music of the United States, et cetera, et cetera. It will be interesting also to let one's imagination play on such situations as the broadcasting of the returns of the Presidential election and their almost instantaneous reception. Even though MacMillan and his crew of seven men will at that time very likely be within a few miles of the North Pole, they will have the news at practically the same instant that it is being received by their friends lounging at their ease in their downtown clubs. MacMillan intends to be in the Arctic only 14 months on this trip, but incidentally when he headed the Crocker Land Expedition in 1913 he intended to be gone only one year, his ship became icebound and he could not get free nor back to civilization until 1917. On his return he and his crew got their first news of the World War.

### The Ten Watt Set At 6G1-6XAH

(Continued from page 280)

outside turns are 17" in diameter. The inside turns are 7" in diameter. There are 27 turns of 3/8" No. 20 brass ribbon on both primary and secondary, enabling the set to have the wide wave-length range of from 100 to 600 meters. The five arms upon opposite sides of which are fastened the primary and secondary are secured to the centerpiece which is 6" in diameter and 3/4" thick by which the O. T. is supported. On this centerpiece is mounted the wave-length change switch. This switch facilitates the ease with which traffic may be disposed, as no time is wasted in tuning, when changing from one wave-length to another.

A loop of heavily insulated wire is fastened around the outside of the O.T., to which the microphone is connected for voice transmission. This loop modulation has been very good and is no trouble or fuss, and gives perfect modulation.

The outlay of the set may be seen in the picture.

The M.G. set is on the floor directly beneath the power panel upon which is mounted the main power switch and the two field rheostats. The filter is on the shelf behind the power panel.

The filament transformer, by-pass condenser and rheostats are mounted under the table. The knobs of the rheostats project through the table in front of the instrument panel.

The key is on the extreme left of the set, and is in the center filament tap lead.

Next is the small snap switch which turns on the M.G. and the filaments. As a separate antenna is used for receiving, this snap switch is the only one which must be manipulated to put the set into sending position.

The small instrument panel contains the home made filament voltmeter and the reconstructed plate milliammeter. The radiation meter (which is also home made) is on the left of the O.T.

All the low tension circuits were wired with No. 8 rubber covered wire. The high



# "AMERICA'S LARGEST RADIO STORE"

## OFFERS MID-SUMMER

# REAL RADIO BARGAINS

|   |                            |                |
|---|----------------------------|----------------|
| <b>\$10.00 Value</b>                                    | <b>LONG RANGE HEAD SET</b> | <b>\$3.65</b>  |
| Type C Baldwin Phones                                   | .....                      | \$6.95         |
| 2 gang Sockets  | .....                      | 95c            |
| Unit  | .....                      | \$3.95         |
| Electric Soldering Iron                                 | .....                      | <b>\$2.45</b>  |
| 1 Year Guarantee  | .....                      |                |
| John Firth Sockets                                      | .....                      | 35c            |
| 2 gang Sockets  | .....                      | 65c            |
| 3 gang sockets  | .....                      | 95c            |
| Original Nathaniel Baldwin Phones                       | .....                      | \$9.95         |
| Units   | .....                      | \$4.65         |
| Valley Charger  | .....                      | <b>\$15.95</b> |
| Variometers   | .....                      | \$1.95         |
| Variocouplers   | .....                      | \$1.75         |
| 11 Plate Condenser                                      | .....                      | \$1.35         |
| 23 Plate Condenser                                      | .....                      | \$1.45         |
| 43 Plate Condenser                                      | .....                      | \$1.75         |
| 11 Plate Condenser Vernier                              | .....                      | \$2.95         |
| 23 Plate Condenser Vernier                              | .....                      | \$3.45         |
| 43 Plate Condenser Vernier                              | .....                      | \$3.95         |
| WR-21 Tubes   | .....                      | \$2.95         |
| Branch Lightning Arresters                              | .....                      |                |
| Indoor Type   | .....                      | 95c            |
| Outdoor Type  | .....                      | 1.45           |
| Pacent Plug   | .....                      | 50c            |
| Genuine Mahogany 5 Ply Veneered Cabinet with Hinged Top | .....                      | <b>\$2.95</b>  |
| 13 1/2 x 9 1/2 x 9 1/2                                  | .....                      |                |
| Pathe Loud Speaker                                      | .....                      | \$17.50        |

## BUILD YOUR OWN SETS

Panels on all sets drilled without additional charge. Instructions for assembling and wiring included with sets.

### COMPLETE PARTS FOR

## Hazeltine Neutrodyne Circuit

Including Drilled Panels and Complete Instructions for Assembly and Wiring. All parts licensed. **\$28.60**

## Capt. R. C. Schoonhoven's 3 Tube Portable Set

Ideal for Camper or Tourist. Consists of

- |  |  |
|--|--|
| <ul style="list-style-type: none"> <li>1 13 1/2 x 9 1/2 x 3/16 Formica Panel (drilled)</li> <li>1 1 1/2 x 1 1/2 x 3/16 Formica Panel</li> <li>5 Ply Veneered Genuine Mahogany with hinged cutout top</li> <li>1 "Carter" Battery Control switch</li> <li>2 "Carter" No. 105 Fil. Cont. Jacks</li> <li>1 "Carter" No. 103 Fil. Cont. Jack</li> <li>4 "Carter" Imp. Jacks</li> <li>3 "Howard" 10 Ohm rheostats</li> <li>2 "Howard" Potentiometer</li> <li>2 "Howard" Switch Levers</li> <li>14 Contact Points</li> <li>1 Switch Stops</li> <li>5 Binding Posts</li> <li>1 23 Plate Ver. Variable Cond.</li> <li>1 "Ray Coils" Spiderweb Induct.</li> </ul> | <ul style="list-style-type: none"> <li>3 1V-199 Bakelite Sockets</li> <li>1 Tubular Grid Leak</li> <li>1 Tubular Grid Cond.</li> <li>1 Grid Leak and Cond. Mounting</li> <li>1 "All American" 10 to 1 Trans.</li> <li>1 "All American" 5 to 1 Trans.</li> <li>3 "Red Seal" Dry Cell Batteries</li> <li>2 2 1/2 Volt "B" Batteries</li> <li>25 Tinned Wire</li> <li>1 Sheets of Blueprinted Instructions for Assembling and Wiring</li> </ul> |
|--|--|

**Buy It and Build It \$29.85**

|   |       |               |
|---|-------|---------------|
| Gold Grain Detectors                                | ..... | \$ 9.50       |
| Type R-3 Magnavox                                   | ..... | \$24.45       |
| Western Electric 10-D Loud Speaker Complete         | ..... | \$28.45       |
| B Batteries, Large Size                             | ..... | \$1.65        |
| Thordarson High and Low Ratio Transformers          | ..... | \$2.45        |
| Pacent Jacks  | ..... |               |
| Single Circuit                                      | ..... | 25c           |
| Double Circuit                                      | ..... | 50c           |
| Bakelite Dials                                      | ..... | 25c           |
| Rehnartz Coils Silk Wound                           | ..... | \$1.95        |
| Loop Aerial   | ..... | \$5.95        |
| Western Electric Phone                              | ..... | \$7.95        |
| Western Electric Phonograph Receiver                | ..... | \$9.85        |
| 2 Coil Mounting                                     | ..... | \$2.95        |
| 3 Coil Mounting                                     | ..... | \$3.95        |
| Head Bands  | ..... | 50c           |
| Phone Cords   | ..... | 50c           |
| Double Tubular Mounting                             | ..... | 50c           |
| Single Tubular Mounting                             | ..... | 35c           |
| Tubular Grid Cond.                                  | ..... | 75c           |
| Tubular Grid Leaks                                  | ..... | 25c           |
| Binding Posts                                       | ..... | 5c            |
| Federal Jacks                                       | ..... | 35c           |
| Single Circuit Fil. Control                         | ..... |               |
| Double Circuit Fil. Control                         | ..... | 50c           |
| John Firth Genuine Solid Mahogany Cabinet All Sizes | ..... | <b>\$2.95</b> |
| Bus Bar Wire, two feet                              | ..... | 5c            |

### COMPLETE PARTS FOR 2 STAGE AMPLIFIER

Can be used to amplify Ultra-Audion Reinartz, Flewelling, knocked down short wave receiver, crystal or any receiving set so that loud speaker or phonograph can be used in place of headset. (Consisting of:

|  |           |
|--|-----------|
| Reg. Price   | Our Price |
| 1.05 7x10 Formica Panel (Other suitable size)          | \$ .80    |
| 4.75 High Ratio All-American or Thordarson Transformer | 3.95      |
| 4.50 Low Ratio Thordarson or All-American Transformer  | 2.95      |
| 2.20 2 Howard Rheostats                                | 2.00      |
| 2.00 2 Remler Bakelite Sockets                         | .90       |
| 3.00 3 Double Pacent Jacks                             | 1.50      |
| 1.30 13 Binding Posts                                  | .65       |
| .30 Baseboard for Mounting                             | .15       |

**\$20.00 OUR Value PRICE \$12.45**

### ULTRA-AUDION CIRCUIT

|  |           |
|--|-----------|
| Reg. Price                                 | Our Price |
| 1.12 9x10 1/2 Formica Panel (Consisting of | \$1.20    |
| 3.30 23 Plate Condenser                    | 1.45      |
| 1.00 Bakelite Socket                       | .45       |
| 3.00 Special Ultra Audion Rheostat         | 1.95      |
| 1.50 1 Howard Vernier Rheostat             | 1.35      |
| 1.50 CRL Grid Leak                         | .95       |
| 2.35 .0005 Micon Condenser                 | .25       |
| .70 2 Switch Levers                        | .50       |
| .50 18 Switch Points                       | .30       |
| .40 2 Switch Stops                         | .05       |
| .80 8 Binding Posts                        | .40       |
| 1.00 Genuine Mahogany Cabinet, 9x10 1/2    | 2.95      |
| .20 25 ft. Hookup Wire                     | .20       |

**\$19.37 OUR Value PRICE \$11.90**

### FLEWELLING CIRCUIT

|   |           |
|---|-----------|
| Reg. Price  | Our Price |
| 8.25 6x11 Formica Panel (Consisting of                              | \$1.10    |
| 3.30 23 Plate Variable Condenser                                    | 1.45      |
| 3.00 Three .006 Micon Condenser                                     | 2.25      |
| 1.85 CRL Variable Grid  | 1.35      |
| .40 Remler Grid Leak  | .25       |
| 4.00 2 Coil Adjustable Honeycomb Coil                               | 2.65      |
| .75 50 Turn Honeycomb Coil  | .40       |
| .80 75 Turn Honeycomb Coil  | .40       |
| 1.20 2 Remler Coil Mounts with straps                               | .80       |
| 1.00 1 Remler Socket  | .45       |
| 1.50 Howard Vernier Rheostat  | 1.35      |
| 1.00 1 Bakelite 3" Dial   | .25       |
| .80 8 Binding Posts   | .40       |
| .30 1 Baseboard   | .20       |
| 1.00 1 Blueprint with Complete Instructions for Assembly and Wiring | .50       |

**\$22.16 OUR Value PRICE \$12.45**

### REINARTZ CIRCUIT

|  |           |
|--|-----------|
| Reg. Price                             | Our Price |
| 1.89 7x18 Formica Panel (Consisting of | \$1.70    |
| 1.00 Remler Bakelite Socket            | .45       |
| 1.50 Howard Vernier Rheo.              | 1.35      |
| 3.30 23 Plate Variable                 | 1.45      |
| 3.10 11 Plate Variable                 | 1.35      |
| 1.50 3 Switch Levers                   | .75       |
| .80 2 dozen switch points              | .40       |
| 3.00 1 Schoonhoven Reinartz Coil       | 1.95      |
| 1.00 Freshman Variable Grid            | .75       |
| .80 Binding Posts                      | .40       |
| .30 25 feet Tinned Wire                | .20       |
| .50 Baseboard                          | .25       |

**\$21.69 OUR Value PRICE \$11.45**

### KNOCKED-DOWN SHORT WAVE RECEIVER

|  |           |
|--|-----------|
| Reg. Price                                     | Our Price |
| 10.00 2 Variometers (Consisting of             | \$3.90    |
| 5.00 1 Variocoupler                            | 1.75      |
| 3.00 3 Bakelite Dials                          | .75       |
| 1.00 Remler Bakelite Socket                    | .45       |
| 1.10 Howard Rheostat                           | .80       |
| 5.00 Cunningham C-300 Detector Tube            | 4.45      |
| 4.50 Mahogany Cabinet                          | 2.75      |
| 2.25 Genuine Formica Panel                     | 1.75      |
| .80 8 Binding Posts                            | .40       |
| .50 Switch Lever                               | .25       |
| .40 12 Switch Points                           | .20       |
| 1.00 Freshman Grid Leak and Condenser Combined | .75       |
| 1.00 Complete Drawing for Assembly and Wiring  | .50       |

**\$30.85 OUR Value PRICE \$17.95**

### COMPLETE PARTS FOR SINGLE TUBE REFLEX CIRCUIT

|  |           |
|--|-----------|
| Reg. Price   | Our Price |
| \$5.00 Radio Frequency Transformer                           | \$3.95    |
| 7.00 43 Plate Vernier Variable Condenser                     | 3.95      |
| 8.50 Radion Loop Aerial                                      | 6.45      |
| 9.00 Cunningham C301-A Tube                                  | 5.95      |
| 2.00 Grewol Glass Inclosed Detector                          | 1.65      |
| 4.75 All-American 5 to 1 Ratio Audio Frequency Transformer   | 3.95      |
| .70 2 .001 Micon Condensers                                  | .50       |
| .15 1 .002 Micon Condenser                                   | .35       |
| 1.50 Potentiometer   | 1.35      |
| 1.10 25 Ohm Rheostat   | 1.00      |
| .80 8 Binding Posts  | .40       |
| 1.12 9x10 1/2 Formica Panel                                  | 1.42      |
| 5.00 9x10 1/2 Genuine Solid Mahogany Cabinet with Hinged Top | 2.95      |

Complete instructions for drilling, assembling and wiring so that anyone with no technical knowledge can easily follow.

**\$47.22 OUR Value PRICE \$32.65**

**Brown and Black FORMICA PANEL** Cut to Any Size 7/8" Thick 3/16" Thick 1 1/2 c. sq. inch 3c. sq. inch Panels Engraved 4c a letter

All Merchandise Purchased of Us Carries **OUR ABSOLUTE GUARANTEE** of Satisfaction



Mail Orders Receive Our Immediate Attention

509 SOUTH STATE STREET

Dept. RN-8

CHICAGO, ILL.

# "ESCO" Battery Chargers

To meet an insistent demand for RUGGED—RELIABLE NEVER FAILING MOTOR-GENERATORS. For charging Batteries in Wireless Operation. We have developed a complete line of MANY SIZES. With or without panel boards. ESCO quality thruout. You know what that means.

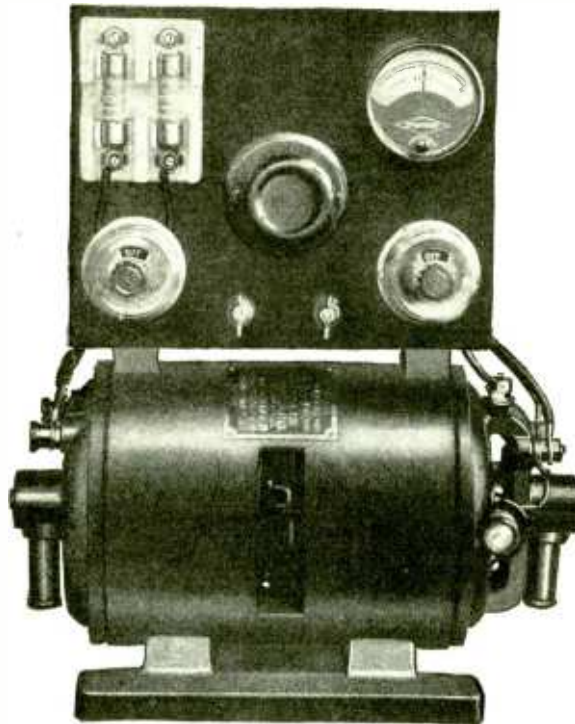

Ask for Bulletin 242

## ELECTRIC SPECIALTY CO.

211 South Street  
STAMFORD, CONN., U. S. A.  
Pioneers in Developing Quality Wireless Apparatus

# "PIONEER" Instruments

GLORIFY ANY RADIO SET

Extend Range, Clarify Reception, Minimize Discords

Shells are molded from genuine Bakelite, by ponderous special machinery in our own plant. Our special Pioneer mahogany finish has a richness unapproached by any similar instruments.

Winding of both Rotor and Stator is with heavy copper wire, covered with silk thread. Hardware is bronze, heavily nickeled.

Workmanship characterized by the highest mechanical skill and infinite attention to detail.

Design. Note that variocoupler is wound inside the shell, like a variometer, original and exclusive with us. Both instruments are close-coupled, with positive contacts.

"Pioneer" Variometer ..... \$6.50  
"Pioneer" Variocoupler ..... \$7.00

Order from your dealer or remit direct to us and give name and address of dealer you wish to favor.

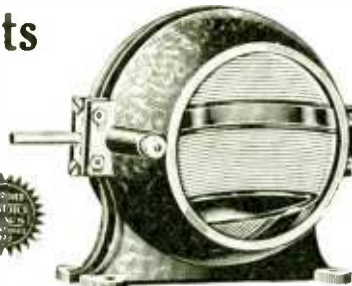

"Pioneer" Variometer \$6.50

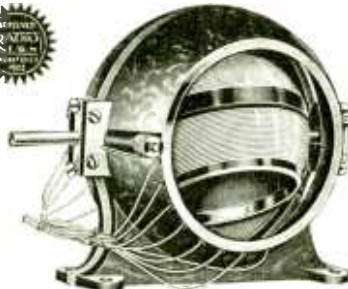

"Pioneer" Variocoupler, \$7.00

Branch Offices:

New York City, ..... 220 Fulton St.  
Chicago, Ill., ..... 33 So. Clinton St.  
Kansas City, Mo., ..... 208 Baltimore Bldg.  
Minneapolis, Minn., ..... 705 Plymouth Bldg.  
San Francisco, Calif., ..... 623 Larkin St.

**PIONEER** RADIO CORPORATION  
GALESBURG, ILL. U. S. A.  
European Branch Office: London, Eng., 27-28 Anning St.  
Gaston E. Marbaix, European Mgr.

Variable Grid Leaks ..... \$ .45 each  
Tubular Grid Leaks (all resistance) ..... .50 each  
Tubular Grid Leaks mounting ..... 35 each  
Single V. T. Sockets Type S-10 ..... 90 each  
Triple V. T. Sockets Type S-4 ..... 2.70 each  
Bakelite WD-11 Sockets ..... .50 each

RADIO SERVICE & MFG. CO.

(Established 1918)

Factory—Lynbrook, L. I.

We carry a Complete Line of Radio Apparatus

# NOVO "B" BATTERIES

WITH INSULATED BINDING PDSTS & DETACHABLE WIRE CONNECTOR

NOVO MFG CO.

424 W 33<sup>rd</sup> ST NEW YORK - 531-50 DEARBORN ST CHICAGO

tension wires are extra flexible 1/4" cable, heavily insulated.

No variable condensers are used as they reduce the efficiency considerably and are not necessary for tuning the set.

The modified Hartley circuit is used.

When radiating 3.7 amperes with 600 volts on the plates, the tubes are absolutely cool. (The fan was added to the set when I got the additional generator.)

It is well to remember that when the plates of the tubes are being overloaded it is necessary to overload the filaments proportionately or the tubes will heat.

This set has been found to be very dependable, easy to operate, and very low in cost of construction.

## Five-Watt C. W. and Phone Set

(Continued from page 281)

Now by means of a wavemeter obtained in any of the approved ways (bought, borrowed or swiped, just so you have one), see what the wave is. If it is too high move the counterpoise clip nearer the antenna and readjust the grid and plate clips first, then the condensers. Once a resonance point is obtained it is an easy matter to move to a higher or lower wave.

With the set tuned you may safely apply the full D.C. voltage. To use the phone insert the modulator tube and remove the plug in the key jack and insert the microphone plug. Light both tubes to proper brilliancy, apply the D.C. and being sure the battery is in the microphone circuit and the bias battery are connected, talk into the transmitter. This should cause a variation of the plate current and the antenna current. By varying the bias battery and the shunt across the transformer you will be able to clear up the quality of the speech. The best test is through a distant receiving station.

For calling on the C.W. it is more convenient to have a switch so as to cut out the filter and thereby let the commutation frequency modulate the output, which will make it much easier to find on the tuner, but when once found the filter may be cut back in and work done on the D.C. C.W.

The author makes no claims for originality in this set, but rather the application of economical methods and the practice of modern efficiency. Thus while perhaps the only difference in this from hundreds of other sets is in either, or both, the tuned plate choke and tuned grid choke, these, either of them, especially the latter, made a world of difference in the power input to the tubes and more difference yet in the over-all efficiency of the set. I am sure that anyone's time will be well spent in following out the design of this set as it was given a lot of careful consideration by the author before construction and there are no regrets.

As to the range I would say that the first evening that the set was operated I worked 6AUU in Frisco on C.W. and he said signals QSA so I told him to stand by for voice and then to my surprise he said voice FB and we worked thus for over a half hour. Since then the voice has been reported up and down the coast and as far east as Kansas while the D.C. C.W. has been reported from the east coast numerous times.

With the drawings, circuits and diagrams I believe there is nothing further to detail, though should any more information be desired the author will be glad to give it if a self-addressed envelope is included with the letter.

## A Panel Mounted Coil

(Continued from page 283)

the aerial binding-post connects directly to one end of the coil; this is clearly shown in the sketch. An inductance of this kind takes

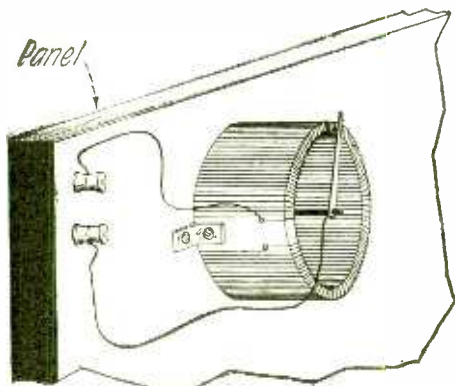

An Easily Constructed Tuning Coil for Panel Mounting. A Switch Arm Replaces the Usual Slider.

but little space on a panel and is capable of accommodating a large amount of wire. I am now using a crystal set employing this type of coil and obtain excellent results.

Contributed by C. J. Morrison.

## Correspondence from Readers

(Continued from page 285)

pieg-1); 6AOS said something about a (long way). I suppose he meant Australia; 6CQB (not sure).

May 20th. Very free from static this night and a great number of stations were heard; 7BDC calling 7ZN; 6KM calling CQ; 6ALK; 6ACM calling Australia (code word, alo); 6CDI; 6BUY; 6BDC calling 6CJJ; 6KM calling 9BX; 9ZT calling 6ASU; 6ASU calling CQ; 6CGE calling 9TO; 6DUY or 6BUY calling CQ; 6AKN calling (—); 6BEO calling 7AFN; 6BUN calling Australia; 6CBI calling 9ZT; 9BAQ calling 9BJK; 6CGW was readable with phones on the table using two-step amplifier (choke coil).

Home made DL coils, also spiderwebs, were used. DeForest condensers .0005 mfd. with a Connecticut as a vernier. The length of aerial was only 100 feet over all, 70 feet long with 30 feet down leads. Brown's headphones were used, 8,000 ohms adjustable reed type.

By the end of this week I expect to have a Beverage antenna so that I hope to log many more stations.

G. A. BRUNETTE,  
Hector St., Leatown,  
Wellington, N. Z.

### WHAT DO YOU THINK?

Editor, RADIO NEWS:

Considerable comment has been made upon DX work with a crystal set and I, for one, disagree with them.

Many say that when DX work is done with a crystal set, it receives it from some nearby tube set which is at that time receiving the distant station which is being heard with the crystal set.

I have a crystal set and in the list of stations I have heard (the total numbering 33) there are stations 900, 856, 720, 600, and 427 miles away. Every night for two or three months I could hear stations 427 miles and 720 miles, and on other occasions I have heard all of the other stations of greater distance at least twice. Some nights I have



## 18 STOCK SIZE PANELS

Radion being an insulation material especially made for wireless use, has the lowest phase angle difference, lowest dielectric constant, highest resistivity and supreme moisture, gas and acid repelling properties.

V. T. sockets, made from inferior insulating materials, have caused many radio fans endless trouble—trouble mighty difficult to locate too. Inferior insulations permit short circuits between terminals—the passage of minute electrical currents where they do damage to receiving results.

Radion, a specially made wireless insulation material, stops this trouble. It eliminates leaks of radio frequency currents where other materials fail. It is being adopted as standard by more and more radio engineers every day *because it is supreme.*

Every man assembling his own set will save annoyance and money by employing parts and panels of RADION. And they cost no more than inferior substitutes.

Write today for descriptive folder.

**Panels, Dials, Knobs, Antenna, Insulators, Etc.**

**AMERICAN HARD RUBBER CO.**

11 MERCER STREET, NEW YORK

# RADION

*The Supreme Insulation*

**RADIO SE-AR-DE PRODUCTS**

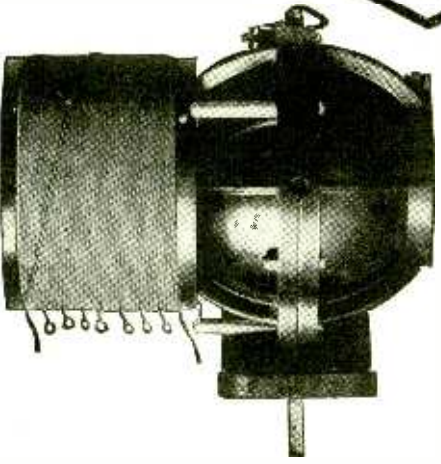

**SE-AR-DE Molded  
RADIOMETER**

*Build Your Own  
Single Circuit Tuner*

CATALOGUE No. 165

**\$13.00**

Range . . . . . 180-3100M  
" . . . . . 300-3280M

**R. MITCHELL & CO.**  
255 ATLANTIC AVENUE                      BOSTON, MASS.



**Add-A-Unit  
Line**

**A new sensible delightful way of building a radio set. Saves time, labor, money.**

Each RPM unit is complete in itself. Make any combination you wish and cross-connect by wiring output to input contacts. (Hook-up Diagram free with each purchase.) No panels to drill; no dials, knobs, contact-points, spaghetti wire or other accessories to buy.

*RPM Variometer and Variocoupler Combination*, with a Detector Unit, makes a fine working set. Add as many stages of amplification as you wish.

*RPM Amplifying Unit*. Complete, with panel. Highly efficient.

*RPM Coupled Circuit Tuner* (Mounted or unmounted.) Takes place of both Variometer and Variocoupler. A little wonder-worker.

*RPM Mounted Variable Condenser*. It cannot "short."

*RPM Loading Coil*. Electrically correct.

*RPM Base* for mounting all units, no panel necessary.

All built in our own modern plant. Rotor and Stator Shells molded from Genuine Bakelite. Very handsome.

*RPM Units*, without the panels, are also admirable for your present set. Will increase its range, clearness and tone-quality.

*Jobbers and Dealers!* The RPM line sells on its beautiful appearance; repeats on its fine performance. Send for list and discounts.

**Radio Products Mfg. Co.**  
667 West 14<sup>th</sup> St.                      Chicago, Ill.

*Quality*  
**RADIO CABINETS**

*Send for booklet and prices*

**THE ZIN-NEC-KER CO.**

Rockton, Ill.  
U. S. A.

**RADIO GOODS at BARGAIN PRICES**

|  |        |
|--|--------|
| Cunningham C-300 Tubes .....                     | \$4.39 |
| Cunningham C-301-A Tubes .....                   | 5.89   |
| W. D. II Tubes .....                             | 5.89   |
| 1½ V. Mercury Tubes, Standard Base, Best Made .. | 5.25   |
| 22½ V. Var. Cyclone B. Battery .....             | 1.00   |
| 22½ V. Var. Cyclone B. Batt. medium .....        | 1.25   |
| Large .....                                      | 1.75   |
| 45 V. Var. Cyclone B. Battery .....              | 2.95   |
| 2200 Ohm Nereo Phones .....                      | 2.95   |
| Original Nathaniel Baldwin Phones, Type C .....  | 8.95   |
| Remier Rheostats or Sockets .....                | 8.50   |
| Magnavox .....                                   | 30.00  |

Numerous other bargains in our FREE PRICE LIST, sent upon request. Goods shipped PREPAID PROMPTLY on receipt of remittance. All merchandise guaranteed.

BERGEN RADIO SUPPLY CO.  
606 Bergen Ave.                      New York City

**GREEN SEAL**

AIR-WAY RADIO Equipment appeals to the discriminating user for its genuine quality at fair prices. Write for Free Air-Way Bulletin of Complete Sets and Standard Parts. Attractive dealer proposition.

Air-Way Electric Appliance Corporation, Toledo, Ohio.

Write for free catalog illustrating and describing our complete line of 1500 Good Tools .

**GODELL-PRATT COMPANY**

*Toolsmiths*  
Greenfield, Mass., U. S. A.

heard eight stations within from three to 856 miles.

I do not think it practical that I could pick it up from other sets as not many people are hearing DX every night.

Are there any more comments upon this subject?  
ARTHUR HALL,  
Oakland, Calif.

**ABOUT AN ARTICLE**

*Editor, RADIO NEWS:*

RADIO NEWS is so well known in this country that I am surprised at your letting such an article as Mr. Sleeper's go through in your April issue, at least without a little modification.

English weather has little to do with radio, I know, but to say our street lamps are going 24 hours a day is strong, even from an American. I believe we did experience one such day this year, although I can't remember—a sure proof that it's not a common occurrence for the streets to be as black as midnight at midday. However, some one who recently returned to this country after visiting New York had just as strong remarks to make about the slush in the streets—which Yanks in New York don't seem to worry about any more than we do our fogs—so it cuts both ways.

But, of course, it was Mr. Sleeper's distorted idea of our radio position which got my goat mostly—and I hope you will publish this letter to prove that his statements were misleading, as most certainly they were.

It causes us no little amusement on this side to read of the chaos which has been caused over there by hundreds of broadcasting stations wanting the air at once. We pity the poor ham who can't afford a three-circuit tuner, and gets opera, news, market reports and lectures all at once. Is that what you call "radio development"? The very fact that every one on your side is calling for "fewer and better broadcasting stations" proves that we English people are going along the right lines. At present, five broadcasting stations are operating in this country, and further ones are being considered. A three-valve set—using H.F. amplification—will get all these. All stations transmit from 11:30 to 12:30 in the morning and between 5 and 11 o'clock in the evening—excepting when plays are broadcast from theaters, when it goes on to eleven o'clock or later.

"There isn't any radio business or any broadcasting", says your "well informed" contributor. What did he listen in on? 22,000 meters? Mr. Sleeper makes very scathing remarks about our receiving gear. Yes, it's so badly made that well over a hundred people have picked up your concerts. Can you give me the name of an American amateur who can really claim to have heard ours? The proof of the set is in the working, not the beautifully sounding name that can be given it. Our sets are classified by the gear alone. We don't call every set a "super" or some other price-fetching noun.

So much for that. The facts given above are authentic in every way, and I know I voice the indignation of all English amateurs at such statements being put before the American public. FRED G. SIDSTON,  
London, England.

**CONDITIONS IN TORONTO**

*Editor, RADIO NEWS:*

After reading of conditions in different cities, through the columns of your publication, I thought possibly you might be interested to learn of conditions in this city, with respect to the broadcast listener and the transmitting amateur.

Here we have things going on quite harmoniously, there being no friction between the two classes. The transmitting amateurs

# Federal Audio Frequency Transformer No. 226

## AMPLIFICATION WITHOUT DISTORTION

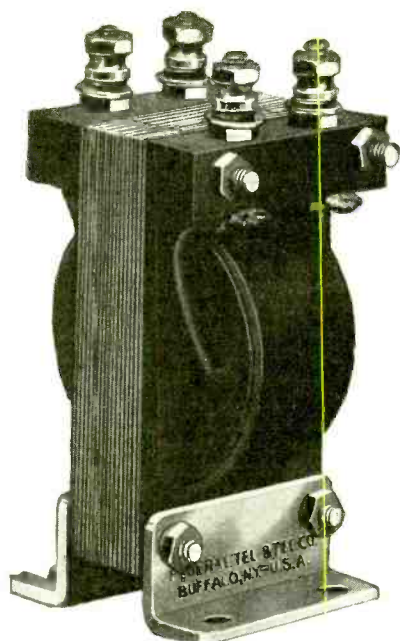

No. 226 actual size

This transformer pronounced by leading Radio engineers, after exhaustive tests, to excel in all essentials.

*Federal A. F. Transformer No. 226 can be used with any vacuum tubes in common use.*

It furnishes greater amplification and faithfulness of reproduction of both voice and orchestral music.

Install a No. 226 on your present set. It will prove a revelation to you.

Every unit guaranteed. Send today for illustrated catalog, describing them fully.

YOUR DEALER SELLS FEDERAL No. 226

**130 Guaranteed Radio Products**

**Federal Telephone & Telegraph Company**  
BUFFALO, N. Y.

# Four New MAR-CO Accessories

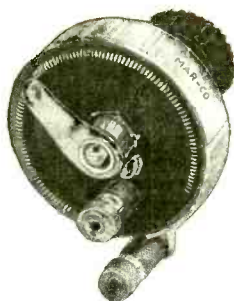

**ARMORCLAD  
30 OHM  
RHEOSTAT**

199 or 201A  
Tubes **\$1.00**



**STA-PUT  
MULTI-PLUG**

One to Four  
Headsets **\$2.00**



**199 ADAPTER**  
Fits Any  
Socket **65c.**

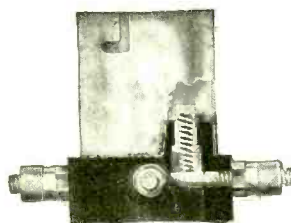

**199 CUSHION  
SOCKET**

Coil Spring  
Plunger  
Contact **75c.**



**MARTIN-COPELAND COMPANY**  
PROVIDENCE, R. I.



## Amplification Perfection

with an audio transformer means **PURE TONE QUALITY** with **MAXIMUM VOLUME**

### The AMERTRAN AUDIO TRANSFORMER



PRICE \$7

Ask your electrical dealer, or sent carriage charges collect. (Wt. 1 lb.)

is acknowledged by professional radio engineers to be the standard of excellence for audio amplification.

The reason for the popularity of the AmerTran among professional radio men is apparent in the Amplification Chart shown in our Circular No. 1005.

Turn ratio, 5:1. Amplification ratio, 30-40 times audibility in the flat part of the curve.

## American Transformer Company

Designers and builders of radio transformers for over 20 years

177 Emmet St., Newark, N. J.

## "UNITED" Radio Instruments Will Multiply the Joy of Your Radio Evenings

Our new million dollar plant with its unequalled equipment of precision tools and our staff of trained radio experts have enabled us to develop condensers and transformers which offer

- 1—Finer tuning, under more perfect control.
- 2—Clearer reception, from any distance.
- 3—Welcome freedom from discordant noises.

"United" Audio-frequency Amplifying Transformer Magnetically shielded, Ratio 5 to 1. Price \$4.50.

"United" Variable Condensers, with new Vernier.

Dial Adjuster

|                 |                 |                |
|-----------------|-----------------|----------------|
| 43 plate \$6.50 | 11 plate \$5.50 | 3 plate \$4.75 |
| 23 plate 6.00   | 5 plate 5.00    | Postpaid       |

Try your Dealer First. If he does not carry the line, remit to us and give us his name and address.

**UNITED MFG. & DISTRIBUTING CO.**

9705 COTTAGE GROVE AVENUE

New York Office:  
50 Church St.  
New York, N. Y.

CHICAGO,  
ILL.

San Francisco Office:  
709 Mission St.  
San Francisco, Cal.

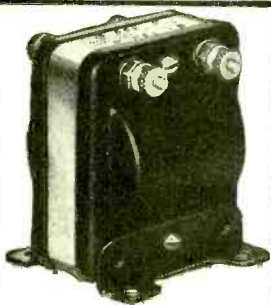

## TWO SUPERSENSITIVE CIRCUITS

(Both Copyrighted)

My Highly Improved Reinartz brings in all important stations on both coasts and Mexican border, loud, clear and without distortion. We dance to music from Atlanta received on one loud Baldwin unit. Build one of these wonderful sets from my blueprints and specifications, price 50c, or with a perfect and complete double wound spiderweb coil, \$3.00 by mail. No other windings used. Photo of my set on a glass panel with every order.

My W. D. 11 Circuit is especially designed for use with the "Pickle" tube and brings out the full value of that little tube as no other circuit can. Stations 1000 miles away come in clearly on one tube. This set is small, complete, portable. For the man who wishes the highest efficiency this is the set to build. Price of blueprint and specifications 50c, or with complete and perfect windings \$3.00. Photo of set with every order. Either set is cheap and easy to build, easy to operate. Everything clearly shown.

S. A. Twitchell, 1927 Western Ave., Minneapolis, Minn.

## Chelsea Regenerative Equipment

Licensed Under Armstrong U. S. Patent  
October 6, 1914

Write for Bulletin No. 7

CHELSEA RADIO COMPANY, CHELSEA, MASS.

## RADIO SCHOOL

All our graduates are placed.  
Shortage still exists.

Send for Catalog

**MASSACHUSETTS RADIO & TELEGRAPH SCHOOLS Inc.**

18 Boylston St. Boston, Mass.  
C. R. ENTWISTLE, Radio Director

## KILLOCH HEAD SET

2000 OHM \$3.25 POSTPAID IN U. S. A.  
Baldwin Head Set \$8.75 Postpaid in U. S. A.  
Send For Radio Catalogue

DAVID KILLOCH CO., 57 Murray St., N. Y. City

stand by from 7:00 p. m. till 10:30 p. m., to allow the others to hear the concert programs from the various stations. In this way, though there are some 30 amateur C.W. stations, actively transmitting, some of which have been heard several thousand miles, and most others heard several hundred miles, there is very little local interference. Of course, there may be a time when somebody may be a little thoughtless and transmit when he should stand by, but he only bothers those stations in his immediate vicinity.

The local amateur association, the Wireless Association of Ontario, has a service committee composed of several of the most experienced amateurs in the city who volunteer their services gratis to the new and consequently less experienced broadcast listener who may have difficulty with his set or seeks advice regarding the building or installation of new equipment. In this way the old amateur is giving his time and experience for the love of the game. As you will doubtless appreciate, this alone should help prevent any bad feeling between the phone listener and the relaying amateur.

The W. A. O. O. is doing its utmost to show the "B. C. L." that the amateurs are not a crowd of thoughtless little boys in short pants but real live young men who can be of service to them. This association has about 150 members, the greater number of whom are telegraphing amateurs. This is the largest local association. There are three other radio research clubs in the city.

Amateurs in Toronto have very little difficulty in getting any kind of equipment they require, as practically all lines of radio supplies are handled. There are several quite large houses, as well as three large department stores, which carry large stocks of equipment, not to mention any number of smaller stores.

The largest local broadcasting station is CFCA of the Toronto *Daily Star*, which has excellent programs. In addition to this, Toronto is favorably located for DX reception. This winter alone, the writer has heard over 55 American broadcasting stations on one tube.

VICTOR LASCALLES,  
Toronto, Canada.

## RADIO MERCHANDISING

Editor, RADIO NEWS:

It may be of interest to your readers to know that the Y. M. C. A. radio school is preparing to establish a class in "Radio Merchandising." This course will be planned especially for the small radio dealer and the newcomer into the radio retailing and merchandising field. It will consist of 15 sessions and the class will meet two or three evenings a week. Organizing and planning the radio store will be covered fully. The training of radio salesmen, the establishment of amateur club rooms, the demonstration of a radio set, dressing the radio store window, financing the radio store, selecting radio stock and many other phases of the radio business will be included.

The course will be short, making it possible for the busy radio clerk or business man to find time for attendance. An important feature is that entrance may be made at any time, the lectures and practical demonstrations being so arranged that it will be unnecessary to start at the beginning, and perfectly practical to accept a student even though part of the course has been covered. The student who enters late can wait and take the part he has missed with the next class.

The course is strongly backed by all the radio manufacturers and dealers thus far approached, the most important of which is the Radio Corporation of America.

(Continued on page 329)



# 3 NEW POPULAR RADIO PATTERNS

These three additions to the "Radio Constructor Series" comprise full size working diagrams and complete instructions for building three of the most popular radio sets now in vogue.

**PACKET No. 4**  
**How to Make a Reinartz Receiver**

**PACKET No. 5**  
**How to Make a Reflex Receiver**

**PACKET No. 6**  
**How to Make a Cockaday Receiver**



Each Packet  
Complete

## 50c

Each packet contains complete instructions for the construction of these circuits including the tools required, parts needed, directions and pattern for drilling, mounting and wiring and most important of all, full instruction on how to tune the circuit. Sets constructed from these plans have been thoroughly tested and pronounced perfect.

## 4 NEW SUPPLEMENTS 4

To the Famous 20 Radiophone Diagrams and Hook-ups



This Packet, Complete  
with  
4 New Supplements

## 50c

Order From Dealers Whose Names Appear on Page 352

If Your Dealer Cannot Supply You, Send Us His Name and Address

We could not improve the ones we already had but to live up to our policy of keeping our plans and diagrams up to date we added in sheet-form the COCKADAY CIRCUIT, REFLEX CIRCUIT, REINARTZ CIRCUIT AND NEUTRODYNE CIRCUIT. The other circuits in this series are:

1. Single Slide Tuning Coil with Crystal Detector.
2. Double Slide Tuning Coil with Crystal Detector.
3. Loose Coupler with Crystal Detector.
4. Regenerative set, using 2 slide tuner.
5. Plain Audion Detector Circuit.
6. Feed-back Circuit with a loose Coupler.
7. Armstrong Feed-back Circuit.
8. Standard Short Wave Regenerative Set.
9. Honey-comb coil Receiver for all wave lengths.
10. Short Wave Regenerative set, with 2 step amplifier.
11. Combination Circuit for Long and Short Wave.
12. Detector and Two Stage Amplifier with automatic Filament control Jacks.
13. Single Circuit Regenerative Tuner.
14. Circuit for elimination of induction from power lines.
15. Loop Aerial Receiver.
16. Radio and Audion frequency amplifier.
17. Circuit of a C.W. Transmitter for low power.
18. 5-Watt Radio-phone.
19. 10-Watt Phone and C.W. Transmitter.
20. High Power CW. Transmitter.

In addition to the above connection diagrams, the packet also includes a four-page instruction pamphlet, explaining each diagram in detail, also, "HOW TO READ DIAGRAMS" — "HOW TO FOLLOW CIRCUITS" and, A COMPLETE KEY OF THE MOST COMMONLY USED RADIO SYMBOLS.

*The Conrard Co.*  
INC.  
Formerly the  
Consolidated Radio Call Book Co.  
233 Fulton St.,  
New York City





# "RICO" LEADERS



## The "Rico" TUNED Melotone Speaker

The "RICO" TUNED MELO-TONE SPEAKER is not a make-shift, not a toy, but a high grade scientific instrument, built in very large quantities in order to give the public the advantage of our low-manufacturing costs.

These are the specifications:  
 Adjustable and tuned "RICO" Loud Talker, fitted in cast metal base, handsomely finished, with two coats of baked enamel;  
 Nickel-plated and polished gooseneck;  
 Full fibre horn;  
 Five-foot attachment cord.



MELO-TONE TUNED Loud Speaker

So remarkable is this adjustment, and so wonderfully exact does it work, that any sound volume or quality can be readily obtained. It is in your power to TUNE the MELO-TONE SPEAKER in such a manner that if you wish a moderate amount of sound you can readily obtain it, or if you wish volume, as, for instance, band concerts, the adjustment can be made instantaneously. To make the adjustment simply screw the case within the base of the speaker slightly backward or forward. No screws, no nuts, no fussing, no damaged diaphragm.

### The Tuned Feature

Our cross-section diagram shows our new adjustable feature, by which it is possible to make this loud talker give out almost any sound within reason. The MELO-TONE SPEAKER can not possible shatter nor rattle under any circumstances.

The new development comprises a specially-formed, pure Para Rubber Gasket, accurately made, upon which the diaphragm rests. By tightening or loosening the shell of the receiver its diaphragm approaches or recedes the desired distance toward or away from the pole pieces.

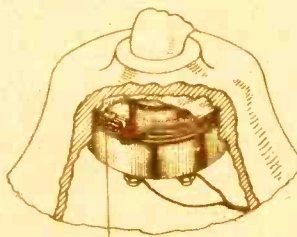

RUBBER GASKET

### Acoustic Features

After you have listened to all of the expensive loud talkers, all we request is that you give ours a trial. You will find that it compares favorably with the most expensive loud speakers on the market.

### "Rico" Tuned Receivers

The greatest development in radio telephone receivers in a decade. Rico tuned receivers (patents allowed) are the only practical tunable receivers on the market. Each phone has a pure para rubber gasket which is compressible so as to move the diaphragm to and away from the pole piece. By means of this arrangement it is possible to achieve a super-sensitivity not possible with other phones. Temperature changes are equalized due to the adjustability and you can adjust your phones for a hot or a cold day. This feature is particularly valuable for long distance work, and when phones are used for hours at a time. Rico tunable phones can be adjusted for crystal work or for three stage amplification on a tube set, at your wish.

Order from us or direct from your dealer. Fastest selling phones in America.  
 No. 20 2000 ohms tuned double head set. . . \$6.00  
 No. 30 3000 ohms tuned double head set. . . \$7.00

### "Rico" Phonodapter

Single Phono-dapter 75c



This adapter fits Columbia, Victor and Sonora phonographs. Is made entirely of pure rubber with brass tube insert.



TO TUNE—TIGHTEN OR LOOSEN CAP SLIGHTLY

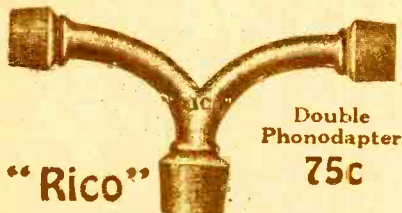

Double Phonodapter 75c

### "Rico" Double Phonodapter

A pair of receivers plus this adapter make your phonograph a loud-talker. The "RICO" Phonodapter presents many unique advantages over other similar adapters. It does not give rise to echoes, as is the case with most of the others that we have examined. There are no echo air chambers left after the adapter is attached to the phones, as is the case with so many others. The body of our double Phonodapter is of cast metal, nickel plated and highly polished. Three generous soft rubber bushings; will fit any make phone. No. 132 "RICO" Double Phonodapter, as described, each, prepaid \$ .75

### SEND NO MONEY USE COUPON BELOW

Note: The "RICO" TUNED MELO-TONE Loud-Speaker No. 250 'Phone must be used in connection with a 1- or 2-stage amplifier or more.

### SEND NO MONEY

COUPON R. N.-9

Radio Industries Corporation  
 131 Duane Street, New York,  
 Gentlemen:—Please send me by Parcel Post . . . "Rico" . . . for which I will pay the postman the amount of . . . plus charges.

Name . . . . .  
 Street and No. . . . .  
 City . . . . . State . . . . .

**RADIO INDUSTRIES CORPORATION**

131 Duane Street, New York City

Cable Address: Ricotrade, New York.

Chicago Distributor  
 Triangle Electric Co., 160 W. Lake St., Chicago, Ill.  
 Detroit Distributor  
 Kopley & Ross, 1244 Randolph St., Detroit, Michigan

CIRCULATION 60,000 COPIES

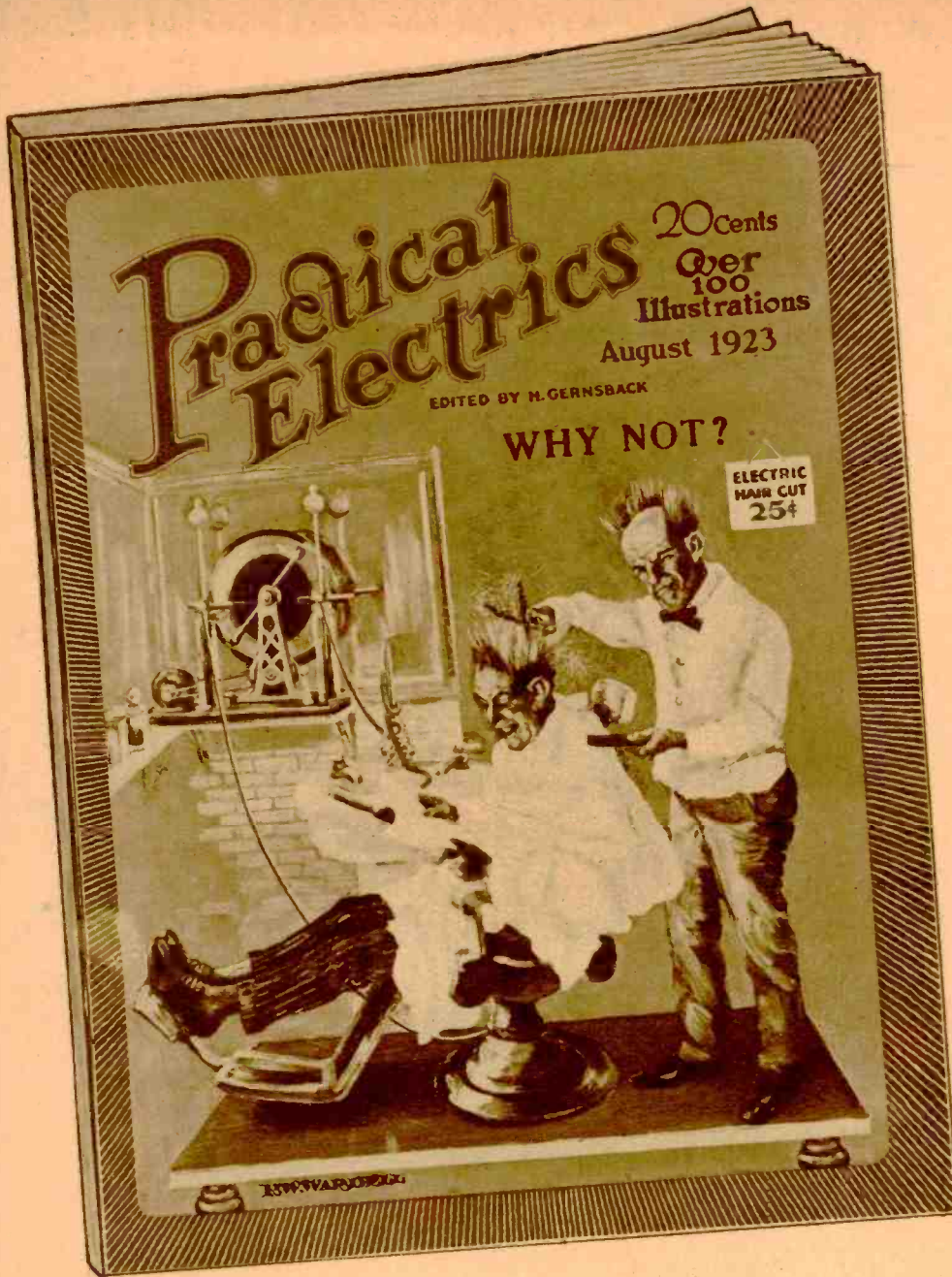

This magazine is edited by  
**H. GERNSBACK**  
also Editor of  
**RADIO NEWS**  
and  
**SCIENCE and INVENTION**

100 Articles  
Over  
100 Illustrations

FOR SALE AT  
ALL NEWS STANDS

20c. the Copy  
**\$2.00 a Year**  
Canada and Foreign  
**\$2.50 a Year**

SEND FOR  
**FREE**  
SAMPLE COPY  
TODAY

See Coupon Below  
for **SPECIAL OFFER**

# "The Electrical Magazine for Everybody"

**P**RACTICAL ELECTRICS is probably the most novel magazine of its kind ever conceived. It is personally edited by H. Gernsback, editor of SCIENCE & INVENTION and RADIO NEWS. Mr. Gernsback, who founded the old "Modern Electrics" as well as the "Electrical Experimenter," knows thoroughly what his readers want and have wanted for many years. PRACTICAL ELECTRICS, the 100% electrical magazine eclipses the best that was in "Modern Electrics" and "Electrical Experimenter."

Electricity covers such a tremendous field that the man who does not keep abreast with it does himself a great injustice. PRACTICAL ELECTRICS covers that field from every angle. It is written in plain every-day language that all can understand. It portrays the entire electrical development of the month faithfully in non-technical language. It caters to everyone interested in electricity, be he a layman, an experimenter, an electrician or an engineer—each will find in this magazine a department for himself and plenty more.

The September issue now on the news-stands contains 48 pages and over 100 different articles and over 100 illustrations, with an artistic cover in three colors. Professor T. O'Connor Sloane, Ph.D., is associate editor of the magazine.

INTERESTING ARTICLES IN SEPTEMBER  
"PRACTICAL ELECTRICS"  
Magnet-tricks The Electric Dog  
Thermo-Couple Pyrometer, By Clyde J. Fitch  
Electric Dampner Regulator, By George G. McVicker  
Toy Motors Small Transformers  
Repairman's Test Panel, By B. M. Blount  
Sending Pictures by Wire (concluded from August Issue)  
By Noel DeJseh  
Electrolytic Rectifiers  
Storage Battery for Demonstrations.  
Single Unit Million Volt Transformers, By D. F. Miner  
Artificial Lightning Experiments Gigantic Insulator

### PRIZES

This magazine offers a number of prizes, as follows:

Our \$50.00 Prize Contest for Junior Electricians and Electrical Experimenters includes as its elements simplicity, as great a degree of novelty as possible, and practicality.

An interesting \$100 prize contest is announced, for best new uses for old spark plugs.

Also a new prize contest giving four prizes amounting to \$37.50 for the best account of an odd electrical experience.

\$3.00 for the best article on Elec-Tricks, the new department.

\$3.00 for the best "short-circuit," the semi-humorous department.

In addition to this, the magazine pays high prices for all electrical experiments, electrical articles, etc.

See Current Issue for Full Details.

This issue also contains articles by some of the greatest electrical writers, workers and students. The magazine will prove a revelation to any one interested in electricity.

Every issue besides its many other features contains the following departments:

- "New Things Electric"
- "Experimental Electrics"
- "Electrical Digest"
- "Junior Electrician"
- "Elec-Tricks"
- "Motor Electrics"
- "Short Circuits"

"How and Why" (Questions and Answers.)

Make all checks payable to: "Practical Electrics Co."

R. N. 9-23

### SPECIAL OFFER

Gentlemen:

Although your regular price is \$2.00 per year, you will accept my subscription at \$1.75 per year (Canada and foreign \$2.25). I enclose the money herewith and I have written my name and address in margin below.

**PRACTICAL ELECTRICS CO., 53 Park Place, New York**

One of the instructing staff very wisely points out the fact that the real competitor of the radio retailer is not his brother radio dealer but the phonograph dealer, automobile dealer and other dealers in luxuries. Therefore, the radio salesman or store manager must be on a par with these experienced salesmen. The course eliminates the necessity of attending the "school of hard knocks" where most sales experience is gained. It is a short cut to experience. It brings the student in contact with big radio men. It covers the technical, organizing, and sales aspects of radio.

The laboratory of the school is made available to this class and they have the use of its excellent up-to-the-minute equipment. Furthermore, it is planned that several manufacturers will loan additional apparatus.

The radio retailer must be a salesman, business man, electrician, radio man, window display man, ad copy writer, show card writer and many other things. It is the object of this course to give the radio merchandiser a little information on everything he needs. A staff consisting of some of the most experienced radio men in New York will be in charge. The tuition rate will be very moderate and the full machinery of the Y. M. C. A. organization is available to any student who wishes to take advantage of the privileges.

All inquiries should be addressed to Mr. Arthur R. Nilson, Department of Education, East Side Branch Y. M. C. A., 153 East 86th Street, New York City.

#### ANOTHER FAIR DEALER

Editor, RADIO NEWS:

Please bring to the attention of the radio fans another fair dealer. I had a Sterling Mfg. Co., Cleveland, Ohio, storage battery charger that charges from A.C., 110-volt lines, and had good results for some time, but the brushes were mounted on fibre and in curling short circuited the charge. They had made changes in their new charger that corrected this, and also a voltage stabilizer. I wrote to them and they offered to bring it up to date, at no cost except Parcel Post. They have done this for me and returned the excess stamps I sent for Parcel Post.

Trusting the fans are interested in fair dealers, I remain,

RAYMOND HOOVER,  
Hillside, N. J.

#### THE PROFESSIONAL OPERATOR

Editor, RADIO NEWS:

It seems to be the popular belief that the professional radio operator's job is one of luxury and ease, all pleasure, no work and a large income. A large part of this is based on advertisements for correspondence courses, etc. No mention is ever made of the long dispatches and press reports the operator must make out, or the ear-breaking static of the southern regions which he must endure. He must buckle down and repair his own apparatus and in case of emergency, a heavy responsibility is placed on his shoulders.

There is a future for ambitious young men in radio, but they must work for it the same as in any other profession.

RICHARD PEDERSEN,  
Bridgeport, Conn.

#### PARDON US

Editor, RADIO NEWS:

Referring to the March, 1923, issue of RADIO NEWS, on page 1650, there appears an article entitled "Report of DX from Australia"; now the address of the successful station is at Timaru, New Zealand. This, however, is quite an all too common mistake, even in English magazines but I would like to correct you to avoid making similar errors in the future. New Zealand

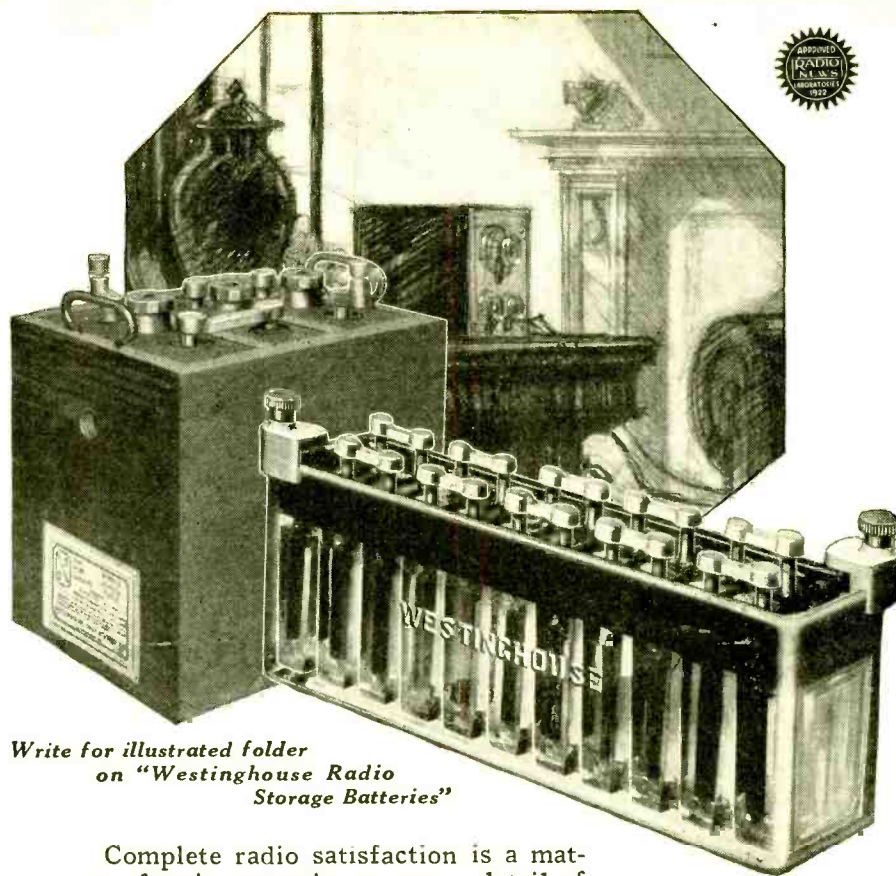

Write for illustrated folder  
on "Westinghouse Radio  
Storage Batteries"

Complete radio satisfaction is a matter of strict attention to every detail of your set. To many radio folk a battery may be "just a battery," but the fan who gets the utmost in results knows that *right* batteries are very, very important—just as important as right tubes, transformers, coils, aerials, etc. Westinghouse Batteries are the product of both battery and radio engineering. They are *even-powered* as well as full-powered. (You know how essential that is to fine tuning.)

You'll be well repaid for determining to have only Westinghouse Batteries. There should be a dealer near you who handles them. If not, get them at any Westinghouse Battery Service Station.

WESTINGHOUSE UNION BATTERY CO.  
Swissvale, Pa.

#### Westinghouse "B" Batteries

The 22-MG-2 (22 volts) is a marvel for long, steady, noiseless service. Glass case; visible interior; sealed-in tops. Larger types, too; also 2-volt single "C" cells.

#### Westinghouse "A" Batteries

are full-capacity, low-discharge, long-life batteries. Made in 4, 6 and 8 volt sizes, with 5, 9 and 13 plates per cell, to meet various filament requirements.



# WESTINGHOUSE

## Radio "A," "B" and "C"

### BATTERIES



THE WORLD'S GREATEST  
RADIO CRYSTAL

### Reflex Superiority! Results Guaranteed!

Are You Getting the Best From Your Reflex Set?

M.P.M. (Million Point Mineral) Crystal

—tested and guaranteed—has proven itself the superior crystal for Reflex Reception. M.P.M. will not corrode or burn out; does not lose its sensitiveness; and clear, musical, economical reproduction is assured. Unsolicited testimonials show marvelous long-distance records, both with and without amplification. Ask your dealer for M.P.M., or send us 50c for two unmounted, or 70c for two mounted; and, in addition to crystals, we will send you diagram of a reflex circuit that we guarantee will give absolute satisfaction.

M. P. M. SALES CO., Dept. N., 247 So. Central Ave., Los Angeles, Calif.

# A LOUD SPEAKER and REPRODUCER IN ONE BRISTOL AUDIOPHONE

**MORE THAN A LOUD SPEAKER** the AUDIOPHONE is a real reproducer of the original broadcasting. It is easy to listen to the Audiophone reproduction, because they are so perfect. The speech, songs and instrumental music are not blurred or disguised by mechanical distortion. You get all the fine shadings and every inflection. In fact, the very personality of the artist seems to be present as you listen.

**DEVELOPED** in the laboratories of an engineering firm known the world over for recording instruments of precision.

**COMPLETE** in every way and ready to connect to the receiving set.

**NO AUXILIARY BATTERIES** are required for magnetizing.

**ADAPTED** for use on all types of two or three stage power amplifiers.



TRADE MARK  
**AUDIOPHONE**  
REG. U. S. PAT. OFFICE

**MADE IN TWO MODELS:**  
BRISTOL AUDIOPHONE  
SR. Loud Speaker, Size of  
Horn 15-inches  
Diameter, Price ..... **\$32.50**

BRISTOL AUDIOPHONE  
JR. Loud Speaker, Size of  
Horn 11-inches  
Diameter, Price ..... **\$22.50**

THE BRISTOL SINGLE STAGE POWER AMPLIFIER for use with the usual two-stage amplifier can be furnished, which will greatly increase the range of the Audiophone where desirable. Price .... **\$25.00**

Write for Bulletin 3006-S.

**THE BRISTOL COMPANY,**  
WATERBURY, CONN.

Boston New York Philadelphia Pittsburgh Detroit  
Chicago St. Louis San Francisco



is more than 1,000 miles southeast of Australia.

The cause of quite a lot of confusion is, in my opinion, the term "Australasia," which is often taken by the uninitiated to be Australia, but, however, means Australia, New Zealand, and several other smaller surrounding islands.

Referring to the article once more: Timaru is about 110 miles south of Christchurch, so is really further away from the transmitting stations than we, but has better natural facilities for receiving, but now several American amateurs have been logged here so this would tend to verify Mr. Slade's statements. Also I might add that a broadcasting station at Los Angeles has been heard by an amateur, whose name is Mr. R. J. Orbell, one of the leading amateurs here. Radio frequency amplification was of course used for this.

V. LARSON, Hon. Secretary,  
Radio Society of Christchurch, N. Z.

## NEW ZEALAND PROGRESSES

Editor RADIO NEWS:

Being a subscriber to your magazine for the past twelve months, I would like to compliment you on its all-around efficiency. Both to the layman and the advanced worker, this magazine is certainly a 100 per cent investment, and more, it easily outstrips any other magazine of the same caliber on the market. The "I-Want-To-Know" pages are of incalculable value to all. Often one needs some little point cleared up, and in going over the "I-Want-To-Know" pages, one invariably finds the solution—at least, I have always found it so.

New Zealand is gradually going forward in the radio world, slowly, but the fact that it is going ahead is there. At present the de Forest people are ministering to our broadcasting wants, and their service is good. The Federal people also transmit musical items three nights a week. Judging by the interest among amateurs, a central broadcasting station does not seem to be very far away. RADIO NEWS seems to be easily first here in the magazine line, and so it should. My advice to all the "hams" is "When you're on a good thing, stick to it." RADIO NEWS does not need any boosting, it speaks for itself.

L. WATSON,  
Wellington, New Zealand.

## REGARDING WWJ

Editor, RADIO NEWS:

Referring to an article by Mr. J. F. Slocomb in the April issue of the RADIO NEWS, wherein he suggests that broadcast announcers should make known the call letters of their stations and their locations after each number.

I agree with him in that respect, but disagree in selecting WWJ station as an example for his accusations of carelessness, for, no doubt, had Mr. Slocomb heard the announcement preceding the four musical numbers, which he claims were played without a break, he would have heard the announcer say something like this: "The next number by the Detroit News Orchestra will be—, this number being played in four movements."

Here's hoping that Mr. Slocomb may listen in to many of the fine programs broadcast from station WWJ and hear the announcement before each number, which they give.

GEO. G. DESCAMPS,  
Asst. Consulting Engr.,  
Crescent Radio Assn.

## SOME RECORD

Editor, RADIO NEWS:

Reading in my RADIO NEWS the Low Power record made by 2CM in Australia, I have come to the conclusion that just as good DX may be done here. I have done

# LEARN THE CODE AT HOME

"Just Listen—The Omnigraph will do the teaching"

with the

## OMNIGRAPH

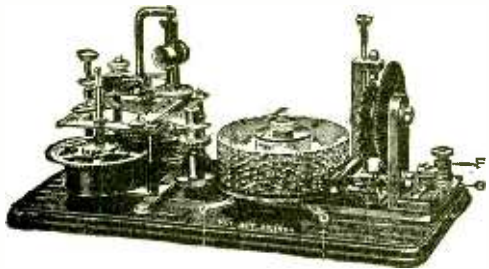

THE OMNIGRAPH Automatic Transmitter will teach you both the Wireless and Morse Codes—right in your own home—quickly, easily and inexpensively. Connected with Buzzer, Buzzer and Phone or to Sounder, it will send you unlimited messages, at any speed, from 5 to 50 words a minute.

THE OMNIGRAPH is not an experiment. For more than 15 years, it has been sold all over the world with a money back guarantee. The OMNIGRAPH is used by several Depts. of the U. S. Govt.

—in fact, the Dept. of Commerce uses the OMNIGRAPH to test all applicants applying for a Radio license. The OMNIGRAPH has been successfully adopted by the leading Universities, Colleges and Radio Schools.

Send for FREE Catalog describing three models, \$14 to \$30. DO IT TODAY.

**The Omnigraph Mfg. Co., 20 Hudson St., New York City**

— If you own a Radio Phone set and don't know the code—you are missing most of the fun

# MIRACO GETS 'EM 1500 MILES AWAY!

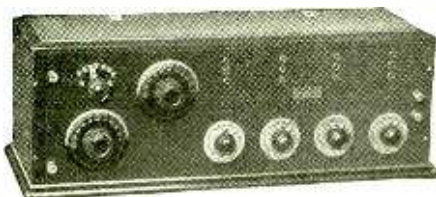

Users of MIRACO Radio Frequency Broadcast Receivers in either model shown report wonderful results. St. Louis hears Schenectady—Davenport hears Newark—Cincinnati hears San Francisco.

Reception is clear and distinct, tuning is very sharp and there is practically no interference.

MIRACO sets may be used with either 1½ Volt Dry Cell or 6 Volt Storage Battery.

Model M-W, 4 tube set—price \$54.50

Model K, 2 tube set—price \$29.50.

Order your MIRACO set today, or send for NEW Bulletin.

DEALERS — AGENTS — DISTRIBUTORS  
Write for our proposition TODAY.

**The Midwest Radio Company,**

804 Main Street

: : :

Cincinnati, Ohio

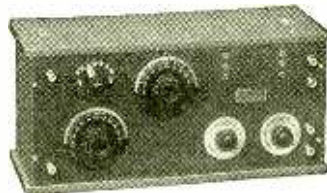

some myself. But the best I have ever heard of was 7AL's. On March 3rd and 4th, in the early morning, 7AL was heard here, CQing. The signals were clear and did not fade. Wrote him and had report confirmed. But the surprising part is that he was using a 1½ volt Peanut tube, with 45 volts on the plate, as he was trying to work around town. The set used was a one-tube regenerative, with a key in the ground lead. The outfit used at this end was a single-tube outfit, using the Mundt single-circuit hook-up. Another good record was made here in April. This station (6CKC) was heard nearly every night in the month by 6CEU in Hilo, Hawaii, a distance of 2,200 miles, when I was using one five-watt tube, 40 milliamperes on the plate, and the highest radiation used was from .4 to .5 of an ampere. 6CEU has since been worked on 10 watts A.C. C.W., with a radiation of 1.2 amperes. I believe the first two of these records could not be beaten in Australia.

JACK WARD, Radio 6CKC.  
Berkeley, Calif.



# CONTINENTAL

"New York's Leading Radio House"

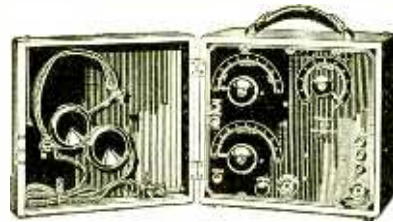

## Radiola II

*Light, Compact, Portable — Just the Thing for Summer Outings and Home Use*

Dealers! Winter customers are now summer vacationists. Winter radio sets must be supplanted by portable summer sets.

Radiola II, combining the portable feature with efficiency, provides a medium of enjoyment demanded by every summer vacationist.

Supply this demand by selling your customers a Radiola II.

*Distributors for the Radio Corporation of America.*

2046-O

CONTINENTAL RADIO and ELECTRIC CORPORATION  
SIX and FIFTEEN WARREN STREET, NEW YORK, U. S.

### With the Sea-Going Ops

(Continued from page 288)

making their own forecasts and weather maps daily, according to Chief Forecaster Edward H. Bowie, of the U. S. Weather Bureau. This is due primarily to efficient and immediate radio service.

Since his return from a long trip on the Atlantic Ocean in the French Ship "Jacques Cartier," Mr. Bowie is very enthusiastic over the prospects of forecasting at sea, and urges its practice on American vessels. With the vast amount of meteorological information broadcast today from practically all large radio stations, and many ships, it is possible, he says, for the Masters to make their own forecasts and even make a daily

## A COMPLETE RADIO EDUCATION

5

COMPLETE  
ACCURATE  
UP-TO-DATE  
INTERESTING  
VOLUMES

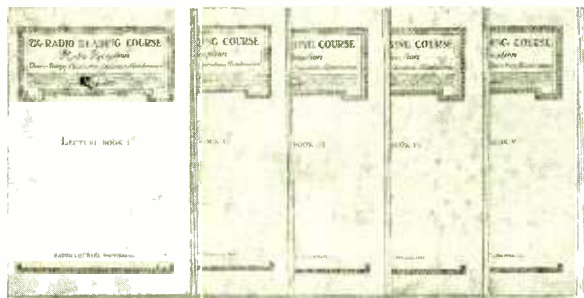

\$197

TOTAL COST  
TO YOU  
OF THIS  
WHOLE RADIO  
LIBRARY

### Do you know—do you enjoy the whole science of Radio?

If you know all the fundamentals of radio you get more pleasure and profit from it. New circuits, interesting experiments, inexpensive methods, perfect results—these things come naturally if you but know the real underlying principles. As an instance—you will learn how to use lighting system instead of storage batteries.

All this wealth of radio knowledge is given to you with marvelous simplicity in the five books of The Radio Reading Course. When you have acquired the practical radio theory contained in this wonderful set of books (and you will quickly and easily) you will know just what to do under any and all circumstances. You will be really acquiring the expert knowledge of a foremost radio engineer, inventor and one of the "fathers" of radio telephony.

#### Every Radio fan should own this famous set of Radio Books

Whether you enjoy radio as a hobby or are considering taking it up as a profession, you should own this famous set of Radio Books. To know is to enjoy—and you get this knowledge so inexpensively that you can't afford not to have it. The cost is practically nothing and you will save it many times over in your experiments. Take advantage of this remarkable offer explained at the right.

The Conrad Co., Inc.  
233 Fulton St.,  
New York, N. Y.

Gentlemen:

Send me at once the five complete books of The Radio Reading Course for which I agree to pay the postman only \$1.97 plus postage. Forward at once to

Tear out  
and mail this order

Name.....

Address.....

City and State.....

#### SEND NO MONEY

If you use the above order form at once you need send no money whatever to order this wonderful set of books. Think what their ownership will mean to you—all the important technical information—theory, design, construction, operation, maintenance—that it would take you years to learn in radio research laboratories, will be yours.

**Not necessary to send any money**  
*Pay the Postman*

Just send your name and address on the Reservation and Order form above and the complete five books will be delivered to your door. Upon receipt just pay the postman \$1.97 plus postage and the books are yours with the privilege of returning them in five days if you are not completely satisfied. Write today. Now!

**THE CONRAD CO., Inc., Agents**  
233 Fulton St., New York City

## A COMPLETE RADIO EDUCATION



**LOUD SPEAKERS AND REPRODUCING HORNS that have stood the test**



**T**RUTONE SENIOR—the loud speaker for all long-distance work—operates perfectly on two stages of amplification. The base contains built-in reproducer with heavy mica diaphragm. Beautiful crystalline enamel-finished non-metallic horn, 14 inches in diameter standing 32 inches high. Price \$25.00 complete with 6 ft. of cord.

Type B, pictured here, is a reproducing horn constructed of the same high quality material as the Senior and adapted for use with single phone receivers of any make. Type A is the same as Type B except that it is adapted for any make of two-phone receivers. Bell is 12 in. Horns stand 22 and 24 in. high, respectively. Either model complete, \$8.00. Horn only, \$6.00. Base only, \$2.00.

SENIOR  
\$25.00

**SADLER MANUFACTURING CO.**  
86 FOURTH STREET, SAN FRANCISCO, CALIFORNIA

TYPE B  
\$8.00

**“CLEARSTONE” “IF YOU WANT THE BEST”**

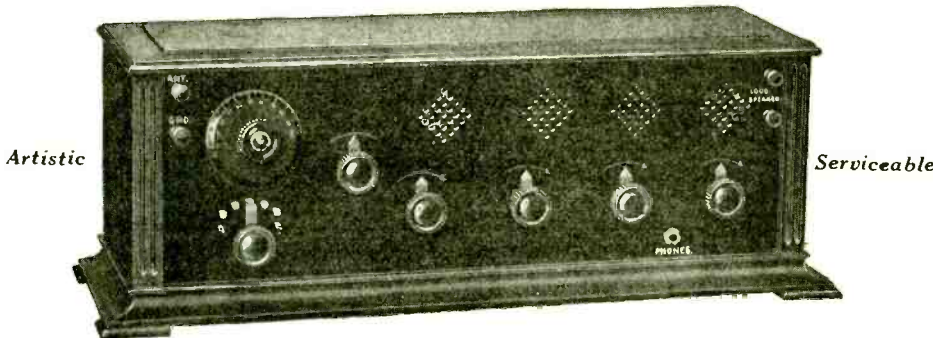

Artistic

Serviceable

**\$60.00**

MODEL RFAA-60

**\$60.00**

(Without Accessories)

For use with dry cell or standard 6-volt tubes.

(Without Accessories)

A four tube unit comprising one stage R.F. Amplification, Detector and two stages A.F. Amplification; the whole being enclosed in a beautiful solid mahogany cabinet. The wavelength range is 270 to 600 meters.

Many of our patrons are consistently receiving programs broadcast over ranges in excess of 1,500 miles without difficulty. It will pay you to investigate.

Literature free on request.

**JOBBER! DEALERS!**

The “big business” season is close at hand! Anticipate your requirements and place your fall orders NOW to assure good delivery.

**THE CLEARSTONE RADIO COMPANY**

McMILLAN and ESSEX PLACE

CINCINNATI, OHIO

| PHONE SPECIALS                  |         |
|---------------------------------|---------|
| SIMPLEX SPECIAL 3000 OHM \$3.65 |         |
| 2000-Ohm Frost                  | \$4.08  |
| 3000-Ohm Frost                  | \$4.92  |
| 2000-Ohm Murdoch                | \$4.12  |
| 3000-Ohm Murdoch                | \$4.97  |
| Western Electric                | \$9.62  |
| 2200-Ohm Federal                | \$5.95  |
| 2000-Ohm Kellogg                | \$5.92  |
| 2400-Ohm Kellogg                | \$7.89  |
| 2000-Ohm Manhattan              | \$4.22  |
| 3000-Ohm Manhattan              | \$4.92  |
| 3000-Ohm True Tone              | \$3.92  |
| 3000-Ohm Dictograph             | \$6.43  |
| Braudes Superior                | \$3.87  |
| Baldwin Type “C”                | \$9.57  |
| American Elect. Special         | \$3.94  |
| Braudes Navy Type               | \$11.21 |

Send Stamp For Complete Price List.  
SIMPLEX RADIO CO., 1806 Lafayette Ave., St. Louis, Mo.

**RHAMSTONE★**

Victrolphone Loud Speakers, Amplifying Cabinets R. F. and A. F. Transformers, Rheostats, Potentiometers, etc., at attractive prices. Catalog on request.

**J. THOS. RHAMSTONE★**  
2152 East Larned St. Detroit, Mich.  
\*Maker of Radio Products

plot of weather conditions, just as is done in the Weather Bureau in Washington. The Naval Radio station at Arlington sends out daily a general report from North America and in return receives a similar report from Paris on European conditions.

Since most storms journey eastward, a “skipper” in the Atlantic knows generally what is coming and by keeping in touch with vessels west of him he can do his own forecasting. In turn, he keeps other ships posted as to conditions in his location, and by co-operation many floating weather bureaus will eventually benefit each other and the countries with which they are in touch.

Several new radio stations to transmit weather information from the north of this country are now planned, Mr. Bowie stated; one at Cape Farewell in Greenland, three in MacKenzie Valley, Canada, and one on Baffin Island.

“Radio has done wonderful things for meteorology,” Mr. Bowie said. “In the old days we issued statements, ran up storm warnings on the coasts and had to let that suffice, whereas today we broadcast everything and ships at sea are as well informed as shore stations.”

**PHYSICIAN SUMMONED BY RADIO**

The steamship *West Cahous*, lying at anchor in Baltimore harbor, about nine miles from the city, needed medical help at about 3 a. m. recently, and needed it quickly, says the U. S. Public Health Service. A member of the crew had fallen into the hold and had hurt himself seriously. So the captain of the ship sent a wireless broadcast asking help.

The call was picked up, not in Baltimore, nine miles away, but at Cape May, N. J., about 100 miles due east of Baltimore. As Cape May was separated from the *West Cahous* by parts of New Jersey and Delaware and by the eastern shore of Maryland, not to mention Delaware and Chesapeake Bays, no direct help from it was possible.

But the operator was on the job. Promptly he consulted the long distance list in the Baltimore telephone directory and called up the residence of the Public Health Service surgeon in charge of the Marine Hospital in Baltimore—100 miles to the west. The surgeon, roused from sleep to receive the message, asked him to radio certain emergency treatment to the *West Cahous* and to direct the captain to send a boat to a certain pier in Baltimore, where he would find a surgeon waiting to go out to the ship with him. And so, in the middle of the night, in less than an hour, a wireless-controlled sea-going ambulance carrying a Public Health Service officer reached the side of the injured sailor and brought him later to the hospital.

**SEAMEN'S RIGHTS TO MEDICAL RADIO SERVICE**

The probability that some masters of sea-going vessels may not, as yet, have been fully informed in regard to the right of members of their crews to medical service by radio while at sea and to treatment in U. S. Public Health Service hospitals on reaching port, has caused Surgeon General H. S. Cumming to direct the preparation and sending of posters giving full information to all vessels of the American Merchant Marine.

Curiously enough, this medical service is really a sort of subsidy to merchant ships and sailors. A century and a quarter ago, when Congress established the Public Health Service, under the title of the Marine Hospital Service, it directed it to render medical aid to every American seaman who applied for it, and for this purpose each seaman should pay 20 cents a month. This was in 1798; in 1870 the tax was doubled; but in 1888 it was abolished; and since then all such aid has been rendered free. Even the expense

of calling the Service by radio from away out at sea is borne by the radio companies without expense to ship or sailor.

The forthcoming poster announcement reads as follows:

"The U. S. Public Health Service provides hospital care and outpatient treatment for sick and disabled seamen. Hospitals with modern equipment, skilled physicians, specialists, dentists, and trained nurses are open to all persons employed on documented American vessels, and to the Coast Guard, Lighthouse Keepers, and certain others who help to keep the flag on the seas. An ambulance will go to the dock at any time upon telephonic call from a ship's officer.

"As you are proud of a good ship, take pride also in keeping your own body healthy. Most injuries are due to carelessness. Most diseases can be prevented. Prompt care of small injuries may save a limb. Early treatment for disease may save a life or prevent months of illness. Learn to keep well. Pamphlets on tuberculosis, venereal disease, and other common diseases are sent on request by the Surgeon-General, U. S. Public Health Service, Washington, D. C. A book, "The Ship's Medicine Chest and First Aid at Sea" will be sent on request to the master of the vessel.

"Any Marine Hospital will prescribe emergency treatment through radio shore stations."

**WYOMING OPERATES IN DUPLEX**

Highly gratifying results have been secured with a new model high-power tube transmitter installed on the battleship *Wyoming*, and used in regular traffic. "In fact," states a Naval report, "some results were unexpected, such as ability to receive on the same vessel during full power operation of this tube rating about 5 K.W." Numerous broadcasting stations transmitting on 400 meters were tuned-in in the auxiliary radio room, while the big transmitter, installed in the main radio room, was supplying 36 amperes to the main antenna on a wave length of 507 meters. The receiving set in the auxiliary room was equipped with an amplifier consisting of three stages of radio-frequency and two stages of audio-frequency. "This condition allows duplex communication, which has actually been put in practice on the *Wyoming* and will be further developed on the *Colorado* and *West Virginia*," the report states.

**RADIO ROOMS RELOCATED FOR DUPLEX OPERATION**

The arrangement of the radio rooms on these two battleships will differ from present Naval practice. Receiving will be done in the main receiving room forward, and transmission will be carried on aft from the main transmitting room.

In Naval Aviation Squadrons new tube sets are also replacing spark sets. Five new aerial spotting sets have passed satisfactory tests and are en route to the Air Squadrons of the Battle Fleet, where they will replace SE 1345 sets now in use. Spark sets will be used only at Pensacola for training Naval radio personnel.

**DIRECTION FINDING STATION TO BE INSTALLED ON VANCOUVER ISLAND**

The Vancouver meteorological office has just been advised by the Ottawa government that equipment has been ordered for the establishment of a wireless direction-finding station at Pachena Point, on the west coast of Vancouver Island, which it is claimed, will operate conjointly with the American station of like character at Tatoosh, Washington, enabling vessels about to enter the Straits of Juan de Fuca to get cross-bearings for calculating position, thereby rendering invaluable assistance to navigation. Had such a station existed the S. S. *Tuscon Prince* would probably not have met with



Use Ray-O-Vac "B" Batteries for sustained voltage, longer service and elimination of noise.

*Everyone can have Radio*

Everybody ought to have a radio set these days. With WD-11 or WD-12 Dry Battery Tubes and Ray-O-Vac "A" Dry Cells, you can have a first class set at reasonable cost.

If you already have a set, you can bring it up to date easy enough. With this 2-pound battery there is no recharging, no mussy testing, no complicated knowledge needed.

Get Ray-O-Vac "A's" for a new thrill out of radio. 200 hours of real service when properly connected. Units include 1, 2, 4, and 6-cell sizes. Whether you have a set or merely plan on it, you should send for the free booklet, "How to Get the Most Out of Radio". It tells you the things you want to know about radio.

Ask your dealer for this battery.

**FRENCH BATTERY & CARBON COMPANY**

Madison Wisconsin  
Atlanta Chicago New York Minneapolis Kansas City  
Dallas Denver

**RAY-O-VAC**  
*The Battery that Completes Radio*

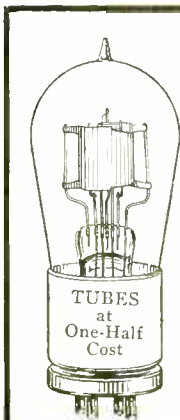

**IT HAS HAPPENED TO ALL OF YOU IN A FRACTION OF A SECOND!**

WHEN the filament burns out, at least \$5.00 goes with it to put the set in operation again.

WHY not save nearly one-half the cost of a new tube by sending us your burned out or broken tube to be repaired?

WE REPAIR EVERY TYPE of tungsten wire filament receiving tube. All our tubes are TESTED and GUARANTEED to function as well as when new.

*All tubes returned P.P., C.O.D.*

**HARVARD RADIO LABORATORIES**

BOSTON

P. O. BOX 1781

MASS.

MASTER

# Radio Products

overcome the uncertainties of Broadcast reception and insure a reality that secures lasting interest.

Clear sounding, efficient instruments, made from parts manufactured and assembled in our own plant, will add strength and prestige to any dealer's business, just as they have enhanced the reputation of ourselves.

Some of the most successful dealers in America are featuring "MASTER" Radio Products as something "different" and of a character befitting the institution behind them.

*Bulletins RN-104 and RN-105 describe and illustrate the complete "MASTER" line*

RADIO DIVISION  
UNION CONSTRUCTION COMPANY

Manufacturers "MASTER" Radio Products

OAKLAND, CALIFORNIA

502



## Nature in her Grandeur

has placed for our admiration and use many things. We admire the rugged beauty of the mountains. We admire the beauty of, and utilize the power of waterfalls.

Usually, the forces of Nature which we most admire and utilize are those which appeal to our higher senses. Many of the most useful of Nature's forces require "man-made" devices to make them manifest. This is especially true of that grand force of Nature, RADIO. In a SERVICE Radio receiving set we may combine beauty and utility.

The story of SERVICE will be told serially in this publication—or, if you prefer the entire story, write us for booklet.

SERVICE sets are the simplest to operate and made for the entire family. "Keep the children at home by giving them service." This is a new company but the engineers and management have been connected with some of the largest firms and only by a combination of these men can you get the most up-to-date SERVICE.

Dealers write for prices, terms and territory.  
Dealers' names will be published in our advertising.

*"This is a TELEFORCE Product."*

**SERVICE RADIO COMPANY**

4727 Montgomery Road

NORWOOD, OHIO

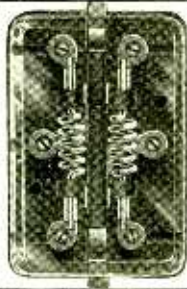

## Make Your Aerial Safe!

It has all the dangerous possibilities of a lightning conductor—and it leads right into your house! Protect yourself from injury, your house from fire, and your instrument from damage by the use of a

**H - C LIGHTNING ARRESTER**

WITH GLASS COVER

**90 CENTS**  
Postpaid

**HOLTZER-CABOT ELECTRIC CO.**  
6161 South State Street, Chicago, Ill.

Insure your copy reaching you each month. Subscribe to Radio News—\$2.50 a year. Experimenter Publishing Co., 53 Park Place, N. Y. C.

the disaster which occurred February 14, last.

It is said the apparatus should be ready for installation within two months; immediately upon its receipt, tests will be made to determine its final location.

## I Want To Know

(Continued from page 290)

### WD-11 WITH SUPER

(753) Mr. Anson D. Marston, Ames, Ia., writes:

Q. 1. Can a WD-11 tube be used with the "Super" shown on page 1097 of the December RADIO NEWS?

A. 1. A WD-11 tube will give fair results when used in this circuit. On account of the lower plate voltage necessary, the volume of sound will not be as great as when a six-volt tube is used.

Q. 2. Can a pair of spiderweb coils be used in place of the variocoupler?

A. 2. Two spiderweb coils can be used in place of the variocoupler, if desired. A coil of at least 100 turns would be necessary for the tickler.

Q. 3. What are the voltages of the "B" and "C" batteries?

A. 3. Not more than 90 volts should be used for the "B" battery. The "C" battery will be from 3 to 9 volts.

### ONE, TWO AND THREE CIRCUIT

(754) Mr. H. L. Jones, Atlanta, Ga., wants to know:

Q. 1. Will you please publish the difference between a one-, two- and three-circuit tuner?

A. 1. There seems to be a good deal of misunderstanding on this subject. A single-circuit receiver consists of a circuit in which there is one coil only for tuning, this serving as both the primary and secondary. A receiver using a single coil would be called a single-circuit tuner. A two-circuit receiver consists of a primary and secondary coil, both of which can be tuned by taps or condensers. Both the single and two-circuit tuners can be made regenerative by inserting a coil in the plate circuit of the detector, and putting it in variable inductive relation to either the primary or secondary of the tuner. A three-circuit receiver is a two-circuit one with the addition of a variable coil or variometer in the plate circuit of the detector tube. This gives three circuits to be tuned—primary, secondary or grid circuit, and plate. A three-coil honeycomb receiver is not a three-circuit receiver, but is a regenerative two-circuit tuner. Following this same line, a so-called single-circuit tuner, using a variometer in the plate circuit, for regeneration, is really a two-circuit receiver, even though commonly called a single circuit.

### CHANGE OF CIRCUIT

(755) Mr. Ernest C. Roberts, Chilliwach, British Columbia, Canada, wants to know:

Q. 1. At present I am using a single-circuit regenerative receiver, with which I have received over 1,000 miles. Would I get better results if I changed to a three-circuit receiver?

A. 1. If you do not experience any bad interference with your present set, we would not advise any change. A three-circuit tuner is more selective, but the receiving range will be about the same.

Q. 2. Which hook-up would give louder and more satisfactory results with one stage of audio frequency amplification?

A. 2. Audio frequency amplification has no bearing on the tuning qualities of a receiver. It simply amplifies the results obtained from the detector.

Q. 3. Do you think that just as good results can be obtained by using 1½-volt peanut tubes instead of the five and six-volt tubes?

A. 3. Tubes using 1½ volts on the filament are good audio frequency amplifiers, but better results will be obtained with six-volt tubes.

### CORRECTION

The circuit diagram of the portable receiver described by W. B. Hodgson, on page 44 of the July issue, shows the grid variometer connected directly to the grid of the vacuum tube. Instead, this lead of the variometer should connect between the grid condenser and leak, and the two aerial condensers.

The dimension given for the diameter of the tube employed as the stator is the inside diameter, not the outside. In order to avoid any mishap, this outside tube be allowed an inside diameter ¼" greater than specified, since a slight discrepancy in the measurements of the shaft holes will put either or both tubes off center.



## General Harbord Explains the Patent Situation

(Continued from page 252)

very important improvement inventions were the subject of controversy in the United States Patent Office between the General Electric Company and the American Telephone & Telegraph Company. No one concern could manufacture the modern vacuum valve without infringing patent rights held by others. The most usual connection of the valve for reception purposes was covered by the Armstrong patent, held at that time by Armstrong himself.

When, in response to the demand of the Director of Communications of the United States Navy, the formation of an American Radio Corporation was undertaken, it was realized that one of the most vitally important things that had to be done was to clear the patent situation so that it would be possible to embody in one vacuum tube, or in one piece of apparatus, a sufficient number of patented inventions to make that tube or apparatus satisfactory for use in a trans-oceanic reception station.

To bring this about, it was necessary for the Radio Corporation to acquire rights from the American Marconi Company, from the General Electric Company, from the American Telephone & Telegraph Company and from the Western Electric Company. But this was not enough. The important patents of Fessenden were owned by the International Company, in which the Westinghouse Electric & Manufacturing Company was interested, and the Westinghouse Company by that time owned, subject to certain licenses, the very important Armstrong "regenerative" patents.

By years of hard work, and by great sacrifice, these difficulties and other patent difficulties were overcome, and the Radio Corporation found itself free to go ahead, so far as the patents of these various groups were concerned.

### POLICY OF THE RADIO CORPORATION

The Radio Corporation had the absolute right to enforce every patent right which it owned against every user. It did not, however, adopt this policy, but instead decided on a policy which is entirely in keeping with the high ideals which have characterized its policy since its inception. The Radio Corporation decided that if an amateur wanted to build his own set, for his own personal use, he could do so, and that it would not, until further notice, treat such procedure as an infringement of its patent rights.

But there is absolutely no reason why the Radio Corporation, which ought to earn dividends on the shares which it issued to acquire this property represented by important patents, and which shares are now owned by thousands of stockholders, should allow this property in patents to be recklessly trespassed upon by hundreds of rival manufacturing companies, most of which make no contribution whatever to the art, have made no investment in property patent rights, and merely attempt to "reap where others have sown."

The Radio Corporation is, therefore, proceeding to enforce some of its rights by the normal, orderly process of suit in the Federal Courts. It is not attempting to create a monopoly; it is attempting to enforce the lawful rights, limited in scope and in time, which it has been necessary for it to acquire in order that the radio art might go forward.

In some cases the Radio Corporation has purchased patents outright; in other cases it has taken exclusive licenses; in some cases its licenses were not exclusive. In the particular case of the Armstrong regenerative patents (not the super-regenerative) the



No. 139 Plug 60c

No. 131 Jack 90c

# FROST-RADIO

## PLUGS and JACKS

**YOU** know how important quality is in radio plugs and jacks. Unless made with the utmost care and precision they will cause endless trouble on your set. That's why you should insist upon using only FROST-RADIO Plugs and Jacks.

**Highest in Quality**

Each part in a Frost Plug or Jack is made with watch-like exactness. The best of materials go into them. Careful inspection insures a perfect product.

Correct design—finest insulation—best construction—have made FROST-RADIO Plugs and Jacks the most popular in the world.

**Your Dealer Handles Them**

Go to your dealer today and select from the FROST line the plugs and jacks you will need for your new set. Ask him to show you the new Frost Jack for the Neutrodyne circuit.

# HERBERT H. FROST, Inc.

154 WEST LAKE STREET, CHICAGO, ILLINOIS.

30 Church Street, New York

Makers of the famous Frost-Fones



### Design and Construction of Audio Amplifying Transformers

Radio and Audio Frequency Type



This book will be of great interest to all radio amateurs. The transformers have never before been described in print. The possessor of vacuum tubes cannot afford to do without this book. It will enable him to build the necessary amplifying transformers very readily. The book is printed on good paper and has an attractive cover in two colors. Paper bound. Size, 5 inches by 7 inches. Contains many illustrations, diagrams and working data.

Price 25 Cents Postpaid

Dealers Write for Wholesale Discounts

Experimenter Publishing Co.

53 Park Place New York, N. Y.

# RUSONITE



**CRYSTAL RECTIFIER**  
(Patent Pending)

THE PERFECT SYNTHETIC CRYSTAL DETECTOR SENSITIVE OVER ENTIRE SURFACE

No Hunting for "Spots," Loud and Clear. Endorsed by Thousands of Satisfied Users.

|  |               |               |
|--|---------------|---------------|
| Sensitiveness                              | Price Mounted | <b>50c</b>    |
| 14 K. Gold Supersensitive                  |               |               |
| <b>RUSONITE CATWHISKER</b>                 | Price         | <b>25c</b>    |
| Permanent. Will not Oxidize.               |               |               |
| <b>RUSONITE REFLEX CRYSTAL</b>             |               |               |
| Manufactured Expressly for Reflex Circuits |               |               |
| Will Stand Up Under Heavy Plate Voltage    | Price Mounted | <b>\$1.00</b> |
| Guaranteed                                 |               |               |

Order from your dealer or direct from  
**RUSONITE PRODUCTS CORP.**

15 Park Row New York, N. Y.

# Your Best Summer Customers



**T**HE OWNERS of motor boats and yachts — they all want radios on board. And they want them NOW during the summer months — when the radio business is slack. That's why they are your best bet as customers.

In response to this big demand MoToR BoatinG, the national magazine for motor boatmen, is running a special series of articles on radio for motor boats — in addition to its other regular features.

## Don't Neglect the Motor Boatmen!

They will respond more heartily to your radio advertising than any other summer group. Because they are eager to buy now. And the surest way to reach them all is through MoToR BoatinG.

Tell them your story in their OWN favorite magazine—



119 West 40th Street  
New York City, N. Y.



"Built first to Last"  
RADIO PRODUCTS  
Coto-Coil Co.  
Providence, R. I.

Radio Corporation's exclusive license in this field is subject to a number of non-exclusive licenses which were granted some years ago by Major Armstrong, not by the Radio Corporation. The Radio Corporation, when it purchased the rights which it holds under these patents, naturally took them subject to whatever prior licenses had been granted. This means that there is a number of concerns in this country which have certain licenses under the Armstrong regenerative patents. But it will be obvious, under the circumstances, that these licensees have no rights under the other patents of the Radio Corporation.

### THE VACUUM TUBE PATENTS

The soul of modern radio is the vacuum tube. When the Radio Corporation started to clear the patent situation, the most difficult and the most important patent problem before it was to acquire the necessary rights with respect to vacuum tubes, since without the vacuum tube it would be impossible to construct a receiving system for transoceanic telegraphy capable of giving the character of service which the Radio Corporation wished to give.

When this situation was cleared up, the Radio Corporation faced another question—this time, a question of policy; namely, whether or not, and to what extent, it could satisfy the urgent demand of the amateurs for vacuum tubes. If satisfying that demand incidentally involved selling for a few hundred dollars, tubes enough to double the value of millions of dollars' worth of transoceanic transmitting and receiving stations; if it meant that merely by purchasing tubes from a dealer any rival concern could secure for a few dollars the rights which had cost the Radio Corporation so much effort and sacrifice—surely the Radio Corporation would never have sold a tube! But the amateurs wanted tubes, and the Corporation was willing and anxious to let them have them; glad to see the art advance in this way and glad to get whatever profit there was in the tube business—but only if it could sell the tubes for legitimate uses only.

### TO PROTECT THEIR PATENT RIGHTS

Some of the patent claims cover the tube; others the combination of the tube with certain circuits or circuit elements. The Corporation is willing that the amateur should construct, in good faith and for his own amateur use, the circuits in question, and incorporate in such circuits the tubes which the Radio Corporation sells for that purpose.

But the Radio Corporation is not willing that the policies which it pursues for the benefit of the amateur should be made the basis of an attack of its fundamental rights. It is not willing, for example, that tubes sold by it for amateur use only should be used by rival communication companies, as is actually being done.

Further, it is not willing that rival manufacturers should construct and sell sets which, when once a tube is placed in them, will infringe the Radio Corporation's patents. It was not for such purposes as these that the Radio Corporation cleared the road.

This infringer has the advantage that he has no patent investment, no research to finance, no responsibility to the art. He can make a thing and sell it; if he makes a dollar profit the dollar is his—until the courts take it away from him, which can only happen after a long litigation. The thousand stockholders who have associated themselves together as the Radio Corporation, which is a great concern, have made all this development possible; and this concern, which has spent millions in clearing the road for American radio, has to earn something on what it spent in clearing the road. The enforcement of its patent rights by the Federal Courts will help it to earn that something. If its rights are not as broad as it believes them to be, the courts will say so. In its efforts to test its rights, to find out just

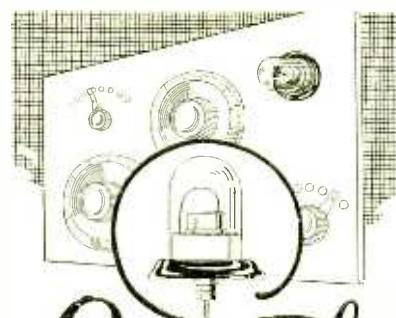

## Grewol Detector

Continually Satisfactory

The Grewol is adjusted on the most sensitive spot on the crystal and fixed—proof against vibration and jar. Protected from dust and moisture by glass cover, which can be removed to readjust catwhisker. Adds to efficiency of your set.

LIST  
\$2.00

Write for booklet.

RANDEL WIRELESS CO.

9 Central Ave., Newark, N. J.

Jobbers and Dealers—Write for Discounts.

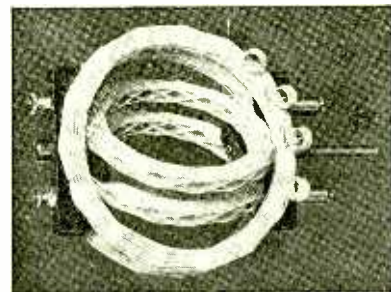

## R. M. C. Sickles Diamond Weave Variocoupler

Wound to eliminate capacity and dielectric losses. Low distributed capacity—high inductance. Requires very small space—screw holes covered by 2" dial. Adaptable to all circuits requiring variocoupler. Provided with seven taps, equally spaced, on primary. Sickles Variometer similar in construction. Extreme maximum and minimum values. Highest quality in material and workmanship.

Variocoupler ..... \$4.25  
Variometer ..... 4.25

Send for catalog showing Radio Frequency Transformer.

THE RADIO MANUFACTURING CO.

of Springfield, Massachusetts

Dept. A 97 Dwight St.

## CONNECTICUT RADIO

Panel and Portable type Variable Condensers, Audio-Frequency Transformers, Vacuum Tube Sockets, Rheostats, Head Phones, Jacks, Plugs and Switches. Send for Bulletin A-12

CONNECTICUT TELEPHONE & ELECTRIC COMPANY  
MERRIDEN CONNECTICUT  
Radio Division



### SUPER V. T. SOCKET

These Sockets have phosphor-bronze springs with inclosed bayonethook. The quality socket at a low price. White Porcelain ... 20c. ea. Brown Porcelain ... 25c. ea. Gummi Bakelite ... 30c. ea.

Discount to dealers.  
L. S. R. Elect. Mfg. Co.  
132 Pitman St., Prov., R. I.

what they really are, and to enforce them, the Radio Corporation should have the sympathy of everyone who really wishes the good of the radio art, for if such rights, acquired under such circumstances and at such cost, are not sustained and enforced, who again will feel justified in taking such risks and making such expenditures as were taken and made when the Radio Corporation was formed?

### Radio News Laboratories

(Continued from page 287)

ing crystals. The shells are of moulded material. The head-band is of metal and is not insulated.

Arrived in good packing.

AWARDED THE RADIO NEWS LABORATORIES CERTIFICATE OF MERIT NO. 187.

### SKINNER DETECTOR CRYSTALS

These detector crystals, which were submitted by W. E. Skinner, Minneapolis, Minn., were all tested and found to be very sensitive. There were 15 samples in all. Each was packed in cotton in a small wooden



box, with instruction sheet and diagrams. All of the crystals were galena, and furnished both mounted and unmounted. The mounted type are designed to fit the standard 1/2" detector cup.

AWARDED THE RADIO NEWS LABORATORIES CERTIFICATE OF MERIT NO. 180.

### PREMIER DUPLEX HEAD-SET

This head-set, which is manufactured by the Premier Accessory & Specialty Corporation, 29 Congress street, Newark, N. J., was found to possess all the desirable features for this type of instrument. It was found very sensitive to weak signals and



would readily reproduce radio broadcast concerts with the minimum of distortion. The phones are of the standard size and construction.

Arrived in excellent packing.

AWARDED THE RADIO NEWS LABORATORIES CERTIFICATE OF MERIT NO. 198.

# RADIOGEM

The Dollar Radio Receiving Set  
The Simplest Radio Outfit Made  
—Yet as Practical as the Most Expensive!

You need know absolutely nothing about wireless to operate and enjoy the RADIOGEM. It is so sturdy, so simply constructed that it is small wonder radio engineers who have tested it have pronounced the RADIOGEM a brilliant achievement. The RADIOGEM is a crystal radio receiving set for everyone at a price anyone can afford.

Why The RADIOGEM Can Be Sold For Only \$1

Here's the secret: The RADIOGEM Construction eliminates all unnecessary trimmings, cabinets and the like, which do not play any part in the operation of a set. You receive the RADIOGEM unassembled, together with a clearly written instruction book, which shows you how to quickly and easily construct the set, using only your hands and a scissor. The outfit comprises all the necessary wire, contact points, detector mineral, tube on which to wind the coil, etc., etc. The instruction book explains simply and completely the principles of radio and its graphic illustrations make the assembling of the RADIOGEM real fun. Remember the RADIOGEM is a proven, practical radio receiving set and will do anything the most expensive crystal set will do.

The RADIOGEM is the Prize Winner of the Age

Out of hundreds of radio models submitted recently in a great nation-wide contest, radio engineers, the judges, unanimously chose the RADIOGEM as the winner—the simplest radio-receiving set made! And the RADIOGEM costs you nothing to operate; no form of local electricity is required.

Sent Postage Prepaid on receipt of \$1 —stamps, money-order or check.

Order Your Radiogem To-day— or send for Free Descriptive Circular

## DEALERS

The RADIOGEM is the wonder item of the radio age. It is storming the country, for the RADIOGEM'S price is so low everyone is able to buy one. Write immediately for full particulars before that shop across the street beats you to it.



Hear the programs of the Broadcasting Stations on the RADIOGEM



\$1 without PHONE or AERIAL (Patent Pending)

### What They Say About RADIOGEM

I am enclosing herewith \$1.00 to pay for the Radiogem. I had it carefully wound by our wireless operator and find that it works beautifully—fully as good as any crystal set we know of.

Radiogem received, which we assembled and were very much astonished at results obtained and the clearness and volume of tone produced.

The greatest distances I heard on one of your sets is 1000 miles, having heard WGY at Schenectady, N. Y. I think your set is the best I have ever sold at any price.

On an aerial 160 feet long and 20 high one of my customers has heard WOC and WHB, KSD, WMC on one of your sets using a Peerless headset.

Herewith P.O.M.O. amt. \$1.00 for another "RADIOGEM." The one received is O.K. Placed about 15 ft. of picture cord under front porch and grounded to a gas meter, and heard the Sacramento Bee and Sacramento Broadcasting Union much better than with my large crystal set.

Your RADIOGEM RECEIVER is a wonder. I have received every station in Philadelphia with it much louder than with a high-priced crystal set.

Your two Radiogem sets received last night, and one was wired up for testing. WOC is about 40 miles away, and their signals could be heard with headphones on table. After they quit KYW at Chicago about 170 miles east was heard. Every word could be plainly heard here. WMC at Memphis, Tenn., could also be easily heard and understood.

We find that this set does a great deal more than you claim for it. We took WEAAR on our audition set last night; this being the Baltimore American Broadcasting station, and then cut in the Radiogem and got excellent results. After the Baltimore concert was over, we continued to use the audition set and about ten o'clock were listening to WEAAR—New York—and a little later we disconnected the audition set entirely and hooked up the Radiogem, very clearly hearing both piano music and announcement of name of station and its location.

You claim a radius of 20 miles over your "Radiogem" is sometimes a possibility. You should adhere to the truth. I constructed one for my mother, installed it with an aerial, and she listens not once in a while, but at her will, to Schenectady, Newark, New York, or Providence, R. I., and her home is Attleboro, Mass. I can't give your set too much praise.

(Names and Addresses on Request)

## WOC--TRESKO

Licensed Armstrong U. S. Patent No. 1113149

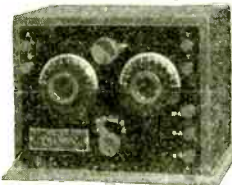

Two things that made Davenport famous. A complete 2000 mile Armstrong regenerative tuner for \$25.00. Use it with any make bulb W.D. 11 or 12, or dry battery operation as well as storage battery. Portable set to use at camp or in your machine. Complete with bulb, batteries and phones, etc., \$37.50. Circulars free. This set received the Chicago American Regional Prize of \$350.00.

### TRESKO

Tri City Radio Elec. Supply Co. Box 148 Davenport, Iowa

## VACUUM TUBE HOSPITAL

We Repair and Guarantee Them

Repairing the following tubes and many others

Vacubub Amplifiers and Detectors  
Moorehead Amplifiers and Detectors

DeForest Amplifiers and Detectors  
Cunningham C-289-C-300-C-301-C-301A-C-302

Radotron T-V-199-200-261-201A-202-WD-11-WD-12

Reasonable Prices

Mail orders solicited and promptly attended to.

Satisfaction Assured



GEORGE H. PORELL CO., Inc.

Telephone: 7931-R

SOMERVILLE (44) MASS.

Get a Handy Binder for your RADIO NEWS. Holds and preserves six issues, each of which can be inserted or removed at will. Price 65c. Experimenter Pub. Co., Inc., Book Dept., 53 Park Place, New York.

Warren Radio Loop, Cut Away to Show Construction.



**WARREN RADIO LOOP**

### An Aerial Adjustable to Station

Practically gives you an aerial for every station, because it can be directed broadcast at the station you want to hear. Yet a Warren Radio Loop is hardly larger than a small atlas, fits in anywhere and never makes any trouble. Patented exclusive features. All enclosed, compact, and extraordinarily sensitive.

Send for Bulletin T102, containing hook-ups.

**A Type For Every Set At The Best Dealers**

|  |         |
|--|---------|
| Type A-737 (300-700 meters) 6 inches square—non-directional .....                        | \$10.00 |
| Type A-7236 (175-1000 meters) 6 inches square—non-directional .....                      | 12.00   |
| Type B-2537 (300-700 meters) 18 inches square—directional .....                          | 20.00   |
| Type BL-2520 (200-18,000 meters) with honeycomb coil, 18 inches square—directional ..... | 25.00   |

**V-DE-CO RADIO MFG. CO.**  
ASBURY PARK, N. J.  
Dept. N

### RADIO APPLIANCE HEAD SET

The Radio Appliance Manufacturing Co., 6282 Beaubien street, Detroit, Mich., submitted a sample of their 3,000-ohm phones, which are shown in the illustration. This head-set is very light in weight and can be worn a long time with comfort. It is of the



standard size and construction. The shell and cap are of moulded insulating material. Excellent results were obtained as regards sensitivity, over a wide band of frequencies ranging from 200 to 4,700 cycles per second. Arrived in excellent packing.

**AWARDED THE RADIO NEWS LABORATORIES CERTIFICATE OF MERIT NO. 196.**

### Broadcasting and the Swedish Telegraph Department

(Continued from page 255)

place, thus first supplying the densest populated districts. The cost of erecting these four stations is estimated at 450,000 kronor, or \$125,000. While being available for the Radio Broadcasting Company during seven hours daily, the stations will, for the remainder of the day, be placed at the disposal of the Telegraph Department free of charge. The generally accessible program of the company comprises lectures, sermons, fairy tales for children, music, songs, general news, weather reports, time signals, etc. Actual advertising will be prohibited. Between 6 and 9 p. m., i. e., during the most important broadcasting hours, the Government will be entitled for about half an hour to broadcast such official information as it wants made known to the inhabitants of the country.

### Radio Public Impatient With Advertising Talks

(Continued from page 259)

I would be very glad to know your views on this matter.

Yours very truly,  
J. STRICKLAND KING,  
New York.

Editor, PRINTERS' INK:  
The writer has noticed, with much interest, your recent discussion as to advertising by radio broadcast.

The writer fully endorses your views and he is just as emphatic as you are that no advertising should ever be permitted by our broadcasting stations.

As publisher of the largest radio publication, the writer believe that he speaks with authority when he says that broadcast listeners resent advertising talks, no matter how veiled or how cleverly they are put over. As a matter of fact, one of the greatest dangers that is threatening the radio in-

## THE DEMCAL

### The Variable Condenser with a Straight Line—Wave Length Curve

Approximately zero capacity when plates are disengaged

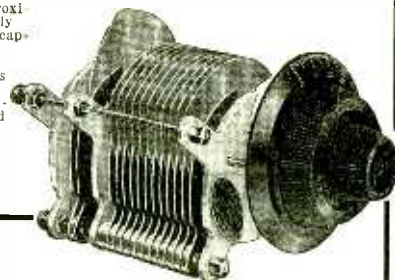

### RADIO ACHIEVEMENT

#### In the Straight Line—Wave Length Curve

|   |        |
|---|--------|
| 3 plate DEMCAL variable condenser .....       | \$2.50 |
| 11 plate DEMCAL variable condenser .....      | 3.50   |
| 11 plate DEMCAL variable vernier condenser .. | 6.50   |
| 23 plate DEMCAL variable condenser .....      | 5.00   |
| 23 plate DEMCAL variable vernier condenser .. | 8.00   |
| 43 plate DEMCAL variable condenser .....      | 6.50   |
| 43 plate DEMCAL variable vernier condenser .. | 10.00  |

**CALDBECK TOOL & MFG. CO.**  
208-10 E. Walnut St. Des Moines, Iowa

Coils and mountings licensed under DeForest patents

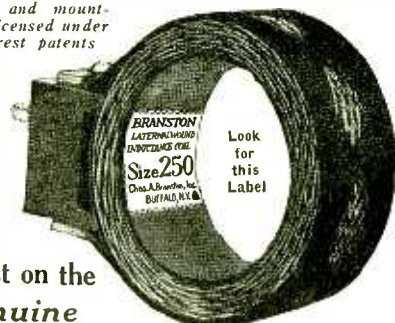

### Insist on the Genuine

Ask your "Old Timer" Radio friend why sets using Honeycomb Coils are best. Then ask your dealer for Branston Lateral Wound Honeycomb Inductance Coils and Coil Mountings. Branston Coils are protected from injury and can not come loose from mountings. Positive contact assured. Guaranteed uniform maximum inductance with minimum distributed capacity. Send 2c in stamps for Series I "Hook-Up" Circular showing five good Honeycomb Coil hook-ups and Catalog of Famous Branston Radio materials. Write today. Give us the name of your Radio Dealer. If he can't supply you, let us know.

**CHAS. A. BRANSTON, Inc.**  
817 Main St., Buffalo, N. Y.  
In Canada Chas. A. Branston, Ltd., Toronto, Ont.



**BRANSTON**  
RADIO

## RT-A 2

The Audio Frequency Transformer that gives you perfect Tone Quality and High Amplification without distortion. Moisture-proof—it is ideal for the seashore. Letters received every day state that RT-A2 passes every test and fulfills the most critical requirements of experts and amateurs.



Use RT-A2 transformers at once and enjoy better radio reception. Price \$6.50 at all good dealers.

**RASLA SALES CORPORATION**  
National Distributors  
Dept. A. 10 E. 43rd St., New York City

### Just In Time For All of the NEW CIRCUITS

## B-T UNIVERSAL VERNIER TUNER



**Price Post-paid \$5.**

### B-T. VERNIER TUNER

Replaces tapped coils and switches in the Reinartz and Ultra Audion Circuits, and improves reception wonderfully.

Takes the place of variocoupler in regenerative circuits with marked improvement in results.

Gives very fine vernier control when used as a variometer.

Adapted equally to all the old and new circuits.

Price, Postpaid \$5.00.

Ask your dealer or remit direct, sending dealer's name.

Free, photo diagram of new B-T Reinartz hook-up. Send 2c stamp or postage and name of your dealer.

**Bremer-Tully Mfg. Co.**  
Canal and Harrison Sts., Chicago

dustry right now is that the radio public is becoming impatient with such advertising talks and is not at all as anxious to listen in to lectures as it used to be when broadcasting originated a few years ago. Radio amateurs, that large body of purely radio experimenters, are doing all they can to discredit radio broadcast, just on account of this advertising phase, as they feel, quite rightly, that the great art of radio is being used for the furtherance of selfish interests.

The time is coming when our large broadcasting stations will be much more careful of what they broadcast, and while some of our big stations are censoring every word of all lectures, still we have a long way to go.

If broadcasting stations will confine themselves to indirect advertising, we believe that no one will take exception to this. By indirect advertising is meant the following:

Recently a German opera company which has been giving operas at the Manhattan Opera House, permitted one of the large broadcasting stations to broadcast an entire opera. This was a creditable undertaking, and hundreds of thousands of radio fans listened with great satisfaction to this opera. Previous to this the opera company was playing to almost empty houses. The very next day, however, the Manhattan Opera House was stormed by the very radio fans who had listened in the night before! The *New York Times* commented upon this in an article, and actual investigation proved that the unusual attendance was directly traceable to this broadcast opera.

The writer believes that in the future, opera, as well as musical comedies, dramas, etc., will be broadcast on a large scale, and that the producers will pay broadcasting stations handsomely to thus broadcast one or more acts of their productions. This is legitimate and not direct advertising, but the indirect results from such broadcasting are certain to be of inestimable value to our producers. The writer believes that this form of broadcasting is unobjectionable. On the other hand, all direct advertising, such as mentioning the names of wares even vaguely, should never be done, as it is certain to prove a boomerang sooner or later to the broadcasting stations.

"RADIO NEWS,"  
H. GERNSBACK, Editor.

### The All-Purpose Receiver

(Continued from page 277)

hand post and the minus lead to the center. A UV-200 or WD-12 tube can be used, or any of the other types with the proper adapters. Make sure that you have the correct "A" battery voltage, 6 volts for the former tube and 1½ volts for the latter. The plus "A" battery terminal goes to the center post and the minus to the left-hand post of the base panel.

All your tuning will be done with the variable condenser, a feature which greatly simplifies the operation and control of the set. While it might appear that a loss of efficiency would be caused by not having an adjustable primary inductance, actually no loss and some gain is obtained in actual practice. There are several reasons for this. Any tapped coil, particularly when units and tens switches are employed, has losses which are not found in the fixed coupler. In addition, a loss is caused in the secondary inductance by the presence of the ball which increases the radio frequency resistance and, consequently, broadens the tuning. Moreover, particularly at the higher wave-length adjustments, there is a voltage step-down between the primary and secondary rather than a step-up. In the fixed coupler there

## "The World is Mine!" MU-RAD RECEIVERS

THE thrill of great distances—that is the special privilege of MU-RAD owners due to the extreme sensitivity and delightful efficiency of their sets. Cities for thousands of miles in every direction, a dozen states, ships at sea, far-away Hawaii, Cuba and Canada—all contribute to their entertainment.

Requires only a two-foot loop aerial. Professional results for the most inexperienced because MU-RAD RECEIVERS are so simply operated.

Absolute guarantee of 1000 miles reception.

Write for Literature.

### MU-RAD LABORATORIES, INC.

801 Fifth Avenue, Asbury Park, New Jersey



### "Read'em" Binding Posts

With Knobs  
That Won't Come Off

Anyone can "read 'em." All popular styles—Antenna, Ground, Fones, A and B Battery plus and minus—abbreviations of different names engraved on knobs. Radio users—ask your dealer for "Read 'em." Dealers—write for our proposition on this big seller. Write Dept. A for liberal profit proposition.

The Marshall-Gerken Co.  
Manufacturers  
Toledo, Ohio

### Why Pay More?

GENUINE R.C.A. TUBES

W.D. 11 \$5.95 UV-199  
W.D. 12 \$5.95 UV-201A

ALL NEW, NO STAMPS, NO C.O.D.  
BALDWIN PHONES \$9.75

Send for our New Price List  
with many other items.

Save Money By Buying From Us

CUT RATE RADIO CO.  
P. O. Box 472 Newark, N. J.



**WALNART  
Trouble  
Proof  
RADIO  
Apparatus.**

**Walnart Trouble-Proof  
Variable Condenser**

Dependable, efficient, accurate. Original Walnart Stator Construction. Rotor plates held in fixed parallel by positive springs. End plates and Dials are genuine Bakelite. Vernier type—13, 23 and 43 plates. Plain type 3, 5, 13, 23 and 43 plates.

**Would You Buy Parts and Drill 10 Holes for \$1?**

Why spend hours of tedious work in drilling 10 holes in your panel and soldering 10 hard-to-get-at connections, when you can solder the entire

**Walnart Inductance Switch  
Assembly**

on the outside, and insert the completed job through one small hole in the panel?

Adjusting nut takes care of any thickness of panel. Results secured are fine!

And it costs only a dollar—at your dealers or from us!

Send for price list.

Try your dealer first. If he has not yet "seen the light" remit to us, and give us his name and address.

**WALNART ELECTRIC MFG. CO.**

1249 W. Van Buren St., Chicago, Ill.

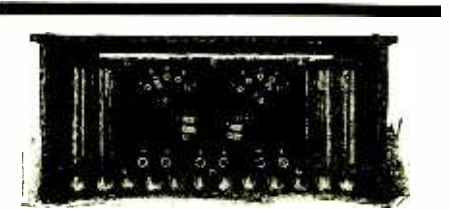

**KICO Storage "B" Batteries Give Long Service at Low Cost.**

Alkaline type, will not sulphate or buckle. Life unlimited. Not harmed by short-circuiting, overcharging, or standing idle. Panel switches afford single cell variations. Easily re-charged from any 110-volt A.C. line by means of small home rectifier. One charge lasts three to six months in detector plate circuit.

| Prices without rectifier: |       | Plain   | (With Panels) |
|---------------------------|-------|---------|---------------|
| 16 cell 22 volt           | ..... | \$ 5.50 |               |
| 24 cell 32 volt           | ..... | \$ 7.25 | \$11.75       |
| 36 cell 48 volt           | ..... | \$ 9.50 | \$14.00       |
| 50 cell 68 volt           | ..... | \$12.50 | \$17.00       |
| 78 cell 100 volt          | ..... | \$17.50 | \$22.50       |
| 108 cell 145 volt         | ..... | \$23.50 | \$28.50       |
| Unmounted rectifier       | ..... | \$ 1.00 |               |
| Mounted rectifier         | ..... | \$ 2.50 |               |

**Satisfaction Guaranteed**

All batteries are sold with the privilege of receiving your money back if not satisfied within a 30 day trial. Write for full information on "A" and "B" Batteries.

**Kimley Electric Company, Inc.**

2665 Main Street

Buffalo, N. Y.

is a step-up ratio, an advantage since the response in the telephones is approximately proportionate to the voltage applied to the grid. The result of these various effects, some favorable and some otherwise, is slightly in favor of the fixed coupler over the ordinary design of variocoupler.

**FIXED COUPLER AS EFFICIENT AS VARIABLE ONE**

An easy way to prove, for your own satisfaction, that a variable primary inductance is not necessary is to set the coupling control of a variocoupler type circuit at the normal operation position. Tune in a station, adjusting the primary switches and the secondary condenser until maximum signal strength is obtained. Then increase the primary inductance and readjust the secondary condenser. You will find that you can bring the signals back to their original setting. Move the switch below the original setting, adjust the secondary condenser again and you will find the signals coming in full strength. That is because the real tuning is done in the secondary circuit for the resistance of the antenna and ground is so high, particularly with a single wire antenna, that the primary tuning is very broad.

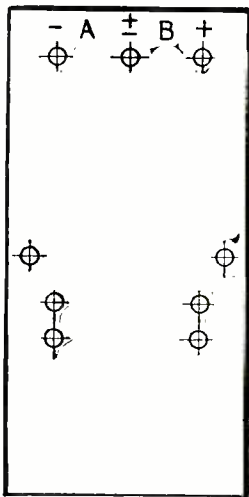

ALL HOLES NO. 18 DRILL  
Fig. 5

Layout of the Base Panel. This Is One-Half the Scale of the Original.

To make the set into a three-circuit regenerative tuner, remove the jumper from the VARIOM. posts and connect a variometer across them. You will then have the variable condenser to control the wavelength and the variometer to adjust the regeneration. This makes a very fine receiver, for it is highly efficient in operation and extremely selective in tuning. To operate the set, turn the tube at a little below normal brilliancy, set the variometer so that the circuit does not oscillate, and tune in the station with the variable condenser. Then, moving the condenser a little bit each side of the point at which the signals are loudest, increase the variometer until the set oscillates. That will destroy the quality of the speech or music. Note the exact point on the variometer scale at which the circuit started to oscillate. Turn the variometer back until the oscillation stops. Then increase the variometer again, moving the condenser back and forth slightly, at the same time, to just a half degree before the point at which the variometer caused oscillations to take place. You will then have the setting for maximum signal strength.

Some experimenters have had very good results with regenerative receivers having a plate variometer for regeneration control and a loop shunted by a variable condenser for the grid tuning circuit. To use the outfit in that way disconnect your antenna and ground and plug in the loop at the jack provided.



With drawer ... \$15  
With battery box \$17

**A RADIO TABLE**

Especially designed for the convenience and effectiveness of any radio set, and handsomely finished to harmonize with the furniture of the well appointed home.

Top 26 in. by 10½ in. Height 24½ in. Drawer for dry cell batteries with invisible connection at rear, or with roomy box for storage batteries.

Send money order and table will be expressed to you, or sent by express C. O. D. if you prefer. Write for photographs.

**RADIO FURNITURE CO.**  
FLUSHING, N. Y.

**HEADBANDS**



Simple friction slide adjustment. Most satisfactory on the market. No thumb screws to bother with or to catch in the hair.

Two yoke sizes fit any 'phones. Bands covered in Black or Khaki webbing.

Prompt deliveries on any quantity.

\$500,000.00 worth of special and automatic machinery assures quantity output and guaranteed delivery for manufacturers and dealers on any radio equipment.

Submit sample of product. Write for prices.

**THE AUTOYRE CO.**  
OAKVILLE, CONN.

**Parts and Accessories for makers of radio apparatus**

**GERACO**  
PROVED RADIO PRODUCTS

Details and Prices on request  
**GENERAL RADIO CORPORATION**  
Sole Distributors of  
**First Quality Radio Equipment**  
including **MUSIC MASTER RADIO**, Reproducer  
10th and Cherry Streets Philadelphia

**AMPERITE**  
AUTOMATIC FILAMENT CURRENT ADJUSTER FOR EVERY STANDARD TUBE  
ELIMINATES RHEOSTATS  
EXPELS ALL TUBE TROUBLES  
FROM YOUR DEALER OR  
RADIALL COMPANY \$110 WITH MOUNTING  
654 GRAND AVE., NEW HAVEN, CONN.

An efficient loop can be made by winding 15 turns of No. 18 annunciator wire on a frame work 2' square, spacing the turns by 1/2".

You will probably think up other experiments to make with this outfit while you are operating it. Additional information and data will be found in Parts 2 and 3 to appear in the coming issues of RADIO NEWS.

### A Radio Live Wire

(Continued from page 256)

things in a week. My pressure was up so high I feared I'd blow up while waiting, so I bought a "flivver" and on that have had built in a small way, what I will have when the big car is done. The little fellow is nicely decorated in red and gold; and is some looker. I am now "rarin' to go."

I am handling standard sets at this time. (Never mind the make). In starting this new plan, I want to have a set that can be sold, completely equipped, at about \$100: this is all the average farmer, and the general masses, can pay. Some of course can be sold complete sets at \$150, and there will be a limited number of sales at approximately \$200. These are the conditions that confront me. For a manufacturer who could sell on installment terms, I could do a great business, and make safe sales. I could sell the \$100 outfit, before mentioned, for \$125 or more—\$50 down, balance mortgage contract notes \$10 per month; but I cannot personally finance the proposition. I must have standard sets; licensed; simple to operate. I am selling to just common people—not radio experts and engineers. Now what have YOU to offer? I'll not sell trash, no matter what the profit. I've been a successful promoter and road salesman—not an "order taker." For over 17 years I have owned the Southern Printing Co. plant in this city. I have repeat customers in many states, as well as in Cuba, Mexico and Japan, and I keep them, because I always play fair. I keep their confidence and get their coin. I am in the radio game in the same way.

I don't know a blamed thing about the technical or scientific part of radio; but if a set "has anything in it" I DO know that I can get it out. And I can show my customer how to do it too. That means business, and more business. If you have the outfit I need, and a proposition to make, I'm listening. Although going on 70 years young I've got the "pep" as you will note. I expect an "out of the ordinary" proposition, for I shall produce results both surprising and pleasing. This letter is "something different" and if it interests you, as I feel it will, I shall look for a prompt reply.

Very truly, signing off,

O. H. HOVEY,  
Perry, Ok ahoma.

To Manufacturers of Parts and Specialties—If you have something you KNOW is the "real thing" you can't find a better way to introduce and push it, both to the dealer and user; for I first demonstrate to the dealer, and if he is too dead to stock up with a good thing, and a monkey gland won't put life into him, why I'll sell direct to the builder of his own, deliver on the spot, from stock carried, and get his coin. Better send me demonstration sample. Returned promptly if sales are not satisfactory to you.

#### RASH?

New Radio Bug (listening in): "Mother, I've got dots and dashes!"

Old-fashioned Mother: "You Fave! I'll call the doctor right away!"



## CONDENSERS

*Radiant Variable Condensers* exceed the standards of just "good condensers" by adding exclusive advantages which definitely establish these condensers as superior value. Warping of plates, which necessitated frequent realignment, was regarded as a necessary evil—until *Radiant Condensers* were made with permanently *FLAT*, non-warping plates. No re-adjustment needed during years of use. Prevention has replaced *correction* in *Radiant Condensers*.

### The Geared Vernier Adjustment

Since the purpose of the vernier adjustment on a condenser is super-fine adjustment—the importance of this improved vernier plate is evident at a glance. The vernier plate is geared to the adjusting knob as the parts of a watch are geared. Micrometer adjustment to the thousandth of an inch, with a slight, easy turn.

Radiant Condensers Can Be Bought at Good Radio Stores.  
Write for Illustrated Folder.

| Prices                                     |        |
|--|--------|
| VERNIER TYPE                               |        |
| 10 Plate including 2 1/2" dial and knob... | \$5.00 |
| 15 Plate including 2 1/2" dial and knob... | \$5.50 |
| 43 Plate including 2 3/8" dial and knob... | \$6.50 |

Write Immediately for Proposition,  
Jobbers and Dealers

## HEATH RADIO & Electric Mfg. Co.

206 First St.  
Newark, N. J., U. S. A.



**The Only Quality  
3000-Ohm Guaranteed  
Head Set for  
\$5.00**

**\$5.00**  
3000 Ohms

**TRUE - TONE RADIO MFG. CO.**  
188 No. La Salle Ave. CHICAGO, ILL.

# FREE

## RADIO CATALOG

of Standard Quality Parts  
AT REDUCED PRICES

Our Guarantee Protects You

## GREAT LAKES RADIO CO.

136 W. LAKE STREET, CHICAGO, ILL.

WANTED—Back numbers of Radio News, Sept., Oct., Nov. and Dec., 1921, Jan. and Feb., 1922. Experimenter Publishing Co., 53 Park Place, New York City.



**\$3 DOWN** brings genuine **UNDERWOOD**

Yes, only \$3 down puts this genuine standard Shipman-Ward Rebuilt Underwood in your home. Then—small monthly payments, or if convenient, pay cash. Either way you get the world's standard typewriter at a big cash saving.

**WHY PAY RENTAL?**

Think of it! You pay little more than rental, and the machine is yours! We offer the same three models of the Underwood Typewriter which are being made and sold by the Underwood Company today. The only difference is that Shipman-Ward machines are priced lower and are rebuilt like new by experts. You can't tell them from brand new machines. Visible writing—the FULL LINE of typewriting is visible at all times. STANDARD 4-ROW SINGLE SHIFT KEYBOARD. Two color ribbon, back spacer, stencil device, automatic ribbon reverse, tabulator, etc.

**TEN DAYS' FREE TRIAL**

See for yourself! Try the typewriter ten days. You must be satisfied or the entire transaction won't cost you a penny. Act today. Get our big illustrated catalog and full particulars. Write NOW.

---FREE TRIAL COUPON---

**Typewriter Emporium**  
**SHIPMAN-WARD MFG. CO.**  
1956 Shipman Bldg., CHICAGO

Send by return mail Bargain Offer No. 1956 of a Standard Visible Writing Underwood. This is not an order and does not obligate me to buy.

Name.....  
Street or R. F. D. No.....  
Postoffice..... State.....

### The McNoodle Brothers' Radio Mystery

(Continued from page 260)

tions he had heard. Each post-card said, "I heard your concert fine and it was grand." Orone certainly was the sort of fan that makes a broadcaster's heart happy.

Orone had only one peculiarity that amounted to much, but it was one that filled his life full and kept him busy day and night. He was a static collector. What I mean is that he collected static the way another fellow collects old postage stamps or Colonial furniture or first editions of books. He was trying to get a complete collection of statics. Summer he found was the best time for this because there is more static then. Some nights he hardly added one single new static to his collection, but other nights he would catch three or four. And he certainly was getting a wonderful collection. He had eighty-six distinct and different varieties of zizzes, and forty-two kinds of howls, and nineteen kinds of zangs, and he had pips and pops and zurrs and wees, and one splendid whang that he got one night in a thunder storm when the lightning struck his barn and burned out his lightning arrester.

As far as I know, Orone McNoodle was the only man in the world who really enjoyed getting so much static that he could hear nothing else. He was crazy for it. Whenever he heard of a hook-up that minimized static he reversed it, and hooked-up so as to get the most static. When he heard that a short antenna lessened static he lengthened his antenna to get more static. He had a book and in it he had written a lot of hook-ups and the title he wrote on the cover was "The Sixteen Statikest Hook-ups Known." Whenever he heard anyone say "My set is no good. I can't get anything but static," he would dig right down into his pocket and buy that set, no matter what it cost.

The way he kept his collection was by using phonograph records. He had a recording needle and soft records, and when static was coming strong, or he heard a new variety, he would point the loud-speaker of his set into the horn of the receiving phonograph and shout "No. 654. Yowl static. July 7, 1922," or whatever the date was. He kept all these records and tried them over and over on his phonograph, assorting them and getting all the yowls in one pile and all the zizzes in another, and so on.

It was Orone McNoodle's ambition to have every variety of static there could possibly be, and when he had phonographed every kind that could be secured from an outdoor aerial he turned his attention to indoor aeriels. It was Orone McNoodle who invented the McNoodle super-static indoor loop, which was guaranteed to equal any outdoor aerial in picking up static, and he made one of these that was so perfect that it received nothing but static. It gave down such a strong, two-fisted quality of static that it drowned even a Ridgewood jazz band and that, I submit, is going strong.

Well, when Orone had canned three or four hundred varieties of indoor loop static he felt that he had exhausted that phase of his collecting, and he looked for the next world to conquer. Fortunately, he read that an underground aerial—an aerial buried underground—gathered practically no static at all. So he decided to get to work and invent an underground aerial that would gather static wholesale and retail. He was always hoping to hit on something that would give him a kind of static he had never had before—one that would boom like a bass drum or sound like a skyrocket or a boiler factory, or something.



*A Twist of the Wrist* **IT'S SET**

## YELLOW TIP

MICROMETER ADJUSTING  
**CRYSTAL DETECTOR**

**Increases the Efficiency of Your Crystal Set!**

Finer tuning, clearest possible reception, constant adjustment until you wish to change, then—"A Twist of the Wrist—It's Set." Excellent for reflex and other circuits. Write for folder and name of your nearest dealer.

**2**

**WHOLESALE RADIO EQUIPMENT CO.**  
Exclusive Distributors  
38 WILLIAM ST., NEWARK, N. J.

Dealers and Jobbers write for attractive proposition.

*Ideal Summer Vacations*  
**BERMUDA**  
Only 2 Days from New York

8 Day Tours — \$83.00 and up  
9 Day Tours — \$88.50 and up  
**Longer Tours in Proportion**  
Including all Expenses  
**All Outdoor Sports**

Sailing, Bathing, Golf, Tennis, Crystal Caves, Sea Gardens, etc. Bermuda is Cool in Summer. Average Summer Temperature 77 deg.

No Passports Required  
**Sailings Twice Weekly**  
Via Palatial, Twin-Screw, Oil-Burning Transatlantic Liners

**S. S. "Fort Victoria" and S. S. "Fort St. George"**

For Illustrated Booklets on Bermuda Tours write  
**FURNESS BERMUDA LINE**  
34 Whitehall St., N. Y., or any Local Tourist Agent



**It's the contact that counts**

A careful examination will show that each contact in Na-ald sockets and adapters is of a wiping nature on a broad surface, and of sufficient tension, and so designed that tension is permanent, no matter how often the bulbs may be removed and how much the connecting prongs in the tubes vary.

It is little realized that sockets are being sold which, owing to faulty choice or control of material, develop current leakages from plate to grid that rob many otherwise well-made sets of their efficiency. Na-ald sockets in their design avoid all these troubles.

**NA-ALD SOCKETS**

|  |        |
|--|--------|
| No. 199 Socket, 199 tubes.....                 | \$0.50 |
| No. 129 Adapter, 199 tubes.....                | .75    |
| No. 100 De Luxe, 200 tubes.....                | .75    |
| No. 101 Small Spare, 200 tubes.....            | .37    |
| No. 111 W. D. 11 tubes.....                    | .75    |
| No. 150 Two in One, W. D. 11 or 200 tubes..... | .50    |

Booklet with diagram of Hazeltine's Neutrodyne Circuit and other selected circuits packed with each Na-ald product.

**Alden Manufacturing Co.**  
Manufacturers of Sockets for Every Tube and Requirement  
Dept. K 52 Willow Street  
Springfield, Mass.

NA-ALD De Luxe No. 400

**NA-ALD**

**MONTROSE CONDENSERS**

|                          |        |
|--------------------------|--------|
| 11 Plate Vernier.....    | \$2.20 |
| 23 Plate Vernier.....    | 2.55   |
| 43 Plate Vernier.....    | 3.55   |
| 11 Plate Condenser.....  | .75    |
| 11 Plate Condenser.....  | 1.20   |
| 23 Plate Condenser.....  | 1.75   |
| 43 Plate Condenser.....  | 2.00   |
| .00025 mfd. Bal. Vernier | 2.70   |
| .0005 mfd. Bal. Vernier  | 3.30   |
| .001 mfd. Bal. Vernier   | 4.00   |

**MONTROSE MFG. CO.**  
1200 Bedford Ave. Brooklyn, N. Y.

**DESIGN AND CONSTRUCTION OF AUDIO AMPLIFYING TRANSFORMERS**  
Radio and Audio Frequency Type

This book will be of great interest to all radio amateurs. The transformers have never before been described in print. The possessor of vacuum tubes cannot afford to do without this book. It will enable him to build the necessary amplifying transformers very readily. The book is printed on good paper and has an attractive cover in two colors. Paper bound. Size, 5 inches by 7 inches. Contains many illustrations, diagrams and working data.

Price 25 Cents Postpaid

**EXPERIMENTER PUBLISHING CO.**  
53 Park Place New York City



So Orone got an automobile cable, a heavy one, and forty or fifty old wine bottles, and a pick and spade, and went down cellar. With a can-opener he cut off the necks and bottoms of the wine bottles. His idea was to make a deep trench in the cellar and stick the bottles together, neck to bottom, and cement them thus with rubber cement. This would make a real fine glass tube insulation to run the automobile cable through. Then he would run a wire to his outfit and try it out.

Orone was down cellar working on this, with a candle to light him, when Betsy Phipps went up to the third floor in Philo Gubb's house to go to bed. She went to the window to pull the shade and her one eye—and it was a wonderful eye—caught the light of the candle in the McNoodle cellar. She put her head out of the window and stared, and she saw Orone McNoodle shovelling dirt into a trench, and her evil old mind flopped over twice and she thought of sinfulness.

"There!" she said to herself. "I thought so! Bootleggers and moonshiners!"

She did not wait a minute. She rushed downstairs and accosted Philo Gubb, and poured out her tale of the trench in the cellar and all her vile suspicions, and Philo Gubb sat right up and took notice. He went to the closet and put on a pair of rubber shoes and a black hat and a heavy black beard and went out into the night and knelt down by the McNoodle's cellar window and looked in. It was just as Betsy Phipps had said. There was Orone McNoodle shovelling dirt into the trench, and there were broken bottles scattered here and yon, and the whole thing looked bad.

Philo Gubb went straight to the proper authorities and swore out a search-warrant and gathered together two policemen, a marshal, one constable and three deputy sheriffs. To these he added four members of the New York State Militia, two members of the Westcote Volunteer Fire Department, the cop of the Society for Prevention of Cruelty to Animals on a motorcycle, and the second vice-president of the Westcote National Bank. He looked at his revolver to see that it was properly loaded and the posse proceeded to the home of the McNoodles. Philo Gubb knocked on the door.

"In the name of the law I command you to open up this door," he shouted.

"Who is it?" Orone McNoodle asked in a trembling voice.

"This is Mister Detective Philo Gubb, Grade 2 graduate out of the Rising Sun Correspondence School of Detectkating, and I'm here onto legal business," said Philo Gubb.

"I'm in my pajamas," said Orone McNoodle, "is there any ladies present out there?"

"Not from my best knowledge and belief," said Philo Gubb, "unless they're into disguise, and if so it's their own risk and peril, but if needful the City and State of New York and the Volstead Act and Constitution of the United States will permit the allowance of five minutes to put on your pants."

"Maybe I'd better," Orone said.

Mr. Gubb thereupon divided his forces into two equal parts and sent one-half to the back door while he remained with the rest at the front door. In a few minutes Orone McNoodle opened the door a crack.

"I been thinking this over," he said pleasantly enough, "and it seems to me you ain't got any right to enter in here. This is my house and home and domicile."

"I have provided myself with the possession of a search warrant which I hold here in my hand," Philo Gubb said, "and I have a legally lawful right to enter and go into your house."

So Orone opened the door. He was meek and gentle enough but at heart he was

# REMLER

## APPARATUS THAT RADIATES QUALITY



**Remler Socket Adaptor Type 499**  
For using C-299 or UV-199 Tubes in sockets designed for C-11 and WD-11 Tubes.  
**Price \$1.00**

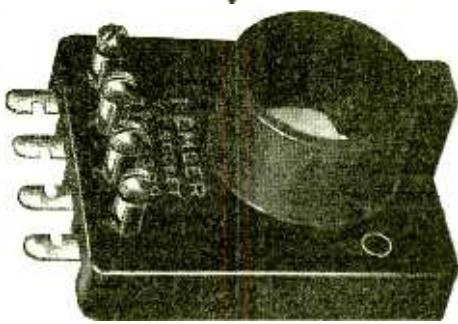

**Remler Dry Battery Tube Socket, Type 399**  
For Table or Panel Mounting, **Price \$1.00**



**Remler Socket Adaptor Type 599**  
For using C-299 or UV-199 Tubes in sockets designed for use with standard storage battery tubes.  
**Price \$1.25**

### Three New REMLER Items

of unquestionable merit, for use with C-299 and UV-199 Tubes

These three new appliances, a socket and two adaptors, for the C-299 and UV-199 dry battery tubes, are in every detail representative of *Remler Quality Apparatus*. They are perfect not only from the standpoint of manufacturing quality and appearance, but from the standpoint of mechanical and electrical design. Each of these items provides for the easy insertion of the tube in such a manner that it will not be jarred and become damaged, and have that strong positive contact so essential in any tube socket or adaptor to insure quiet and efficient operation of the circuit in which it is used.

We are pleased to recommend these three items to the public as being representative of the quality of all Remler apparatus. We are confident that your use of any of these articles will make you permanent Remler customers. Ask your dealer to show them to you, or write direct for our complete descriptive bulletin.

## REMLER RADIO MFG. COMPANY

Factory and Home Office      Eastern Sales Office  
248 FIRST STREET, SAN FRANCISCO      154 W. LAKE STREET, CHICAGO, ILL.

### FREE Radio Catalog



Our big stock of standard makes of radio sets, parts and supplies enables us to make prompt shipment from stock. Play safe—buy standard equipment from a reliable house.

No cut price material. Send \$1.25 for Univernier for close tuning—mention size of condenser or Variometer shaft; \$2.00 for 6-phone plug.

**Dealers—Build a Reputation**  
Every dealer should have our big illustrated catalogue of reliable apparatus. Write for it and our discount sheet.

**JULIUS ANDRAE & SONS CO.**  
In business since 1860  
117 Michigan Street, Milwaukee, Wis.

### Radio Supplies at Cut Prices

|  |        |
|--|--------|
| Western Electric "N" Peanut Tubes      | \$5.95 |
| Brandes or Federal Headsets            | 3.75   |
| Murdock or Diamond Headsets, 2,000 ohm | 3.95   |
| Federal Audio Transformers             | 3.25   |
| Acme Audio or Radio Transformers       | 3.85   |
| Jefferson Audio Transformers           | 3.75   |
| Ames Audio Transformers                | 2.75   |
| 2 1/2 Volt Variable B Battery, Small   | .90    |
| 2 1/2 Volt Variable B Battery, Large   | 1.75   |
| 45 Volt Variable B Battery             | 2.50   |
| No. 763 Eveready Variable B Battery    | 1.25   |
| No. 766 Eveready Variable B Battery    | 2.25   |
| No. 767 Eveready Variable B Battery    | 3.95   |
| 43 Plate Variable Condensers           | 1.85   |
| 23 Plate Variable Condensers           | 1.65   |
| Glass Enclosed Crystal Detectors       | .50    |

ALL MAIL ORDERS MUST INCLUDE POSTAGE

Kensington Radio Supply Co.

4417 18th Ave.      BROOKLYN, N. Y.

WANTED—Back numbers of Radio News, Dec., 1921, Jan. and Feb., 1922. Experimenter Publishing Co., 53 Park Place, New York City.

# GUARANTEED

Supreme To Any of Its Type

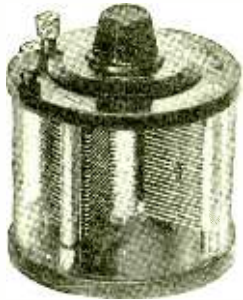

With You as a Judge

If not satisfied that it is Better than the Best, you can return within 10 days from purchase and receive full amount of purchase cost back.

"Certified" American Bell Condenser

A wonderful instrument of mechanical perfection.

Endorsed by radio engineers, journals and fans, from all over the U. S. A trial will mean a most marvelous surprise to you in radio satisfaction.

Don't delay trial—Send at once  
You are absolutely guaranteed.

43 Plate Variable Condenser complete with Dust Proof Transparent Case... **\$5.50**

23 Plate Variable Condenser complete with Dust Proof Transparent Case... **\$5.00**

State it for Panel or Desk Set.

American Bell Radio Corporation  
316 75th Street  
Brooklyn, N. Y.

The choice of foremost Engineers for over 17 years.

Sold by all dealers

**BRACH**  
VACUUM  
RADIO PROTECTOR

Approved by the National Board of Fire Underwriters  
Ask YOUR Insurance Agent

L. S. BRACH MFG. CO.,  
Newark, New Jersey

**SOLDERALL**  
Metal in Paste Form

Handy Tubes  
Every Electrical Connection Needs Solderall for Perfect Reception  
The Only Convenient Metal Solder

peevish, for he had been trying out the static of his buried antenna, and a thunderstorm was threatening, and this untimely interruption might prevent his getting some first class static to add to his collection.

"Well, what is it?" he asked.  
Philo Gubb paid no attention to him. Holding his revolver straight before him he walked through the hall to the kitchen and opened the cellar door.

"I give notice and warn!" he shouted. "I am coming down into this cellar onto the business of the law! I have a revolving pistol into my hand and it is loaded up in full and complete style and fashion, and if there is any resisting opposition I'm going to shoot it off."

No one answered from the cellar because there was no one down there. At the head of the backstairs leading to the floor above Fenix McNoodle appeared, with Mrs. McNoodle's head seemingly under his arm, as if he was carrying her that way.

"What's the matter down there?" he asked.

"These folks——" Orone McNoodle called up the stairs. "They're going to dig in the cellar."

"Oh, fudge!" Fenix McNoodle said disgustedly, and he went away from the head of the stairs, because he was not like Orone—he did not wear pajamas, he slept in a nightgown and he knew he was not exactly chaste and beautiful as he stood there in his bare legs.

Philo Gubb now ordered his backdoor posse to divide in two, one-half remaining where it was and the other half going to watch the front door, and with his force he went down the cellar stairs. What he saw was most suspicious. There was the newly dug earth that Orone had flung into the trench; there were the spade and pick; there were necks and bottoms of bottles. He picked up the spade and stuck it into the soft earth of the trench.

"Now, here! Here, now!" Orone McNoodle complained. "You don't want to do that! That's where I've got my aerial buried."

"I don't know what you mean," Philo Gubb said. "Aerial hasn't got no meaning that I'm acquainted with."

"It's a wire," Orone said. "An aerial is a wire they put up in the air to get radio with."

Philo Gubb straightened up and eyed Orone severely.

"Yes!" he said sternly. "Yes! I have visibly seen aerial wires up into the air from houses and barns and from trees and posts and onto the tops of buildings, et cetera and so forth. Yes! But I never heard of an aerial air wire being buried down into the ground. It ain't good sense. There ain't no sense into it whatever. Eagles and hawks and airplanes and weather-vanes and aerial air wires belong into the air and should be there, and not into underground trenches in cellars. Into the beneath part of the earth the things that belong are bottoms of fence posts, water pipes, potatoes and—lawless hooch! Yes, Orone McNoodle, lawless hooch!"

It was in vain Orone McNoodle pleaded. It was in vain he tried to explain that he was a collector of static. Several of the men in Philo Gubb's posse were radio lovers and what Orone McNoodle said seemed to them utter nonsense if not a wicked attempt to defeat the law. For weeks most of them had been trying to get rid of static, and the idea that any man should try to collect static seemed to them ridiculous.

"The man is not only a bootlegging crook but he is mad," one of them said.

It was then that Orone McNoodle turned to the Second Vice-President of the West-cote National Bank. Orone McNoodle knew the Second Vice-President because he had once tried to borrow money at the bank—

World Radio Batteries  
**SAVE YOU 50%**  
WRITTEN 2YR. GUAR.

**SATISFACTION GUARANTEED**  
We maintain the same high quality material and workmanship found in the most expensive batteries and still are able to allow our remarkably low sale price by greatly reducing our overhead and sale costs.  
Thousands of users enjoy the dependable qualities of our battery. World Battery owners "tell their friends." This is our best proof of performance.

**SPECIAL 2 VOLT for W. D. II — \$5.00 Will Run 200 Hours On One Charge.**  
**ORDER TODAY**—We ship C.O.D. subject to inspection or will allow 10 per cent. for cash with order. **WRITTEN 2-YEAR GUARANTEE** to each purchaser. Save 50 per cent. on your next battery and get better service and longer life. **Special Summer Offer**—Just clip this ad, mail in with your order and we will include one Free "B" Battery, free of charge. Write today—NOW.

**WORLD BATTERY COMPANY**  
Dept. 10  
1219 S. Wabash Ave., Chicago, Ill.

|                    |         |
|--------------------|---------|
| 6 volt 60 Amps...  | \$10.00 |
| 6 volt 80 Amps...  | 12.50   |
| 6 volt 100 Amps... | 14.50   |
| 6 volt 120 Amps... | 16.00   |

# static?

John A. Burrichter, 207 E. Ohio St., Indianapolis, Ind., writes:

"My set is about ten blocks from one of the local stations and when they started broadcasting, it meant that ended everything for the evening. After your Wave Trap was installed, they were tuned out completely."  
"I had expected with the approach of warm weather to take down my set until next fall, but while other local listeners in' are almost entirely out of my STATION, I am enjoying the programs just as much as in the cold months."  
"I have covered distances that heretofore have been impossible and really consider the Wave Trap the greatest invention since radio."

The Original **\$8.50** Prepaid  
**Wave Filter**

use **FERBEND**  
**Wave Trap**  
TRADE MARK  
PATENT APPLIED FOR

25 E. SOUTH WATER ST.  
**CHICAGO**

**EISEMANN**  
RADIO UNITS  
Made to the highest electrical and mechanical standards.  
**EISEMANN MAGNETO CORP'N**  
Chicago BROOKLYN, N.Y. Detroit

**CHARGE YOUR BATTERY**  
(RADIO OR AUTO)  
at HOME for a NICKEL  
**The HOMCHARGER**  
POPULARLY PRICED — PAYS FOR ITSELF  
SEND FOR THE AUTOMATIC ELECTRICAL DEVICES CO. FREE BOOK, 118 W. THIRD ST. — CINCINNATI, OHIO.

and had been turned down—and to him he repeated his story of the static collection. He led him upstairs and played ten or twelve statics on the phonograph for him, and the Second Vice-President was convinced that Orone was telling the truth. He led the way to the cellar again.

Philo Gubb and his helpers had just reached the bottle insulation. They were perspiring and had paused for breath and to wipe their brows.

"Listen, gentlemen!" said the Second Vice-President. "I have been upstairs and I have heard Orone play part of his static collection on his phonograph. It is all just as he says. He does collect static. This is indeed an underground aerial and nothing more. Mr. Gubb, that good woman, your housekeeper, has let her suspicions run away with her. This is only an innocent diversion of an honest and harmless man. You are wasting your time here."

"A detective has to waste a considerable good deal of time," said Philo Gubb solemnly, "and oft times the wasting of time is the most useful thing he does. Into the present case, however, I guess maybe I have been into a mistaken error, and if I have put you into any inconvenience, Mr. McNoodle, I am much obliged to you."

With this graceful apology Mr. Gubb and his forces departed and Orone McNoodle picked up the spade and began filling the trench again. As he bent his back to this job Fenix McNoodle came to the head of the stairs.

"Are they all gone?" he asked Orone.

"Yes," Orone replied.

"And did they find the hooch?" asked Fenix anxiously.

"No," said Orone cheerfully. "They stopped digging when they came to the underground aerial. But it was a close shave!"

And that's the end. And all I have to say is that there was no excuse for Philo Gubb not being even more suspicious. He should have known. When any man really likes static he needs looking into. There's something wrong with him.

### Radio Control In Great Britain

(Continued from page 248)

It is estimated that 200,000 individuals are using sets without licenses because they cannot secure the licenses they desire.

#### RADIO SITUATION IN IRELAND

No definite policy has been announced by the Irish Government up to April 1 regarding its position with respect to wireless broadcasting, or the operation of private receiving sets. There is a small market for this class of equipment, which, since the regulations of the British post office and the British Broadcasting Company do not apply in Ireland, is open to foreign manufacturers.

#### SUMMER PARK CONCERTS TO BE BROADCAST

Although the broadcasting of the Government's band concerts by NAA, Arlington, will cease during the summer months, radio fans within several hundred miles of Washington will be able to pick up some concerts if the plans of the Chesapeake and Potomac Telephone Company are carried out.

By June 15, this company now hopes to complete its new station in Washington and start broadcasting the open-air public concerts from the White Lot and local parks where the Marine, Navy and Army Bands will play almost daily.

# Brandes



## One every ten seconds

Production is the principal governing factor in determining costs.

The popular demand for Brandes Matched Tone Head-Sets has caused the installation of so many special machine tools and other labor saving devices that a substantial reduction of cost has resulted.

This we pass on to the consumer in lowered prices. The standard of Brandes quality will ever be maintained or raised if possible—checked by 22 rigid tests and inspections of each head-set.

Made in Canada and England by  
Canadian Brandes, Limited, Toronto and London

C. Brandes, Inc. - 237 Lafayette St., N.Y.C.

# Matched Tone Radio Headsets

TRADE MARK REG. U.S. PAT. OFF.

### Precision Resistance Unit



**EXTREME ACCURACY, CLARITY  
INSURES SILENT OPERATION**

Correct resistances of known value must be used for clear, distortionless reception. Each unit individually calibrated. Our interesting discount schedule is yours for the asking.

**THE DAVEN RADIO COMPANY**  
144 Bleecker Street Newark, N. J.

### Rainbow Multi-Plug & Cable



Put this type on your new set it is small and may be mounted anywhere with cord and plug \$4.00 Type P.M.

Put this type on seven binding posts of your present set. With cord and plug \$5.00 Type B.P.



Put your Batteries on shelf in basement and run this 8 ft. cable through floor to set.

5A and B. Battery wires in cable. Antenna and ground are separate leads from cap. Guaranteed not to impair efficiency of set. For sale by all Jobbers and Dealers. Fully covered by patents applied for. Manufactured by  
**HOWARD B. JONES**  
608 S. Canal St. Chicago, Ill.

## Hear them all, all the time



Don't miss a program  
Charge your  
A and B Batteries at  
home with a  
**Valley**  
Battery Charger

### Simple:

Plugs in on a light socket just like a lamp. Clamps to battery terminals.

### Safe:

Cannot overcharge your battery. Ammeter immediately indicates incorrect connections.

### Quick:

Will charge the ordinary radio battery from bed-time one night to listening-in time the next.

At radio dealers—or write us,

**Valley Electric Co.**  
St. Louis, Mo.

WOI WMC WDAP KDYX PWX

Through the aid of a new portable "input apparatus" recently perfected by the telephone engineers, the C. & P. Company expects to furnish the added "juice" necessary to pick up concerts and transmit them by wire to their station for radio broadcasting. This apparatus is mounted on a motor truck and can be dispatched anywhere in the city where something is to be broadcast.

Representatives of the company say that it is also sometimes difficult to relay speeches and music from private residences via telephone lines to broadcasting stations due to lack of current, but with the new "booster" they expect to overcome this handicap.

Important speeches and some concerts will also be put on a land line to New York and broadcast simultaneously from WFAF on a different wave length, telephone officials state.

## Radio Pays Its Debt To Dr. Alexanderson

(Continued from page 247)

his father and mother in Schenectady.

The successful use of radio in the Alexanderson case has convincingly proved the value of radio broadcasting as a publicity factor when far-reaching results are desired in a short time. WGY announced the kidnapping within two hours after it had been reported to the police. Other broadcasting stations joined their voices to the voice of WGY, and the story with descriptions of the missing boy and kidnapper, went out over the entire country. Radio fans everywhere were enlisted in the search. The newspapers kept them posted on the progress of the case and also furnished them with pictures of the boy. Through Hudson Maxim, the members of the Amateur Radio Relay League took up the case and hundreds of spark sets flashed the story through the air.

Dr. Alexanderson made a personal appeal from the Schenectady broadcasting station and after the boy had been found he again addressed the radio audience, thanking all for their interest, sympathy and assistance. He placed special emphasis on the co-operation of press and police.

Dr. Alexanderson has done much for radio, but the engineer feels that radio has more than repaid him for his work, for it has restored happiness to his home.

## Radio Telephony For Rural Districts

(Continued from page 246)

possibilities of the higher radio frequencies below the one meter wave-length is a field which is yet to be explored. While on the subject of waves, it should be noted that on these low waves the effects of static are almost nil and that they are also especially adapted to low-powered sets.

The only real objection in the realm of radio telephony which has held up its progress in the direction of intercommunication has been the lack of automatic signaling. The experiments carried out at Ohio State University have convinced the writer that the radio bell is an accomplished fact. It is true that at this early stage of development it is necessary to keep high-powered detector and amplifier circuits in constant use. But let us consider this point in the light of other facts; the country gentleman of today usually has his house lighted with direct current electricity supplied locally on his own estate by water power or gasoline, and the wattage for three five-watt tubes is about equivalent to one incandescent

## The H. K. Switch



Pat. Pending

The H. K. Multipoint Switch does away with the difficulty of drilling holes in a panel for switch points, only takes a few minutes to mount. Assures good contact. Is neat in appearance. Contacts are arranged so wires can be attached with ease. 2 1/2 in. Dial, calibrated to show contact in use.

**PRICE COMPLETE WITH DIAL \$2.00**

Awarded Certificate of Merit 38  
by Radio News Laboratories.

Do not receive postage stamps.  
Be sure to send enough Extra money to cover postage.  
Special prices to Dealers and Jobbers.

**KNOOP & PENCE CO.**  
PEOTONE, ILL.

## Our Latest Triumph



The  
**Michigan**  
**"Midget"**  
**\$27.00**

**Long-Distance Wonder Worker**  
**That Tunes Out Local Broadcasting**

**T**HE most dependable long-distance Receiver ever assembled in so small space. Convenient for campers and tourists, yet equally suited to home use the year-round. Handsome mahogany finished cabinet 14 1/4 in. long, 7 3/8 in. high, 9 3/8 in. deep at base.

Operates with any of the dry cell tubes as well as with standard 6-volt tubes. Cabinet will hold three No. 6 dry cells and 22 volt "B" Battery.

Levers in place of dials makes tuning easier and accurate. Wonderfully clear, pure-toned reception through head phones—add two-stage amplifier for loud speaker reception. A Radio Engineering triumph.

Price without tubes or batteries, F. O. B. Grand Rapids, \$27.00.

Ask your dealer. If he cannot supply you, remit to us and send his name and address.

Send for list of Michigan Quality Radio Receivers and Parts

**MICHIGAN RADIO CORPORATION**

GRAND RAPIDS, MICH.

## F. D. PITTS CO.

(Incorporated)  
RADIO MERCHANDISE  
WHOLESALE EXCLUSIVELY  
219 Columbus Avenue,  
BOSTON, MASS., U. S. A.

## KENNEDY

The Royalty of Radio

See your dealer for demonstration of Kennedy receiving sets or write us for descriptive literature.  
**THE COLIN B. KENNEDY CO.**

Saint Louis

San Francisco



**RIGGS RECTIFIER R**

**\$12.50**

Prepaid  
Anywhere  
in the  
U. S.

### Money Back Guarantee

We guarantee the Type B-3 to please you. If it does not, return it and we will return your money.

**THE RIGGS MFG. CO.**

Eastern factory Urbana, Ohio  
Western factory Everett, Wash.

lamp, and in the course of a very short time a vacuum tube will be practically as cheap as an ordinary lamp. Furthermore, in the course of developments, of radio signaling, the writer expects to see a master detector tube operating a slow-acting relay which would obviate the use of all but one tube except when a call is being received.

Before leaving the question of objections, the writer would like to anticipate another question which always comes up; the question of cost and equipment. To form a graphic picture of the difference between the cost and bulk of radio and the cost and bulk of adequate wire communication, when away from the beaten path, the following comparison is presented. In the case of the man living five miles away from a regular company's pole line, picture to yourself 150 telephone poles with brackets, guy wires, coils of line wire and the attachments piled up in the front yard of a country residence. Along side of this on a table, place the amount of radio equipment for a ten-watt radio set, including the amount of wire and attachments for an antenna. Just visualize to yourself the difference in bulk between the two systems. And as to cost, consider that the bill for line construction for such a line is over a thousand dollars, in addition to rental charge of about \$40 a year, while \$500 would cover the most elaborate type of radio set. It should be evident, therefore, from an economic point of view, as well as other considerations, that there is a real call for radio telephone development in the country districts. Aside from the above think of the artistic improvement to beautiful country roads which are now made unsightly by gaunt telephone poles.

**THE CALLING DEVICE**

We will now give a brief description of the radio bell used at the War Department demonstration. The general principles of wiring for this bell are similar to those discussed in the July issue of this magazine. A microphonic relay is used in series with an eight-volt battery and the primary of a transformer. The bell is wired to the secondary. It was noted with this hook-up that at the make and break of the contacts there was a noticeable kick back to the diaphragm of the microphonic relay although there was no physical connection between the relay circuit and the primary contact circuit. Since this only happened when the detector was in circuit it was decided that this reflex action was analogous to an oscillatory discharge, and that it was set up by the high back EMF of the transformer coils at the moment of sparking of the contacts. It was found that this so-called oscillatory discharge is picked up by the local radio system, detected, and returns to the relay as a regenerated impulse, adding its power, and imparting a more positive action to the diaphragm. In other words when the microphonic relay is in operation and the contacts are sparking, it is like having a small highly damped open spark gap station operating in the immediate vicinity of the regular receiving set and assisting in operating the relay, and therefore the bell. Inasmuch as this action actually did take place we designed a special contact to take advantage of this principle. It was made so that it would lay firmly against the diaphragm but yet would be held so lightly that the slightest motion would cause the contact to spark; a very fine steel wire was used to hold the contact in place. When the impulses were coming in from the transmitting station at the proper bell frequency (16 cycles per second) the bell rang as loudly and as sat-



# A new battery charger, noiseless and indestructible

**FANSTEEL BALKITE**

is a new metal developed for this charger. It acts as a valve, allowing alternating current to flow into the battery but not out of it. It is the most efficient charger valve made, is practically indestructible, and does away with noisy, delicate vibrators and fragile bulbs.

The Gould Battery Company is also marketing, under the Fansteel Balkite Patents, a complete battery and recharging unit known as the Gould Unipower, into which this charger, under the name, "The Fansteel Balkite Rectifier," has been incorporated.

The Fansteel Balkite Battery Charger for Radio "A" Batteries is an entirely new type of electrolytic rectifier, based on the use of Fansteel Balkite, a new and rare metal developed for this purpose. It does away with all noise, cannot deteriorate through use or disuse, has nothing to replace, adjust, or get out of order, cannot discharge or short circuit the battery, and requires no attention. There are no moving parts, bulbs, or fuses. It will not overcharge, and cannot fail to operate when connected to the battery and line current. It is unaffected by temperature or fluctuations in line current, and will charge a completely dead battery. It is simple, efficient, and indestructible except through an abuse.

*This charger can be operated while the set is in use without affecting the set or its operation, and without disturbing noises.*

**FANSTEEL**  
**Balkite**  
PATENTS APPLIED FOR  
**Battery Charger**

The Fansteel Balkite Battery Charger will charge the ordinary 6 volt radio "A" battery at 3 amperes, and a 12 volt at 1½ amperes, from 110 AC, 60 cycle current. It comes complete and ready for use. Get it from your dealer, or use the coupon below.

**Price, \$18**

\$18.50 West of the Rockies

FANSTEEL PRODUCTS CO., Inc., No. Chicago, Ill.

Dealers and Jobbers: The Fansteel Balkite Battery Charger does away with complaints and replacement troubles. Write for literature and discounts.

Dept. 4A

FANSTEEL PRODUCTS Co., North Chicago, Ill.

Enclosed please find \$18. (\$18.50 west of the Rockies.) Send me the Fansteel Balkite Battery Charger for Radio "A" Batteries. If I am not entirely satisfied I will return it and you will refund my money.

Name .....

Street .....

City..... State .....



**Loud Speaker Quality**

Years of experience were required to perfect the acoustics of a victrola. It will only cost a small amount to make your Victor Talking Machine a RADIO LOUD SPEAKER, with a "Beeko" Radio-Phone attachment. Sample by mail 40c. Send stamp for catalog 45-B. Liberal discount in quantities.

**J. H. BUNNELL & COMPANY**  
32 PARK PLACE NEW YORK

**BROWNLIE QUICK CONTACT**

Reg. U. S. Pat. Off. CRYSTAL

**A NATURAL MINERAL FOR YOUR SET**  
Your catwhisker contact can move over the entire surface without loss of programme. Fourteen years of Crystal making now give you the World's best product for all uses, Reflex, Radio Frequency or Crystal Receivers.

Price Mounted and Guaranteed **30c each**

Order from your dealer or sent Postpaid on receipt of coin.

**RONALD BROWNLIE, Manuf'r**  
22-24 Saunders Street Medford, Mass

Insure your copy reaching you each month. Subscribe to Radio News—\$2.50 a year. Experimenter Publishing Co., 53 Park Place, N. Y. C.

# W. L. DOUGLAS

**\$7.00 & \$8.00 SHOES** FOR MEN AND WOMEN

ALSO MANY STYLES AT **\$5.00 & \$6.00**

W. L. DOUGLAS SHOES ARE ACTUALLY DEMANDED YEAR AFTER YEAR BY MORE PEOPLE THAN ANY OTHER SHOES IN THE WORLD



They are made of the best and finest leathers, by skilled shoemakers, all working to make the best shoes for the price. The quality is unsurpassed. The smart styles are the leaders in the fashion centers of America. The wide range in kinds, styles and prices provides suitable shoes for every occasion, business, travel and motoring. Shoes of equal quality cannot be bought elsewhere at anywhere near our prices.

If you have been paying high prices for shoes, why not try a pair of W. L. Douglas \$8.00 shoes, the shoes that hold their shape? They are exceptionally good value. Frankly, is it not worth while in these days of high cost of living for you to save money on your footwear when the opportunity offers?

For thirty-seven years W. L. Douglas name and portrait have stood for a high standard of quality and dependable value. For economy and satisfactory service, wear shoes that bear this trade mark. Ask your dealer for W. L. Douglas shoes. Look for W. L. Douglas name and the retail price stamped on the sole. Refuse substitutes.

IF NOT FOR SALE IN YOUR VICINITY, WRITE FOR ILLUSTRATED CATALOG SHOWING HOW TO ORDER SHOES BY MAIL. POSTAGE FREE. 172 Spark Street, Brockton, Mass.

**TO MERCHANTS:** If no dealer in your town handles W. L. Douglas shoes, write today for exclusive rights to handle this quick-selling, quick turn-over line.

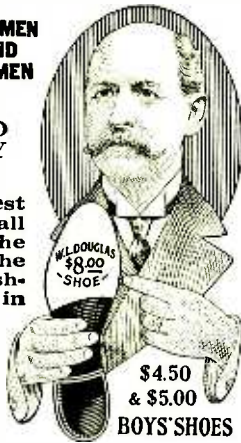

*W. L. Douglas*  
President

ESTABLISHED 1876

## PATENTS TRADE-MARKS AND COPYRIGHTS

Before disclosing an invention, the inventor should write for our blank form "RECORD OF INVENTION". This should be signed and witnessed and if returned to us together with model or sketch and description of the invention we will give our opinion as to its patentable nature. Radio and Electrical cases a specialty.

Our illustrated Guide Book, "HOW TO OBTAIN A PATENT," sent Free on request. Highest References Prompt Attention Reasonable Terms

FREE COUPON

VICTOR J. EVANS & CO., Patent Attorneys

Chicago Offices: 1114 Tacoma Bldg.

Pittsburgh Offices: 514 Empire Bldg.

Philadelphia Offices: 714-715 Liberty Bldg.

San Francisco Offices: Hobart Bldg.

NEW YORK OFFICES: 1001 Woolworth Bldg.  
MAIN OFFICES: 919 NINTH, WASHINGTON, D. C.

Name ..... Address .....

## PATENTS If You Have an Invention and Desire to Learn How to Secure a Patent

Send for our Free Guide Book, HOW TO GET YOUR PATENT. Tells our terms and methods. Send model or sketch and description of your invention and we will give our opinion as to patentable nature. Our documentary

**PROOF OF INVENTION** is intended for your protection and will be sent you without charge. Write for it.

**RANDOLPH & CO.**

Dept. 459 Washington, D. C.

NAME .....  
STREET .....  
CITY ..... STATE .....

## PATENTS

C. L. PARKER  
Formerly Member  
Examining Corps,  
U. S. Patent Office.  
PATENT - LAWYER  
McGill Bldg., Wash., D. C.

Patents, Trade Marks, Copyrights, Patent Litigation  
Handbook for Inventors. "Protecting, Exploiting  
and Selling Inventions." sent upon request.

## PATENTS

Send sketch or model today for examination and report. Record of Invention blank on which to disclose your invention and new guide book, "How to Obtain a Patent," sent free. Promptness assured. Highest references. WRITE TODAY. CLARENCE A. O'BRIEN, Registered Patent Lawyer, 1051 Southern Bldg., Washington, D. C.

isfactorily as on one's own telephone. As a matter of fact the signal quality of the bell was tested by taking the inspectors into a room, separated from the set by two walls, where bell was still audible. While the bell is in operation the primary circuit is drawing only .7 of an ampere on an eight-volt battery, while the secondary is generating 34 volts A.C. The above facts are interesting in connection with differential radio control using relays and electrically tuned circuits.

### THE SET USED IN THE EXPERIMENTS

We will here give a short discussion of the Army SCR 77 set. Our reason for this discussion is that this set has a number of features which make it interesting in connection with radio development for rural districts. It is the smallest of the army field radio sets in use and can be carried by two men. The outstanding features of this set, relative to the present article, are that the three tubes used in this set serve the combined purposes of a transmitter and receiver at the same time. This is a C.W. telegraph set. The circuit is not open for general publication but members of the organized Signal Reserve Corps and University students of the R. O. T. C. may become familiar with the set by securing "Radio Communications Pamphlet No. 6," prepared by the office of the Chief Signal Officer. This set uses a small one-turn loop antenna about two and a half feet in diameter consisting of a brass rod about 1/2" in diameter. Three receiving tubes (Type VT 1) are used, with 120 volts for transmission, and 40 volts for detection and amplification. The first tube has the combined function of a high frequency generator and a detector at the same time. By the heterodyne principle the two sets transmit and receive simultaneously, the transmitting operator hearing his own signals he breaks by opening the key circuit, thereby stopping the heterodyne. The maximum range of this set with a wave band covering two meters from 72 to 74 meters is five miles. On this seemingly narrow band nine distinct telegraph communications can be carried on without interference. Last summer at Camp Vail during the summer encampment the Ohio State University students experimenting with this set adapted it for use with voice. Magnetic modulation of the loop circuit was used, and also a transmitter was inserted in the place of the telegraph key (the latter system giving better results). In the light of these facts the writer has submitted the attached diagram combining the principles of radio: telephony and automatic signaling (see wiring diagram). This diagram is merely submitted as a starting point or working basis to begin with. The writer recognizes that the real radio bell of the future will be as different from the one in question as the audion lamp differs from the early coherer. But in all great developments there must be a start, and the principles of that start must be simple and practicable, a readaptation of present-day methods.

In concluding, the writer foresees the development of radio telephony as a regular means of communication in isolated districts. He looks for this development first as a hobby among the men of leisure of the country districts. Radio, with voice modulation, is now within the reach of the man who formerly had neither time nor inclination for code. Low cost of radio in comparison with the high cost of construction of wired communications, when away from the beaten path, is the incentive. When one recalls the crude "horseless carriage" of twenty-five years ago and compares it with the

modern limousine one has faith in the persistence of that ever-present class of experimenters who find pleasure in making realities out of dreams.

One can conjure in the imagination the following: a telephone bell ringing in the living room of a country residence. A servant lifts the receiver as is the practice with wired circuits, and answers the call from a distant point. It has come by wire to the telephone exchange of a nearby town, has been transferred to the radio section of the exchange and transmitted into the ether. It is picked up at the residence by a vertical cage antenna; an artistic rigged metal tower erected at the side, or on the roof of the house. The radio equipment proper is located in a room in the basement near the Delco lighting system. Other homes in the neighborhood are similarly radioed, each one having its own wave or party wave, and the wave-lengths are fixed. Each set is in tune with a calling device in the radio section of the telephone exchange. For local purposes communication is by radio, that is a neighbor first calls the exchange and is reconnected by radio to the neighbor called. The connection at the telephone office for this purpose, from one wave to the other, is by remodulation (Arlington time signals on 2500 meters rebroadcast by KDKA on 360 meters.) If the call is from a distance, it is carried by wire to the telephone exchange as mentioned above, shot it to the air as it is now being done at Catalina Islands, California, and relayed by radio the rest of the way. Those who can afford it have private waves; others have party waves. There is a conspicuous absence along the country side of ungainly poles. In the winter season when sleet is bearing down wired circuits and the wind comes along and blows them into a tangled mass on the ground, the radio system is enjoying immunity from the storm. This dream is separated from being an actuality merely by the creative genius of the American public. This creative genius has never failed when the proper combinations for accomplishment are present. The gasoline engine made the limousine possible. A radio bell holds the same relation to wireless telephone development.

### Pioneer Work in Ether Waves

(Continued from page 249)

signals from Cornwall or Ireland to Newfoundland, it constituted an epoch in human history, on its physical side, and was itself an astonishing and remarkable feat. The present achievement of changing over from Morse signals to ordinary speech, made possible by the valves of Professor Fleming and Dr. Lee de Forest and others, is a natural though still surprising outcome and development of long-distance transmission, and must lead to further advances, of which at present we can probably form but a very imperfect conception.

#### EARLY EXPERIMENTS

Well now I must go back to early times. In or about the year 1875 Mr. Edison observed something, which at that time could by no means be understood, about the possibility of drawing sparks from insulated objects in the neighborhood of an electrical discharge. He did not pursue the matter,

## Radak Radio Receiving Sets made by America's Oldest and Largest Manufacturers of Radio Equipment Exclusively

Since radio was in its infancy, the Clapp-Eastham Company have been pioneers and leaders in the development of radio equipment.

When radio was still in its experimental stages, Clapp-Eastham made sets and equipment for the United States and other governments. When the broadcasting of musical programs and news made radio a popular craze, Clapp-Eastham were first to give the public receiving sets that any novice could operate—sets of utter simplicity, free from confusing devices. And furthermore, sets obtainable at a popular price.

The popularity of radio is fast spreading around the entire world. In selecting a radio set, the purchaser who is wise selects a set made by widely experienced manufacturers *who stand behind their product*. We are prepared to give prompt, satisfactory service. Write for full information about Radak Radio Sets with prices ranging from \$25.00 to \$300.00.

Send post card today to

### CLAPP-EASTHAM COMPANY

Established 1907

107 Main Street, Cambridge, Mass., U. S. A.

New York, N. Y., 395 Broadway

San Francisco, Cal., 709 Mission St.

Ridenour, Seaver & Kendig, Caxton Bldg., Cleveland, O.

# Radak

REG. U. S. PAT. OFF.

## RELIABLE RADIO SETS

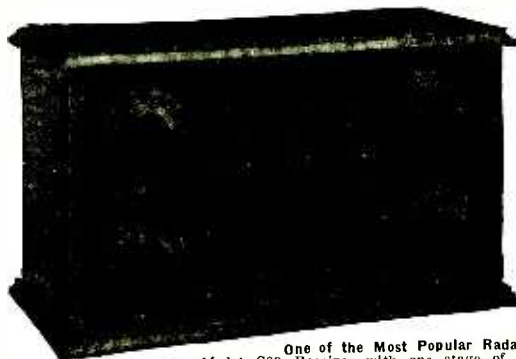

Licensed under  
Armstrong U. S.  
Pat. No.  
1,113,149.

One of the Most Popular Radak Sets  
Model C23 Receiver with one stage of radio amplification, regenerative detector and two stages of audio frequency, may be used with any type of tubes, with either dry cells or storage battery. Functions perfectly on small indoor or loop antenna. Has simple control and uses new sensitive Radak vernier dials. Wave lengths 225 to 550 meters.  
Price \$125.00

### HYGRADE SPECIALS

- 200 ft. 7 strand No. 22 Copper aerial wire... \$1.25
  - Morse Eureka Test Clips, per dozen... .50
  - Skinderviken Transmitter Buttons... .95
  - No. 763 Eveready 22½ V. Variable B. Bat... 1.25
  - No. 766 Eveready 22½ V. Variable B. Bat... 1.98
  - No. 767 Eveready 45 V. Variable B. Battery... 3.98
  - 2000 Ohm Murdock No. 56 Head Sets... 3.75
  - 3000 Ohm Murdock No. 56 Head Sets... 4.25
  - Federal or Brandes Head Sets Complete... 5.98
  - Dictograph 3000 Ohm Head Sets... 5.98
  - Fada or Framingham Rhoostats... .65
  - Acme Amplifying Transformers (new type)... 3.75
  - Acme R. F. Transformers, Types R2—R3—R4... 3.98
  - 6 Volt Marko Storage Batteries... 8.95
  - Firco (Bull Dog Grip) Phone Plugs... .75
  - Federal Amplifying Transformers... 4.75
  - 23 Plate Var. Cond. Bakelite Ends... 1.49
  - 43 Plate Var. Cond. Bakelite Ends... 1.95
- All orders must include Parcel Post charges

**Hygrade Electrical Novelty Co.,**  
41 West 125th Street New York, N. Y.

### RADIO TUBE EXCHANGE

- W. D. 11 or W. D. 12... \$3.50
  - U. V. 200 or C. 300... \$2.75
  - U. V. 201 or C. 301... \$3.00
  - U. V. 201A or C. 301A... \$3.50
- We Repair All Standard Makes of Tubes  
Including
- U. V. 199 or C. 299... \$3.50
  - U. V. 202 or C. 302... \$3.50
  - New 1½ Volt Tubes... \$4.00
- All tubes guaranteed to do the work.

**RADIO TUBE EXCHANGE**  
200 BROADWAY NEW YORK CITY, N. Y.  
All Mail Orders Given Prompt Attention  
Orders sent Parcel Post C. O. D.

WANTED—Back numbers of Radio News, Dec., 1921, Jan. and Feb., 1922. Experimenter Publishing Co., 53 Park Place, New York City.

## U.S. PATENTS

**SEND FOR THIS FORM**

### Don't Lose Your Rights

Before disclosing your invention to anyone send for blank form "Evidence of Conception" to be signed and witnessed. A sample form together with printed instructions will show you just how to work up your evidence and establish your rights before filing application for patent. As registered patent attorneys we represent hundreds of inventors all over the U. S. and Canada in the advancement of inventions. Our schedule of fees will be found reasonable. The form "Evidence of Conception" sample, instructions relating to obtaining of patent and schedule of fees sent upon request. Ask for them,—a postcard will do.

**LANCASTER & ALLWINE**

270 OURAY BLDG., WASHINGTON, D. C.

"Originators of form Evidence of Conception"

## PATENTS

**To the Man with an Idea**

I offer a comprehensive, experienced, efficient service for his prompt, legal protection and the development of his proposition. Send sketch, or model and description, for advice as to cost, search through prior United States patents, etc. Preliminary advice gladly furnished without charge. My experience and familiarity with various arts frequently enable me to accurately advise clients as to probable patentability before they go to any expense.

*Booklet of valuable information and form for properly disclosing your idea free on request.*

*Write today.*

**RICHARD B. OWEN**  
PATENT LAWYER

2 Owen Building, Washington, D. C.  
2276A Woolworth Bldg., New York City

## Starting a Company?

Save expenses and taxes by organizing on the popular, COMMON LAW plan under a pure DECLARATION OF TRUST. No experience required to fill in DEMAREE STANDARD FORMS, issue shares and begin doing business at once. Genuine DEMAREE FORMS are nationally known, approved by attorneys and utilized by successful concerns throughout the United States. Send for large, free pamphlet (D40) containing valuable information that you may need. C. S. DEMAREE, legal blank publisher, 708 Walnut, Kansas City, Missouri.

*You can be quickly cured, if you*

## STAMMER

Send 10 cents for 288-page book on Stammering and Stuttering, "Its Cause and Cure." It tells how I cured myself after stammering 20 yrs. B. N. Bogue, 890 Bogue Bldg., 1147 N. III. St., Indianapolis

## INVENTORS

who derive largest profits know and heed certain simple but vital facts before applying for Patents. Our book *Patent-Sense* gives those facts; free. Write Lacey & Lacey, 631 F St., Washington, D. C. ESTABLISHED 1869.

for the time was not ripe; but he called it "Ethereic Force," a name which rather perhaps set our teeth on edge; and none of us thought it of much importance. Silvanus Thompson, however, took the matter up in a half-hearted sort of way, and gave a demonstration to the Physical Society of London in, I believe, June, 1876, a paper which I have had a little difficulty in finding in the proceedings of that society. Nothing much came of it, however, though his argument tended to show that the sparks could be accounted for on known principles. The value of this is merely that it must have rendered Thompson susceptible to methods of detecting real electric waves, when they were discovered later.

It was found afterwards that Joseph Henry, at the Smithsonian Institution in Washington, had observed something of the same kind so early as 1842. And he seems to have had an intuition of the possible importance and far-reaching consequences of his observation. For he speaks as follows: (I quote from a passage cited in my "Modern Views of Electricity," an appended lecture "On the Discharge of a Leyden Jar.")

"It would appear that a single spark is sufficient to disturb perceptibly the electricity of space throughout at least a cube of 400,000 feet of capacity, and . . . it may be further inferred that the diffusion of motion in this case is almost comparable with that of a spark from flint and steel in the case of light."

That is to say, so early as 1842 Joseph Henry had the genius to surmise—it was only surmise, of course—that there was some similarity between the etherial disturbance caused by the discharge of a conductor and the light emitted from an ordinary high temperature source.

In the light of our modern knowledge, and Clerk Maxwell's Theory, we now know that the similarity is very near akin to identity. Both sources emit ether waves, though prodigiously differing in length.

Subsequent to these early stray observations, an amazingly suggestive observation, of a partially similar kind, was made by that singular genius and brilliant experimenter, David Hughes, the inventor of the microphone or telephone transmitter, and of the Hughes printing telegraph still used in France.

He was a man who "thought with his fingers," and who worked with the simplest home-made apparatus—made of match boxes and bits of wood and metal, stuck together with cobbler's wax and sealing wax. Such a man constantly working is sure to come across phenomena inexplicable by orthodox science. And orthodox science is usually too ready to turn up its nose at phenomena which it does not understand, and so thinks it simplest not to believe in. As a matter of fact Hughes unknowingly was very nearly on the trail of what was subsequently discovered, in a so much more enlightened manner, by Hertz. Hughes, too, got sparks in the course of his experiments, but he also got something very like coherer action too, by means of his microphone detectors.

These spasmodic observations are not exactly and strictly discoveries: they were more akin to vague intuitions. The first and gigantic step in the real discovery was made by Clerk Maxwell, in or about 1865; and he made it in mathematical form, not in experimental actuality, by one of those superhuman achievements which are only possible to our greatest mathematical physicists. He did not discover either the way to generate those ether waves, or to detect them; but he did give their laws: he legislated for them before they were born. He knew the velocity with which they must move, and gave implicitly, though without elaboration, the complete theory of their nature.

## Standard Spanish ARMY



Used by French During World War

Buy direct from sole U. S. importers and SAVE 1/2 on this GENUINE ASTRA AUTOMATIC

Your chance to have the finest European pistol—the equal of any similar American gun—at about 1/2 the price. Order direct at these special prices.

- \$7.75 25 calibre—7 shot—C. O. Q. Automatic.
- 8.95 25 calibre—7 shot—Astra Automatic.
- 9.95 25 calibre Astra with triple safety.
- 10.95 32 calibre—10 shot Astra, extra magazine.
- 16.95 32-20 and 38 cal. swing-out cyl. revolvers.

We guarantee every gun against defective workmanship; brand new; of Drop Forged Steel Throughout. Before buying any weapon INSIST on this guarantee. SEND NO MONEY unless you wish. State model desired—pay postman on delivery plus postage. Satisfaction guaranteed or money refunded. Write for new firearms catalogue.

**CALIFORNIA TRADING CO.**  
Dept. 239, Terminal Bldg., Los Angeles, Cal.

## SALESMEN

Largest radio publishing organization in the world, wants salesmen, either whole or side line, to sell an assortment of 20 books to the trade.

*Liberal commission to hustlers.*

Box 233, RADIO NEWS  
New York City.

## IT'S EASY TO BUILD THINGS

WITH A JUNIOR BENCH SAW

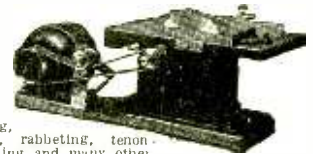

Does your ripping, grooving, rabbeting, tenoning, sanding, grinding and many other operations, with surprising ease and accuracy. Top 10"x13". Saws 1 1/2" stock. Dadoes 5/8"x5/8". Machine built entirely of metal. Driven by 1/4 or 1/2 h. p. motor. Portable. Attaches to any light socket. Extremely accurate.

Descriptive circular tells many things of interest to workers in wood and soft metals.

W. & J. BOICE, Dept. 709, Toledo, Ohio

## STAMMER

If you stammer attend no stammering school till you get my large FREE book entitled "STAMMERING, Its Origin and The Advanced Natural Method of Cure," bound in cloth and stamped in pure gold. Ask for special tuition rate and a FREE copy of "The Natural Speech Magazine." Largest, best equipped and most successful school in the world for the cure of stammering, stuttering, etc. No sing-song or time heat. Write today.

The North-Western School, 2366 Grand Ave., Milwaukee, Wis.

## BECOME A PROFESSIONAL PHOTOGRAPHER



EARNING \$35 TO \$125 A WEEK. Three to six months' course. Motion Picture, Commercial, Portraiture. Practical instruction. Modern equipment. Ask for Catalog No. 56.

N. Y. INSTITUTE of PHOTOGRAPHY  
NEW YORK CHICAGO BROOKLYN  
141 W. 38th St. 630 S. Wabash Ave. 505 State St.

## ARE YOU SELF-CONSCIOUS?

Embarrassed in company, lacking in self-control? Let me tell you how you can overcome these troubles. M. VERITAS, 1400 Broadway, New York City



Up to this time the nature of light was unknown. All the other theories of light had attempted to explain it on mechanical principles, like the vibrations of an elastic solid. Light was known to consist of transverse waves: the wave-length and the frequency of oscillation could be determined. But no one knew what was oscillating, nor what the mechanism of propagation was. With extraordinary genius Fresnel and MacCullagh had explained the phenomena of light in all detail as regards reflection, refraction, diffraction, interference, and Polarization. But the nature of the waves was unknown; and the elastic solid theory, though fascinating, was felt by those who dived most deeply into it to contain some flaw and to be, strictly speaking, unworkable. Light did not seem explicable on dynamical principles—the principles which were so fruitfully devised by Galileo and Newton for dealing with ordinary matter.

MacCullagh's theory indeed was not dynamical, and in that respect had some advantage. But it was also more vague and less definite on that account; though, being thus indefinite and yet enabling results to be achieved, it was less liable to be upset and replaced by future discovery.

(To be concluded in the next issue.)

### The Radio Gun

(Continued from page 250)

put into operation in every modern city, and the crime wave would stop. It would be cheap insurance for us to pay a fee every time we found it necessary to send in a call for help by this means; and by paying such a fee there would be many amateurs on the job at all times, ready to be the first to get the call in to headquarters and receive the reward as recompense.

Of course, the above explanation is only a suggestion, but since wired protective devices are used in most stores there is no reason why radio could not be used for the same purpose.

### Definition of Radio Terms

(Continued from page 284)

in the entire antenna circuit to the square of the effective current at the point of maximum current.

Note: Antenna Resistance includes:

- Radiation Resistance,
- Ground Resistance,
- Radio-frequency resistance of conductors in antenna circuit and equivalent resistance of conductors in the antenna circuit,
- Equivalent resistance due to corona, eddy currents, insulator leakage, dielectric loss, and so on

Anti-Resonance (See parallel resonance).

Aperiodic Circuit: An electric circuit in which a voltage impulse will produce transient current in one direction only.

Arc-Converter: An electric arc used for the conversion of direct to alternating or pulsating current. Types of current generated are classified as follows:

**Type 1.** That in which the amplitude of the alternating current produced is less than half the direct current through the arc.

**Type 2.** That in which twice the amplitude of the alternating current produced is at least equal to the direct current, but in which the direction of the current through the arc is never reversed.

**Type 3.** That in which the amplitude of the initial portion of the alternating current produced is greater than the direct current passing through

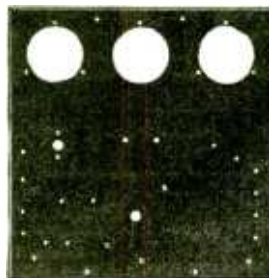

## Radio Panels that will not deteriorate with age or use

**A** MATERIAL suitable for Radio Panels that can be absolutely relied upon to retain its electrical and mechanical properties unimpaired, through wide variations in temperature, adverse atmospheric conditions and exposure to strong light.

Such is the phenol resin laminated product made and sold only by those licensed to use

### BAKELITE Condensite REDMANOL

Phenol resin laminated material is used by all large manufacturers of radio equipment and by the U. S. Army and Navy Departments. It combines to an unequalled degree all of those properties essential to satisfactory radio performance.

Its high dielectric strength is unchanging—if anything, it actually increases with age.

It is absolutely rigid, and will not warp, swell, shrink, or become brittle through exposure to moisture, heat or cold.

It will not fade to a greenish grey even though exposed to the action of strong sunlight. It will not bloom under the most humid atmospheric conditions.

It is a standardized product obtainable in a variety of dimensions and thicknesses, and its quality does not vary.

It is readily machined, drilled, punched, threaded, and etched.

Write for a copy of Booklet B describing phenol resin materials and their remarkable fitness for Radio Work.

Divisions of  
**BAKELITE CORPORATION**

**BAKELITE**  
General Bakelite Co.  
8 West 40th St. New York

**Condensite**  
Condensite Co. of America  
Bloomfield, N. J.

**REDMANOL**  
Redmanol Chemical  
Products Co.  
636-678 West 22nd St.  
Chicago, Ill.

### BAKELITE CORPORATION

Address the Divisions

## The Material of a Thousand Uses

**Super-Sensitiveness!**

**THE** crystal is the "bull's-eye" of your crystal receiving set. Unless it is super-sensitive you are wasting time and entertainment and cannot "hit" the combination for best results. Insist upon the genuine original Arlington Tested NAA Detector Minerals. They are carefully selected from bulk stock, individually tested and guaranteed super-sensitive.

Galena, Silicon or Goldite price per crystal, 25c. Same mounted in brass cup, 40c. Obtainable at your dealer's or sent direct (post-paid) on receipt of price.

**The Newman-Stern Co.**  
Newman-Stern Building Cleveland

10c



**Jones' "FIDDLESTICK" Vernier**

Drill one hole on side of each dial and make all fine adjustments with your hand away from set. Nicely finished in black enamel. Mounted 24 on a card for counter display. Sample mailed for 12c stamps. Ready for immediate delivery.

**Howard B. Jones**  
612 S. Canal St. Chicago, Ill.

Insure your copy reaching you each month. Subscribe to Radio News—\$2.50 a year. Experimenter Publishing Co., 53 Park Place, N. Y. C.

THESE DEALERS CARRY

# "Consolidated" E.I. Company

## Patterns and 25c. Books

See Full Page Ads on Pages 303 and 326

- |   |   |   |  |  |   |
|---|---|---|--|--|---|
| <p><b>Ahilete, Kans.</b><br/>United Elec. Co.</p> <p><b>Albany, Ga.</b><br/>Lonsbergs Book House</p> <p><b>Akron, O.</b><br/>Radioart Supply Co.</p> <p><b>Albany, N. Y.</b><br/>Havens Elec. Co.<br/>Lecton Service Supply Co<br/>Comper &amp; Hochkiss<br/>Kimball Bros<br/>Peoples Radio Store<br/>Standard Elec. Co.<br/>Wanger Bros.</p> <p><b>Amsterdam, N. Y.</b><br/>Anderson Elec. Co.</p> <p><b>Allentown, Pa.</b><br/>Hess Bros.<br/>Buchman Book Store<br/><b>Altoona, Pa.</b><br/>Altoona Elec. Supply Co.</p> <p><b>Anthony, Kans.</b><br/>LeRoy Highbanks Rad. Co.</p> <p><b>Astoria, Ore.</b><br/>Astoria Radio Shop</p> <p><b>Atchison, Kans.</b><br/>Low &amp; Blythe Co.</p> <p><b>Atlanta, Ga.</b><br/>Capital Elec. Co.<br/>Millers Book Store</p> <p><b>Atlantic City, N. J.</b><br/>Paramount Radio Co.<br/>Eastern Hdwe. &amp; Sup. Co.<br/>Sport Shop<br/>Just Elec. Co.<br/>Sea Coast Radio Co.</p> <p><b>Auburn, Me.</b><br/>G. L. Fass</p> <p><b>Baltimore, Md.</b><br/>Jos. A. Becker<br/>Jos. M. Zamoski<br/>Wilbur Elec. Co.<br/>Baharach Razin Co.<br/>W. W. Hentzschel<br/>S. B. Berkovich<br/>Joel Gutman<br/>Herdas Elec. Co.<br/>Little Joes Dept. Store<br/>C. D. Kellert<br/>J. Meyer<br/>Mundock Co.<br/>E. I. Rosenfeld &amp; Co.</p> <p><b>Batavia, N. Y.</b><br/>H. F. Smith</p> <p><b>Bethlehem, Pa.</b><br/>Leitch Radio Co.</p> <p><b>Billings, Mont.</b><br/>Tomerson Bros.</p> <p><b>Birmingham, Ala.</b><br/>Interstate Elec. Co.</p> <p><b>Bluefield, W. Va.</b><br/>Burgess Elec. Co.</p> <p><b>Boston, Mass.</b><br/>Atlantic Radio Co.<br/>Cutter &amp; Wood Supply Co.<br/>Seth Fuller Co.<br/>International Radio Corp.<br/>Lewis Elec. Supply<br/>P. D. Pitts Co.<br/>Williams Book Stores<br/>J. B. Hunter &amp; Co.<br/>James H. Jones, Inc.<br/>Samuel J. Beckwith<br/>Chandler &amp; Parobuar Co.<br/>A. P. Merchant Co.<br/>Eugene Proctor Co., Inc.<br/>Radio Sales &amp; Service Co.<br/>Parrington &amp; Clark<br/>Bermao Radio</p> <p><b>Bridgeport, Conn.</b><br/>Morison Radio-Phone Parts<br/>Flynn &amp; Power<br/>Conn. Radio Supply Co.</p> <p><b>Brooklyn, N. Y.</b><br/>Bklyn. Radio Serv. Co.<br/>O. Olsen<br/>Tolner Elec. Co.<br/>Bklyn. Radio Center<br/>Bobs Radio Service<br/>Bklyn. Elec. Lamp &amp; Nov.<br/>Globe Radio &amp; Bat. Shop<br/>Hagg &amp; Vines Co.<br/>G. Kleinfelch<br/>C. G. Rosewall<br/>J. Streiff<br/>Denmarks<br/>American Phon. Exch.<br/>Arlington Radio Service<br/>Barneys Radio Shop<br/>Benzo Elec. Co.<br/>J. D. Cunningham<br/>Delta Elec. Co.<br/>H. A. Dietz<br/>Duckmans Music Store<br/>Kelley &amp; Peist<br/>Jainem Elec. Co.<br/>Kensington Radio<br/>E. C. &amp; H. B. Laseholm<br/>G. Moskowitz<br/>G. Scharff Sons</p> | <p>H. Schur &amp; Son<br/>Victor Radio Sport Shop<br/>Walker Elec. Co.<br/>Breuer Bros.<br/>20th Century Radio Co.<br/>M. Ulrich<br/>B. Haupt<br/>David M. Isaac<br/>Starr Radio<br/>Buffalo, N. Y.<br/>McCarthy Bros. &amp; Ford<br/>Robertson Cataract<br/>O. Ulbrich Co.</p> <p><b>Burlington, N. J.</b><br/>Burlington Elec. Co.</p> <p><b>Butte, Montana</b><br/>Montana Elec. Co.</p> <p><b>Cambridge, Mass.</b><br/>Chapp-Easthail Co.<br/>University Book Store<br/>Canton, Ill.<br/>Frank White &amp; Bros.<br/>Camden, N. J.<br/>Neisner Bros.</p> <p><b>Carrollton, Mo.</b><br/>Carrollton Radio Shop</p> <p><b>Centerville, Va.</b><br/>H. E. Luther</p> <p><b>Champaign, Ill.</b><br/>H. C. Swannell &amp; Son</p> <p><b>Charlestown, W. Va.</b><br/>John R. Koch</p> <p><b>Charleston, S. Car.</b><br/>S. C. Radio Shop</p> <p><b>Charlotte, N. C.</b><br/>Smith Novotny Elec. Co.<br/>Caroline Radio Co.</p> <p><b>Chester, Pa.</b><br/>Neisner Bros.</p> <p><b>Chicago, Ill.</b><br/>Harry Aizer &amp; Co.<br/>Barawk Co.<br/>Beckley-Ralston Co.<br/>Chicago Radio App. Co.<br/>Elec. Appliance Co.<br/>Inland Elec. Co.<br/>Marshall Field &amp; Co.<br/>A. C. McClung &amp; Co.<br/>Montgomery Ward &amp; Co.<br/>Newark Elec. Co.<br/>Henry Paulson &amp; Co.<br/>Sears-Roebuck &amp; Co.<br/>Chicago Cut Rate Book<br/>Community Book Store<br/>Izenstark Radio Co.<br/>Follett Book Co.<br/>McArthur Elec. Co.<br/>P. O. News Co.<br/>Max Stein<br/>F. J. Stringus</p> <p><b>Fireide Radio Co.</b><br/><b>Cincinnati, O.</b><br/>Midwest Radio Co.<br/>Miller Elec. Co.<br/>Reuter Elec. Co.</p> <p><b>Cleveland, O.</b><br/>Radio Electric Shop<br/>Radio Eng. &amp; Sales Co.<br/>H. Lesser &amp; Co.<br/>Oliver C. Schroeder<br/>Radio Sales &amp; Rep. Co.<br/>Columbus, O.<br/>Hall Elec. Co.</p> <p><b>Coraopolis, Pa.</b><br/>T. J. Donovan</p> <p><b>Cumberland, Md.</b><br/>J. A. Fulton &amp; Co.</p> <p><b>Dallas, Texas</b><br/>Huey &amp; Philip Hdwe. Co.<br/>Southwest Radio Sup. Co.<br/>Radio Equip. Co.</p> <p><b>Denton, Tex.</b><br/>Evers Hdwe. Co.</p> <p><b>Denver, Colo.</b><br/>Electrical Auto App. Co.<br/>F Pratt Book Store<br/>Reynolds Radio Co.</p> <p><b>Des Moines, Ia.</b><br/>H. W. King</p> <p><b>Iowa Radio Co.</b><br/><b>Detroit, Mich.</b><br/>Federal Elec. Supply Co.<br/>Twentieth Century Radio Co.<br/>Crowley Milner Co.<br/>McAuley Bros.<br/>Detroit Elec. Co.<br/>Wolverine Radio Co.<br/>Northwestern Radio Co.<br/><b>Duluth, Minn.</b><br/>Kelley Duluth Co.</p> <p><b>Easton, Pa.</b><br/>F. &amp; W. Grand Stores<br/>E. Orange, N. J.<br/>Easton Radio Shop<br/>United Radio &amp; Sport Shop<br/>Elizabeth, N. J.<br/>H. Richmond &amp; Son<br/>Elizabeth Elec. Sup. Co.</p> | <p><b>Eureka, Ill.</b><br/>Klaus Radio Co.</p> <p><b>Fergus Falls, Minn.</b><br/>Grande Setzer</p> <p><b>Far Rockaway, L. I.</b><br/>Dunlap Spte. Goods Co.</p> <p><b>Scientific Radio Co., Inc.</b><br/>Flushing L. I.<br/>The Electric Shop</p> <p><b>Ft. Worth, Tex.</b><br/>H. C. Meacham Co.</p> <p><b>Galveston, Tex.</b><br/>Galveston Wireless Sup. Co.</p> <p><b>Gardner, Mass.</b><br/>Gardner Hdwe. Co.</p> <p><b>Gloucester, N. J.</b><br/>Lenny's Variety Store</p> <p><b>Granite City, Ill.</b><br/>Trosenberg Dept. Store</p> <p><b>Great Bend, Kans.</b><br/>Great Bend Radio Co.</p> <p><b>Greensburg, Pa.</b><br/>H. Hamilton</p> <p><b>Hamilton, O.</b><br/>Radio Co.</p> <p><b>Hartford, Conn.</b><br/>Elec. Sup. &amp; Equip. Co.<br/>F. &amp; W. Grand Stores<br/>G. Fox &amp; Co.</p> <p><b>Havana, Cuba</b><br/>Diamond News Co.<br/>Liberia de Jose Aibele</p> <p><b>Helena, Mont.</b><br/>Van Parison Co.</p> <p><b>Hoboken, N. J.</b><br/>International Book Store<br/>Eagans Radio</p> <p><b>Holyoke, Mass.</b><br/>Haskell Elec. Co.</p> <p><b>Independence, Mo.</b><br/>The Melodion Co.</p> <p><b>Hackensack, N. J.</b><br/>Wurtz &amp; Fuchs</p> <p><b>Jacksonville, Fla.</b><br/>Southern Elec. Co.<br/>Holt Elec. Co.</p> <p><b>Jamestown, N. Y.</b><br/>Willis Switich &amp; Inst. Co.</p> <p><b>Jamaica Plain, Mass.</b><br/>Conrad Radio Co.</p> <p><b>Jamaica, L. I.</b><br/>Scientific Radio Co., Inc.</p> <p><b>Merrick Elec. Co.</b><br/><b>Jersey City, N. J.</b><br/>Armstrong Elec. Co.<br/>M. Schlein<br/>Guarantee Elec. Co.</p> <p><b>Johnson City, Tenn.</b><br/>Bishop Elec. Co.</p> <p><b>Johnstown, Pa.</b><br/>W. T. Grant Co.</p> <p><b>Joliet, Ill.</b><br/>Joliet Book &amp; Sta. Co.</p> <p><b>Kansas City, Mo.</b><br/>Vulcanizers Supply Co.<br/>Donaldson Radio Co.</p> <p><b>Lancaster, Pa.</b><br/>Radio Outfit &amp; Sup. Co.</p> <p><b>Lawrence, Mass.</b><br/>Schwarzenberg Bros.</p> <p><b>Los Angeles, Cal.</b><br/>Leo J. Meyberg<br/>S. California Elec. Co.</p> <p><b>West Radio Elec. Co.</b><br/>Natick Book Store<br/>Brode Elec. Co.</p> <p><b>Lewiston, Montana</b><br/>Chas. Williams</p> <p><b>Lock Haven, Pa.</b><br/>Burkett Bros.</p> <p><b>Louisville, Ky.</b><br/>Sutcliffe Co.</p> <p><b>Lowell, Mass.</b><br/>G. A. Hill Co.</p> <p><b>Lyons, Kans.</b><br/>R. I. Case</p> <p><b>Macon, Ga.</b><br/>J. W. Burke Co.</p> <p><b>Memphis, Tenn.</b><br/>Street Elec. Co.</p> <p><b>Mckeesport, Pa.</b><br/>F. C. Wampler &amp; Son</p> <p><b>Milwaukee, Wis.</b><br/>Julius Andrae &amp; Co.<br/>Dewey Sport Goods Co.<br/>Badger Radio Co.</p> <p><b>Minneapolis, Minn.</b><br/>Jacob Andraess Co.</p> <p><b>Findley Elec. Sup. Co.</b><br/>Nagell Hdwe. Co.<br/>Reinhard Bros. Co., Inc.<br/>Sterling Elec. Co.</p> <p><b>Peoples Elec. Co.</b><br/><b>Missoula, Mont.</b><br/>Missoula Elec. Sup. Co.</p> <p><b>Montgomery, Ala.</b><br/>Alabama Radio Mfg. Co.<br/>R. P. Reeves</p> | <p><b>Nashville, Tenn.</b><br/>Zihart Bros.</p> <p><b>Newark, N. J.</b><br/>Bambarger &amp; Co.<br/>Bassett Radio Sup. Co.<br/>Davis Elec. Co.<br/>Eddies Wireless Ex.<br/>Baumister &amp; Pollard<br/>Essex Mfg. Co.<br/>W. T. Grand Co.<br/>United Elec. Sup. Co.<br/>Friedmanns Music Shop</p> <p><b>Mt. Vernon, N. Y.</b><br/>Stephens Shop</p> <p><b>New Brunswick, N. J.</b><br/>Schneider Bros.<br/>The Elec. Shop</p> <p><b>New Orleans, La.</b><br/>Interstate Elec. Co.</p> <p><b>Newport, R. I.</b><br/>Geo. H. Chase</p> <p><b>New Haven, Conn.</b><br/>W. W. Gale &amp; Co.</p> <p><b>New York City</b><br/>Femo &amp; Co.<br/>Frank Radio Co.<br/>Fremont Radio Co.<br/>J. I. Kelleher<br/>David Killoch &amp; Co.<br/>Liberty Radio Co.<br/>R. H. Macy &amp; Co.<br/>Manhattan Elec. Sup.<br/>Overland Radio &amp; Equip. Co.<br/>Peerless Light Co.<br/>Radio Specialty Co.<br/>Stanley &amp; Patterson<br/>Viking Radio Co.<br/>The Winchester Store<br/>Army &amp; Navy Dist. Co.<br/>Chamberlain Elec. Co.<br/>Economy Radio<br/>Elec. Service Eng. Co.<br/>Goldinger Bros.<br/>Gimbel Bros.<br/>R. G. Haslinger<br/>Herbert &amp; Huesien<br/>Allied Radio Co.<br/>J. Helmut<br/>J. H. Bunnell &amp; Co.<br/>Butler Bros.<br/>Carnahan &amp; Dalzell, Inc.<br/>Bway Radio Corp.<br/>P. M. Dreyfuss Co., Inc.<br/>Delta Elec. Co.<br/>Fordham Radio Spee. Co.<br/>F. &amp; W. Grand Stores<br/>J. L. Lewis &amp; Co.<br/>Lowe Motor Sup. Co.<br/>Rora Radio Stores<br/>Live Wire Elec. Co.<br/>Marks Radio<br/>Modelis—S. Stores<br/>Phillips Sport Shop<br/>Wehman Bros.<br/>A. &amp; A. Elec. Co.<br/>Acme Radio Co.<br/>Am. Elec. Tech. App.<br/>Atlas Elec. Supply Co.<br/>Atlas Radio Co.<br/>Bergmeyer Bros.<br/>Franklin Radio Shop<br/>J. Gabler<br/>Globe Radio Shop<br/>Hygrade Elec. Co.<br/>International Radio Store<br/>J. Kelleher<br/>Marlen Hdwe. Co.<br/>Nassau Radio Co.<br/>Times Sq. Auto Sup. Co.<br/>Triggers<br/>Ace Elec. Co.<br/>A. &amp; P. Radio Co.<br/>Baker &amp; Taylor Co.<br/>Borough Elec. Co.<br/>Columbia Elec. Co.<br/>J. Knelson<br/>Keystone Battery Service<br/>S. S. Kresse &amp; Co.<br/>Langers Radio Store<br/>A. Marcus<br/>G. H. Masten &amp; Co.<br/>Mentz Store<br/>Milbro Radio &amp; Elec. Co.<br/>Radio &amp; Mech. Trad. Corp.<br/>Radio Parlor<br/>Radiophone Equip. Co.<br/>New Eng. Elec. Spee. Co.<br/>Rialto Elec. Shop<br/>St. Marks Radio Co.<br/>K. R. Schullstrom<br/>F. E. Silberman<br/>Voelker<br/>W. Workman<br/>Perfection Radio<br/>Cornland Radio<br/>James Gear<br/>A. J. Goldman</p> | <p><b>T. Eaton &amp; Co.</b><br/>Cross Radio Co.<br/>Progressive Book Store<br/>S. Astor<br/>M. &amp; T. Elec. Co.<br/>Houghton Elec. Co.<br/>Marvel Elec. Sup. Co.<br/>O. R. K.<br/>A. E. Zimmerman<br/>Sam Astor<br/>Davidson Radio Co.<br/>Van Auto Supply Co.<br/>Mogul Elec. Co.<br/>Hruswick Supply Co.<br/>Stuyvesant Radio Co.<br/>Oscars Radio<br/>Fordham Sup. Co.<br/>Int. News Co.<br/>M. H. Elec. Co.<br/>The Heights Radio Sup. Co.<br/>Eclipse Elec. Co.<br/>Fordham Radio Co.<br/>Crescent Radio Co.<br/>Terminal Rad. &amp; Mus. Shop<br/>United Anchor Tire Co.<br/>Inter City Radio Co.<br/>Josephson<br/>Redifon Corp.<br/>Greenwich Radio Co.<br/>H. Goldstein<br/>Isador Pajans, Inc.<br/>Grand Radio<br/>M. Rubin<br/>Hannes &amp; Co.<br/>Madison Hdwe. Store<br/>American Radio Co.<br/>American Elec. Tecl. Co.<br/>Electrical Eng. &amp; Con. Co.</p> <p><b>Niagara Falls, N. Y.</b><br/>H. Messersmith &amp; Sons</p> <p><b>Norristown, Pa.</b><br/>E. M. Law<br/>Oakland, Cal.<br/>Warner Bros.<br/>E. M. Sargent Co.</p> <p><b>Omaha, Nebr.</b><br/>Wolfe Elec. Co.</p> <p><b>Onset, Mass.</b><br/>W. C. Spring</p> <p><b>Passaic, N. J.</b><br/>Simon Bros.<br/>Passaic Radio Shop</p> <p><b>Perth Amboy, N. J.</b><br/>Smelling, J.<br/>Amboy Lighting Co.<br/>Amboy Radio</p> <p><b>Paterson, N. J.</b><br/>Federal Radio &amp; Elec. Co.</p> <p><b>Pawtucket, R. I.</b><br/>DeLaney Feltch &amp; Co.</p> <p><b>Peoria, Ill.</b><br/>People's News Stand</p> <p><b>Philadelphia, Pa.</b><br/>Gimbel Bros.<br/>H. C. Roberts El. Sup. Co.<br/>Sayre Level Radio Co.<br/>Goetz Music Stores<br/>F. &amp; W. Grand Stores<br/>E. P. Noll &amp; Co.<br/>G. W. Small Co.<br/>Neisner Bros.<br/>Schimmel Elec. Co.<br/>Radio Sales Co.<br/>John Wanamaker</p> <p><b>Phoenix, Ariz.</b><br/>Nielsen Radio Sup. Co.</p> <p><b>Poughkeepsie, N. Y.</b><br/>C. Raymond</p> <p><b>Pittsburgh, Pa.</b><br/>Goldsmith &amp; Son Co.<br/>Ludwig Hommel &amp; Co.<br/>Gain-a-Day Elec. Co.<br/>Liberty Incan. Sup. Co.<br/>Pitts Radio &amp; App. Co.<br/>U. S. Radio Co. of Pa.<br/>Doubleday Hill Co.</p> <p><b>Pittsfield, Mass.</b><br/>W. T. Grant Co.</p> <p><b>Plainfield, N. J.</b><br/>H. E. Gayle Hdwe. Co.</p> <p><b>Plattsburgh, N. Y.</b><br/>H. E. Atwater</p> <p><b>Portland, Me.</b><br/>Chisholm Bros.</p> <p><b>Portland, Ore.</b><br/>E. L. Knight Co.<br/>Hyson Elec. Co.<br/>Hylands Old Book Store</p> <p><b>Pottsville, Pa.</b><br/>Potters Radio Sup. Co.</p> <p><b>Princeton, N. J.</b><br/>Princeton Cycle Shop</p> <p><b>Providence, R. I.</b><br/>R. &amp; H. Supply Co.<br/>The Shepard Co.</p> | <p><b>R. J. Elec. Equip.</b><br/>The Outlet Co.<br/>Boston Store<br/>Reading, Pa.<br/>F. &amp; W. Grand Stores</p> <p><b>Rochester, N. Y.</b><br/>Hickson Elec. Co.<br/>Rochester Elec. Sup. Co.<br/>Wheeler Green El. Sup. Co.<br/>Eastman Radio Co.<br/>R. Schmidt &amp; Co.<br/>F. C. Sykes &amp; Co.<br/>Neisner Bros.<br/>Miller Drug &amp; Elec. Co.</p> <p><b>Ridgewood, L. I.</b><br/>Ridgewood Radio Shop</p> <p><b>Rock Island, Ill.</b><br/>H. E. Gelbart &amp; Co.<br/>Readeley Specialty Co.<br/>Vaile Co.</p> <p><b>St. Joseph, Mo.</b><br/>Empire Elec. Co.<br/>Manschrecks Book Stores</p> <p><b>St. Louis, Mo.</b><br/>The Herwood Co.<br/>Linze Elec. Supply Co.<br/>Foster Book &amp; Cigar Co.</p> <p><b>St. Paul, Minn.</b><br/>North-West Elec. Eq. Co.<br/>Premier Radio Mfg. Co.<br/>Pioneer Elec. Co.<br/>St. Paul Book &amp; Sta. Co.<br/>First Book Shop</p> <p><b>San Francisco, Cal.</b><br/>Richter's Contad</p> <p><b>Schenectady, N. Y.</b><br/>Albany St. Radio Store</p> <p><b>Seattle, Wash.</b><br/>F. B. Wilson</p> <p><b>Stamford, Conn.</b><br/>Arthura</p> <p><b>Stillwater, Okla.</b><br/>Stillwater Elec. Shop</p> <p><b>Syracuse, N. Y.</b><br/>Grant's Alexander Sons<br/>Hughes Radio Corp.<br/>M. H. Salmon Elec. Co.</p> <p><b>Toledo, O.</b><br/>Kaempfer Radio Co.<br/>W. J. Nagel Elec. Co.</p> <p><b>Trenton, N. J.</b><br/>Flecken &amp; Son, Inc.<br/>Radio Chain Stores</p> <p><b>Troy, N. Y.</b><br/>L. H. Cooper &amp; Son</p> <p><b>Tyler, Tex.</b><br/>R. E. Bryan</p> <p><b>Union Hill, N. J.</b><br/>N. W. Friedman</p> <p><b>Uniontown, Pa.</b><br/>Frederick Piano Co., W. F.</p> <p><b>Utica, N. Y.</b><br/>Dent Co., M. F.<br/>Olds Book Store<br/>Utica Elec. App. Co.<br/>Utica Elec. Sup. Co., Inc.</p> <p><b>Waco, Tex.</b><br/>Jackson's Radio Eng. Lab.</p> <p><b>Washington, D. C.</b><br/>Continental Elec. &amp; Sup. Co.<br/>Radio Auto Sup. Co.</p> <p><b>Watertown, Wis.</b><br/>D. &amp; F. Kusel Co.</p> <p><b>Watertown, N. Y.</b><br/>F. A. Empsall &amp; Co.</p> <p><b>W. Hoboken, N. J.</b><br/>The Heraco Exchange</p> <p><b>W. New York, N. Y.</b><br/>W. N. Heraco</p> <p><b>Wheeling, W. Va.</b><br/>Gee Electric Co.</p> <p><b>Wapakoneta, Ohio</b><br/>Helme &amp; Narel Elec. Co.</p> <p><b>Waupaca, Wis.</b><br/>Waupaca Radio Sales Co.</p> <p><b>Wausau, Wis.</b><br/>Janke, Kurth Co.</p> <p><b>Wilkes-Barre, Pa.</b><br/>Foster Radio &amp; Elec. Co.</p> <p><b>Wilmington, Del.</b><br/>L. P. Moore<br/>Wilmington Elec. Spee. Co.</p> <p><b>Worcester, Mass.</b><br/>Newer Bros.</p> <p><b>Williamsport, Pa.</b><br/>Wilhelm Book Store<br/>Yonkers, N. Y.<br/>Knepper, F.<br/>Westchester Elec. En. Co.<br/>York, Nebr.<br/>Bullocks<br/>Youngstown, Ohio<br/>Robert F. Phillips</p> |
|---|---|---|--|--|---|



Order direct from these dealers. If your dealer cannot supply you, send us his name and address

## 233 Fulton Street, New York City

Publishers of Consolidated Patterns  
Sales Agents for E. I. Co. Books

the arc, and in which the direction of the current through the arc is periodically reversed.

**Atmospherics:** See Strays.

**Atmospheric Absorption:** The portion of the total reduction of radiated power due to atmospheric conductivity, reflection, and refraction.

**Attenuation: (Radio)**—The decrease, with distance from the radiation source, of the amplitude of the electric and magnetic components constituting an electro-magnetic wave.

**Audibility: (Radio telegraph)**—A measure of the ratio of the telephone current producing a signal in a telephone receiver to that producing a barely audible signal. (A barely audible signal is one which permits the differentiation of the dot and dash elements of the letters.)

In the simple shunted telephone method of measuring signals the audibility is defined as

$$\frac{s+t}{s}$$

where *s* and *t* are the impedances of shunt and telephone, respectively.

**Audio Frequencies:** The frequencies corresponding to normally audible sound waves. These lie below about 10,000 cycles per second.

**Autodyne Reception:** See self-heterodyne reception.

**Average Selectivity:** The average selectivity of a receiving system is the *n*th root of the product of the *n* concomitant selectivities of the system.

**Band of Wave Lengths:** A continuous range of wave-lengths extending between two definite wave-lengths.

**Beat Frequency:** The frequency of recurrence of either maxima of addition or minima of opposition of two superposed periodic phenomena of the same kind but different frequencies.

**Broadcast (Radiophone):** Organized one-way transmission of music, news items, or other matter of popular interest or entertainment.

**Buzzer Modulation:** The process of varying the output power of a continuous-wave generator at the tonal frequency of a buzzer, either by: (a) using the buzzer as a chopper or audio-frequency interrupter in the output circuit of the generator, or a circuit suitably coupled thereto, or (b) using the buzzer element in a circuit of the continuous-wave generator which permits the ready control of the output power of the generator (e. g., the grid circuit of a three-electrode tube oscillator).

**By-Pass Condenser:** A condenser used to provide a path for alternating-current around some circuit element through which current of this frequency cannot readily pass.

**Cage Antenna:** An antenna having conductors which consist of groups of parallel wires arranged as the elements of a cylinder.

**Capacitive Coupling:** The association of one circuit with another by means of capacity common or mutual to both.

**Central Station (Radio):** A combined multiplex transmitting station and/or a multiplex receiving station simultaneously operating several radio channels.

**Coil Antenna:** An antenna consisting of one or more complete turns of wire.

**Condenser Antenna:** An antenna consisting of two capacity areas.

**Continuous Waves:** Continuous waves (C W) are a succession of waves of constant amplitude and frequency.

**Continuous Waves, Interrupted (I C W):** See Interrupted Waves.

**Continuous Waves, Key Modulated:** Continuous waves of which the amplitude or frequency is varied by the operation of a transmitting key.

# The Receiver famous thru Performance Telmaco



Type B-R Receiver

fully meets the requirements of the discriminating purchaser because of the following features:

**EFFICIENCY OF OPERATION:** Securing volume, distance (1500 miles with single tube is not unusual), selectivity: broadcasting stations one-half mile distant are tuned out by a slight turn of condenser dial.

**EASE OF OPERATION** enabling the novice to secure satisfactory results.

**HIGHEST QUALITY OF WORKMANSHIP AND MATERIALS.**

**\$25.00** PRICE within the reach of everybody. Manufactured exclusively for us by

Tri-City Radio Electric Supply Co., licensed under Armstrong U. S. Patent No. 1113149, Oct. 6, 1914.

Telmaco BA 2-Stage Amplifier for the Above \$20.00

## Our New Radio Guide Book Sent at Your Request

Our new 64-page Catalog No. TCR contains twenty of the most popular radio circuits printed in blue. These include the Hazeltine Neutrodyne, Grimes Inverted, Colpits, Flewelling, Reinartz, Diode Electrad, Heterodyne, Super-Regenerative and many others. Each article used in circuit is attractively pictured instead of appearing in straight schematic form. Besides containing blue prints, the best in radio is also illustrated and described. Catalog sent postpaid for ten cents. Each circuit worth double."

Send for your copy today



20 Circuits in Blue in Catalog

**JOBBERS** We have an attractive proposition for a few more bona-fide Jobbers **DEALERS** If your Jobber cannot supply you order direct

Radio Division

**TELEPHONE MAINTENANCE CO.**

Quality Radio Exclusively

20 So. Wells St., Dept. B, Chicago, Ill.

## Every Radio Fan Should Have



### HOW TO MAKE WIRELESS RECEIVING APPARATUS

The 20 radio constructors who wrote the book know how articles should be made from simple materials. Only modern apparatus is described, such as Receiving set without aerial or ground, magnetic detector, wireless relay, wireless lecture set, etc., etc. Book has 100 illustrations, many full pages, paper bound, in two colors. Price 35 cents. Postpaid.

### HOW TO MAKE WIRELESS SENDING APPARATUS

Contains information on how to make 30 different pieces of wireless sending apparatus from materials, easily obtained. Tells how to Make an Experimental Arc Set, Speaking Arc, Quenched Gap, 1/4 K. W. Transformer, Oscillation Transformer, Photo Phone, etc., etc. Book has 100 pages (size, 7x5 in.), 88 illustrations, paper cover, printed in two colors. Price 35 cents, postpaid.



Dealers Write for Wholesale Discounts.

**Experimenter Publishing Co.**  
53 Park Place, New York City

## Illinois Cushion-Resilient

Live Rubber Cushion Base

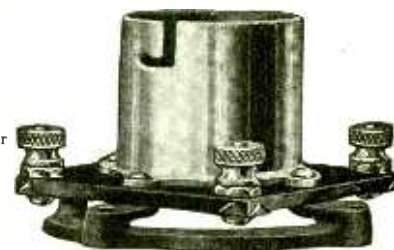

Patents Pending

This final improvement in Vacuum Tube Sockets is to protect Tubes from mechanical vibrations and shocks, which cause distortions and many of the noises in phones, especially when amplified. Furthermore, a sudden jar or shock has caused the parting of many an incandescent filament.

Complete as illustrated with cushion and high grade socket that "floats on rubber."

Model A for Standard Base Tubes, \$1.25; Model B for Small Base Tubes UV-199, \$1.00 postpaid.

Jobbers and Dealers write for proposition.

**Illinois Radio Co.**  
Springfield Illinois

PRICE



Recommended and sold by dealers in high quality radio supplies.

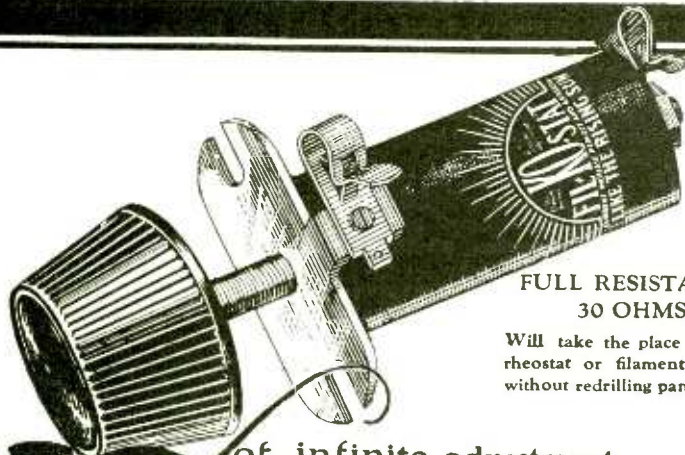

FULL RESISTANCE  
30 OHMS

Will take the place of other rheostat or filament control without redrilling panel.

The filament kontrol of infinite adjustment

# FIL-KO-STAT

enables you to hear stations you have never heard before and gives absolutely noiseless operation

## Missing What You Get

Your set is probably bringing in D X stations you never heard because your rheostat cannot control your filament action. The Filkostat gives infinite adjustment and enables you to magnify the weak stations and bring them in strong and clear.

Paul H. Woodruff, Editor Industrial Power, Chicago, writes that after installing the Filkostat he picked up KHJ and KWH, 2000 miles on a single tube regenerative detector.

## Eighteen Times More

Laboratory research proves FIL-KO-STAT to have a fine adjustment area (i.e. ability to control filament heat and electronic flow) eighteen times greater than that of the wire rheostat and several times that of the next best filament control.

FIL-KO-STAT cylindrical design is the outcome of extensive experimentation. It gives the resistance element sufficient radiating surface to eliminate excessive heating. This is one of the outstanding FIL-KO-STAT features.

## Adjusted For All Tubes

You have no screws to tamper with on the Filkostat. No adjustments to puzzle you. Experts have taken care of this for you. The Filkostat is not just fabricated. It is a laboratory product triple tested before being sent out and scientifically adjusted to the ideal "off" position for **UV200, 201, 201A, WD11, WD12, UV199, DV6A, W. E. Peanut, and all other tubes.**

## No Wires—No Discs

The makers of the FIL-KO-STAT express their confidence with an unconditional guarantee. Filkostat is assembled by precision craftsmen. It contains a resistance element so finely divided that further resistance is impossible. *There is nothing to break or chip.* When you buy a FIL-KO-STAT you know that you are not only getting the finest filament control made but that, its reliability and durability are fully and completely—

## Professional Testimony

The RADIO GUILD writes "comparisons with every reliable filament and current controlling device now available proved Filkostat far superior to all other types of filament controls giving the closest possible adjustment of any type of filament tube and the only instrument which could be used for all tubes giving equal critical adjustment at the high resistance as at the low resistance."

## Amateur Enthusiasm

Out of hundreds of testimonials, we quote—

W. R. Hagedorn, Hay Springs, Neb. — "tried 4 different Rheostats. Filkostat beats them all."

W. R. Williams, Woodsfield, Ohio "Filkostat on a single circuit regenerative giving excellent satisfaction. The noiseless operation means a great deal."

S. George Kerngood, President of Bluebird Hats, New York "only since using it I realized how wonderful a set can be made."

## Dealers' Delight

Dealers everywhere are delighted with Filkostat. Its noiseless operation has increased the joy of Radio and the "fans" are recommending it. Here's one of many interesting dealer letters.

E. M. Pace, Vicksburg, Miss. writes — "Send carton of Filkostat as early as possible. Sold sample Filkostat 5 minutes after it was received. It is proclaimed by the fan that bought it as being 100% better than the best."

## A Booklet You Will Want

By Walter C. Garvey, of Evening World's Radio Section, Editorial Staff, Handbook of Helpful Hints for Radio Set Builders, includes tables charts, legends, statistics and 16 carefully selected hookups with diagrams and full descriptions. Reading this interesting book we discovered Mr. Garvey recommended the FIL-KO-STAT. We bought an edition of the books and will gladly send a copy anywhere at handling cost 10c. postpaid.

GUARANTEED BY THE MAKER!

**DX INSTRUMENT CO.**  
HARRISBURG PA.

**RADIO STORES CORPORATION**

Sole International Distributors  
Dept. RN9 . . . 218-222 West 34th Street, New York

**Continuous Waves, Modulated at Audio Frequency:**

Continuous waves of which the amplitude or frequency is varied in a periodic manner at an audible frequency.

**Counterpoise:** A system of wires or other conductors (not the ground) forming the lower plate of a condenser antenna.

**Coupler:** An apparatus which is used to transfer radio-frequency power from one circuit to another by associating together portions of these circuits. Couplers are of the same types as the types of coupling—inductive, capacitive, and resistive.

**Coupling Coefficient:** The ratio of the mutual or common impedance component of two circuits to the square root of the product of the total impedance components of the same kind of the two circuits. (Impedance components consist of resistance, capacity, or reactance.)

**Coupling, Capacitive:** See Capacitive Coupling.

**Decremeter:** An instrument for measuring the logarithmic decrement of a circuit or of a train of logarithmically damped radio waves.

**Detection Coefficient:** (Of a three-electrode tube.) The second derivative of the plate current with respect to the grid voltage of a tube (used without grid condenser). It is a measure of the curvature of the plate current grid-voltage characteristic of a tube.

**Damped Alternating Current:** A current passing through successive cycles of value with progressively diminishing amplitude, the average value being zero.

**Damping Factor:** The product of the logarithmic decrement and the frequency of a logarithmically damped alternating current.

Let  $I_0$  = initial amplitude,  
 $I_t$  = amplitude at the time  $t$ ,  
 $e$  = base of Napierian logarithms (2.71828...)  
 $a$  = damping factor,  
 Then  $I_t = I_0 e^{-at}$

**Detector:** That portion of the receiving apparatus which, connected to a circuit carrying currents of radio frequency, and in conjunction with a self-contained or separate indicator, translates the radio-frequency power into a form suitable for operation of the indicator. This translation may be effected either by the conversion of the radio-frequency power, or by means of the control of local power. The indicator may be a telephone receiver, relaying device, tape recorder, and so on.

**Diplex Reception:** The simultaneous reception of two series of signals by a single operating station.

**Diplex Transmission:** The simultaneous transmission of two series of signals from a single operating station.

**Direct Coupling:** Association of two radio circuits by having an inductor, a condenser, or a resistor, common to both circuits.

**Direct-Current Characteristic:** The relation given by the curve plotted between the impressed electromotive force as abscissas and the resultant current as ordinates, for direct emf. and current.

**Direction Finder:** A radio receiving system which permits determination of the direction of the line of travel of received radio waves.

**Directive Antenna:** One having the property of radiating radio waves in larger proportion along some directions than others.

**Double Modulation:** The process of modulating a radio-frequency alternating current successively at two lower

**Radio Catalogue Free**

**Write us a post card—**

and we will send you free this 52 page catalogue of radio sets and parts. It also contains explanation of radio terms, map and list of broadcasting stations and much radio information, including an explanation of successful hook-ups and circuits.

You will be amazed at the low prices Ward's quote. A complete set for \$32.50 equalling sets at \$60 elsewhere—a \$23.50 set that under favorable conditions has a radius of 500 miles and more.

This catalogue contains everything for the expert and amateur. Complete sets and every improved part for building sets, all the most up-to-date devices—at the lowest possible prices.

**Headquarters for Radio**

Montgomery Ward & Co. is headquarters for Radio, selling everything direct by mail without the usual "Radio-profits." Why pay higher prices? Ward quality is the best and the prices will often save you one-third. Everything sold under our Fifty Year Old Guarantee,—Your Money Back if You Are Not Satisfied. Write today for your copy of this complete 52-page Radio Book.

**Write to the house nearest you. Address Dept. 2-R**  
 Chicago Kansas City St. Paul Portland, Ore. Fort Worth

**Montgomery Ward & Co.**  
 The Oldest Mail Order House is Today the Most Progressive

**The Standard AMERICAN Transformers**

Audio and Radio Frequency

are being used in radio sets manufactured by leaders in the industry.

These manufacturers have expended a great deal of time and money in the testing of transformers to give best results. They can not afford to take chances. Their preference of "All-American" Transformers is your guide to real satisfaction.

Ask your dealer to show you "All-American" Transformers. Handsome in appearance, accurate in design, splendid results always; you will want them for your set.

**Free Offer** Book of Hook-ups containing twenty-five successful circuits. Send 2c stamp to cover postage.

**RAULAND MFG. CO.**  
 200 No. Jefferson St., Chicago, Ill.

Radio Frequency Transformer

Audio Frequency Transformer

**WANTED**—Back numbers of Radio News, Dec., 1921, Jan. and Feb., 1922. Experimenter Publishing Co., 53 Park Place, New York City.

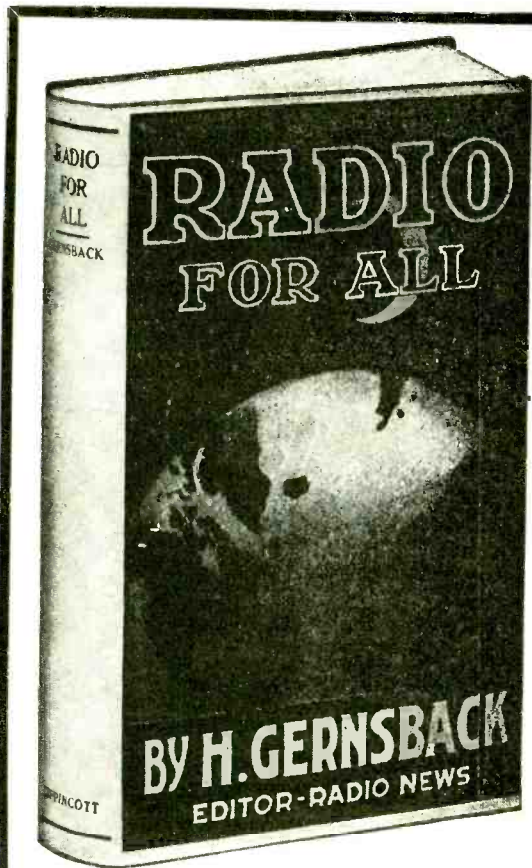

# RADIO FOR ALL

By H. GERNSBACK

Editor "Radio News," "Science and Invention" and "Practical Electrics"

With over 130 illustrations and diagrams, and 12 photographs, 300 pages, size 8 3/4" x 5 1/2".

What the novice in radio needs is a book in which he can get all the information necessary for him to understand radio telephony and telegraphy, to make or buy a receiving set suitable to his means, to know how to operate his set, and after he has an understanding of the radio art, information that will enable him to advance and get the most out of his outfit. All this must ordinarily be dug out of text-books, pamphlets and government publications, but the aim of this book is to have all the data and information that the beginner will need from the time that he takes up radio. It is a permanent, comprehensive reference book for the dyed-in-the-wool dabbler in Radio.

### What the Book Is.

A combination of a radio course for the novice in radio telephony and telegraphy with a reference book for the more experienced amateur. Half a dozen books in one.

### For the Beginner.

- The theory of radio carefully explained with drawings.
- Description of and instruction for operating instruments of receiving and sending sets, with all picture diagrams of the wiring of the apparatus.
- How to make your own receiving set, costing from \$3.00 to \$50.00.
- How to read diagrams; for every picture diagram there is a corresponding technical diagram using the symbols instead of drawings.
- How to tune sharply and eliminate interference from other stations.
- How to protect your set from lightning and the laws regarding installation.
- Explanation of time and weather signals.

### For the More Experienced Amateur.

- How to make a practical vacuum tube detector, two stage amplifier set costing less than \$50.00, that will work.
- How the radio compass works.
- All about underground aerials, loop aerials and directional aerials.
- Formulae for finding wave length; miscellaneous formulae for finding capacity of condenser and other instruments. Tables of wire resistances, wave lengths and their corresponding frequencies, approximate wave lengths for different aerials, tuning coil data, and much more invaluable information.

### Special Features.

- Lists of all the broadcasting stations in the United States and Canada for concerts, time signals, weather reports, press, stock market reports, etc., with their call, wave length and time of sending.
- Detailed description of Washington weather signals and their translation.
- Description of a modern broadcasting station and its operation.
- Large map showing location of all U. S. radio telephone broadcasting stations suitable for hanging up in radio room.
- Collection of miscellaneous radio information for the amateur.

### In Other Words.

The information that you ordinarily have to dig out of government publications, text-books, pamphlets, etc., is handily combined in this one book.

The Complete Book of All Radio Information

PRICE POSTPAID

**\$2.00**

PRACTICAL ELECTRICS COMPANY

:: :: 53 PARK PLACE, NEW YORK CITY

# Each a Leader In Its Field

## Science & Invention

Is one of the most interesting magazines published. It is more interesting than fiction.

It is profusely illustrated and covers in word and picture the latest achievements in the sciences—in Invention, Astronomy, Physics, Chemistry, Electrics, Mechanics, etc.

It has a large section devoted exclusively to Radio. SCIENCE & INVENTION has the distinction of being more often quoted than any other magazine in the world.

More than 100 large pages—with over 300 illustrations, drawings, etc.

Special prize contests are offered each month.

On all newsstands, 25c a copy.

## Radio News

"The 100 Per Cent Wireless Magazine"

The Largest Radio Magazine in the World

Is read by more than a million Radio enthusiasts each month.

Its position as the leader of all Radio publications is universally recognized by dealers, radio manufacturers and every branch of the radio industry and its pages reflect their confidence.

RADIO NEWS contains more articles by Radio Experts—more specific information—detailed drawings—illustrations and news—than is published in any other magazine.

More than 200 large pages monthly. Profusely illustrated.

On all newsstands, 25c a copy.

## Subscription Prices

|                     |   |
|---------------------|---|
| Science & Invention | } One Year<br>12 Issues<br>\$2.50<br>Each |
| Radio News          |   |

of each magazine  
(Add 50c to the cost  
for Canada or

**FREE PRESENTS FOR  
SUBSCRIPTION  
RAISERS.**

Write for our  
Premium Catalog  
containing valuable  
rewards given away  
**FREE.**

Premium Dept.  
Experimenter Pub. Co.  
53 Park Place, N. Y.

Experimenter Publishing Co., Inc., 53 Park Place, New York, N. Y.



frequencies. The intermediate frequency is usually above the range of audio frequencies. The lowest frequency is generally an audio frequency or combination of audio frequencies, as in radio telephony.

**Down Lead:** That portion of a transmitting or receiving antenna which serves to connect the larger portion of an antenna or the main elevated conductor to the transmitting or receiving set, or through tuning inductors or condensers to the ground connection or counterpoise system.

**Duplex Signaling:** The simultaneous transmission and reception of signals in both directions between two stations.

**Dynatron:** A three-electrode tube which depends for its action upon the liberation of electrons from an anode by electron bombardment.

**Effective Height of an Antenna:** The effective height of an antenna is the product of the Form Factor and the height from ground or counterpoise to the highest point of the antenna. The effective height of an antenna can be determined by measuring  $H_1$ , the average height of the main elevated portion of the antenna; calculating  $C_1$ , the capacity of the main elevated portion of the antenna, disregarding the effect of masts, towers, guys, down leads, trees, etc.; and measuring  $C_2$ , the actual capacity of the antenna, after construction, at low frequency. Then

$$\text{Effective Height: } H = H_1 \times \frac{C_1}{C_2}$$

The radiating properties of the antenna for any wave-length are determined by the formula

$$\text{where } Rr = 1580 \frac{H^2}{\lambda}$$

$Rr$  = Radiation Resistance  
 $H$  = Effective Height of Antenna in Meters  
 $\lambda$  = Wave-length in Meters

The radiation resistance thus obtained is correct for antennae operating at wave-lengths considerably in excess of the natural period of the antenna and will be approximately correct for antennae operating at wave-lengths of the same order as the natural wave-length of the antenna, when the dimensions of the horizontal portions of such antenna are large compared with the vertical dimensions. The radiation resistance for a straight vertical antenna operating at a wave-length near the natural period of the antenna can only be determined accurately by very complicated calculations and if the above formula is used, the radiation resistance obtained will generally be less than the actual radiation resistance by about 25 per cent.

**Electron Tube, Three Electrode:** See Three Electrode Tube.

**Electron Tube Rectifier:** A device for rectifying an alternating current by utilizing electron flow between a hot cathode and a relatively cold (relatively less) electron-emissive anode in a vacuum.

**Electrostatic Coupling:** See Capacity Coupling.

(To be continued in next issue.)

**SERVICE IMPROVES**

Discrepancies in transmission of messages by the Navy have been decreased markedly during the past six months. During a recent period of supervision, five Atlantic stations had no errors, while only two out of the other seven had over one-tenth of a word in a thousand wrong. Manipulation has improved greatly, operators are better instructed in procedure and are more attentive, the report states.



**Natural Re-PRODUCTION**  
**Atlas**  
**AMPLITONE**  
**LOUD SPEAKER**

**BLAST** and distortion conquered!!! Patented "double-diaphragm" re-PRODUCES the full range of musical sounds with absolute fidelity. Adjustable to varying receiving conditions. The most advanced type loudspeaker.

Hear the difference when your dealer demonstrates the Atlas Amplitone \$25.

Write for Booklet "F"  
 Letters from Users Requested  
 What have you accomplished with your Atlas Amplitone? Tell us about it.

**Multiple Electric Products Co. Inc.**  
 ORANGE ST., RADIO DIVISION NEWARK, N. J.

**Add These Books To Your Library**

**The How and Why of Radio Apparatus**



By H. W. Secor, E.E.

This newest book on radio matters fills a distinct gap in wireless literature. While the treatment is made as understandable and as free from mathematics as possible, it at the same time incorporates a wealth of technique and instruction for the Radio Amateur—the Radio Operator—the Installation and Designing Expert—as well as teachers and students of the subject in general.

A very broad field has been covered by the author, giving a great amount of information not found in other text-books. If you are engaged in any branch of the Radio or allied arts you will surely need this latest contribution to radio literature.

This newest of Radio Work has 160 pages, 6 x 9 inches. Hundreds of illustrations and tables. Cloth bound in Vellum de Luxe, stiff covers, hand-sewed, gold stamped, each **\$1.75**  
 Same book, limp binding, colored cover \$ .75

**Experimental Electricity Course in 20 Lessons**



By S. Gernsback and H. W. Secor, E.E.

Every phase of experimental electricity is treated comprehensively in plain English. New Experiments are described and explained and nearly every application of Electricity in modern life is given in simple language.

A masterpiece. Explains every electrical device from a push button and bell to the biggest generator made. Worth its weight in gold for the man who wishes to know about electricity, and to the experimenter it is still more valuable because of its many facts, tables, etc.

The Best Electrical Text-Book on the Market. Size of Book is 6 x 9 inches.

The book contains 128 pages and more than 400 illustrations.

Cloth bound, stiff covers, hand-sewed, green and black stamped. **\$1.25**  
 each

**DEALERS--Ask for wholesale discount**

**EXPERIMENTER PUBLISHING CO., Inc. 53 Park Place, N. Y.**

# OPPORTUNITY AD-LETS

Follow these advertisements every month. Reliable advertisers from all over the country offer their most attractive specials in these columns.

Classified advertising rate fifteen cents a word for each insertion. Ten per cent discount for 6 issues, 20 per cent discount for 12 issues. Name and address must be included at the above rate. Cash should accompany all classified advertisements unless placed by an accredited advertising agency. No advertisement for less than 10 words accepted.

Objectionable or misleading advertisements not accepted. Advertisements for the November issue must reach us not later than September 1st.

**THE Net Paid CIRCULATION OF RADIO NEWS IS OVER 200,000**

EXPERIMENTER PUBLISHING CO., INC., 53 Park Place, New York, N. Y.

## Agents Wanted

**Big Money and fast sales.** Every owner buys gold initials for his auto. You charge \$1.50; make \$1.35. Ten orders daily easy. Write for particulars and free samples. American Monogram Co. Dept. 133, East Orange, N. J.

**Make 16,000 miles without a puncture.** Insyde Tyres positively prevent punctures and blowouts. Double tire mileage, any tire, old or new. Use over and over again. Low priced. Agents wanted. Write for terms. American Accessories Co., B-392, Cincinnati, Ohio.

**Men's Shirts.** Easy to sell. Big demand everywhere. Make \$15.00 daily. Undersell stores. Complete line. Exclusive patterns. Free samples. Chicago Shirt Manufacturers, Franklin & Van Buren, Factory 120, Chicago.

**Earn big money fast applying gold initials to autos.** Every owner buys—\$1.35 profit on \$1.50 sale—particulars and samples free. Write quick. Lithogram Co., Dept. 32, East Orange, N. J.

**We want Salesmen and Agents,** either whole or side line, to sell our low priced radio books to the trade. Excellent proposition for live wires. The E. I. Company, Publishers, 233 Fulton Street, New York City.

**Agents Wanted** in every city and town to sell standard radio apparatus. Attractive discounts given. If interested, write or call once stating age and radio experience. Wilmington Electrical Specialty Co., Inc., 912 Orange St., Wilmington, Delaware.

## American Made Toys

**Manufacturers on Large Scale,** also homeworkers, wanted to manufacture Metal Toys and Novelties. Millions needed of Barking Dogs, Wag Tail Pups, Wild Animals, Automobiles, Indians, Cowboys, Baseball Players, Cannons, Toy Soldiers, Crowing Roosters, Statues of Liberty, Miniature castings of Capitol, Bathing Girl Souvenirs and others. Unlimited possibilities. Guaranteed Casting forms furnished manufacturers at cost price from 75.00 up, with complete outfit. No experience or tools necessary. Thousands made complete per hour. We buy goods all year and pay high prices for finished goods. Cash on delivery. Contract orders placed with manufacturers. Catalog and information free. Correspondence invited only if you mean business. Metal Cast Products Co., 1696 Boston Road, New York.

## Business Opportunities

**Sell us your spare time.** You can earn Fifteen to Fifty dollars weekly writing showcards at home. No canvassing, pleasant, profitable profession easily, quickly learned by our simple graphic block system, artistic ability unnecessary, we instruct you and supply work. Wilson Methods, Limited, Dept. J, Toronto, Canada.

**Become a Landscape Architect.** Dignified, Exclusive Profession. Little competition. \$5,000.00 to \$10,000.00 income for experts. Easy by our method. Begin earning 3 weeks after you enroll. Write today. American Landscape School, 1116 Newark, N. Y.

**Make Money At Home.** Part or spare time, casting metal toys. Particulars free. New Specialty Co., 418 E. 79th St., New York.

**Operate a Tire Repair Shop!** Big Profits! Oldham made \$2200 in 4 months. Evans averages \$100 week. We teach you and furnish full equipment for \$100 up. Write quick. Hayward's, 1331 South Oakley Ave., Chicago.

## Help Wanted

**We want Salesmen and Agents,** either whole or side line, to sell our low priced radio books to the trade. Excellent proposition for live wires. The E. I. Company, Publishers, 233 Fulton Street, New York City.

**Detectives Needed Everywhere.** Work home or travel. Experience unnecessary. Write, American Detective System, 1968 Broadway, N. Y.

**Be a Mirror Expert.** \$3-\$10 a day; spare time home at first; no capital; we train, start you making and silvering mirrors. French method. Free prospectus. W. R. Derr, Pres., 26 McKinley St., Baldwin, N. Y.

**All men, women, boys, girls, 17 to 60,** willing to accept Government Positions, \$117-\$190, traveling or stationary, write, Mr. Ozment, 251, St. Louis, Mo., immediately.

**\$100 to \$300 a Week.** Men with slight knowledge of motors who can reach car owners can earn \$300 weekly without making a single sale. If they can also make sales their profits may reach \$25,000 yearly. Only proposition of its kind ever offered. V. K. Phillips, 1908 Broadway, New York.

**Earn \$25 Weekly,** spare time, writing for newspapers, magazines. Experience unnecessary; details free. Press Syndicate, 5665, St. Louis, Mo.

## Books

**Radio Books Latest and Best.** Catalog free. Ray Dobbins, 116 West 27th St., Indianapolis, Ind.

**"Lights, Colors, Tones and Nature's Finer Forces",** including Vibrations, colors; Electromagnetics; Odic-auras; Radio; Coldlights; Inventions; Marvelous Opportunities. Illustrated; 270 pages, \$2.00. Table contents free. Stevens Publishers, 212 Powell, San Francisco, Calif.

**The How and Why of Radio Apparatus,** by H. W. Secor, E. E. This newest book on radio matters fulfills a distinct gap in wireless literature in that, while the treatment is made as understandable and as free from mathematics as possible, it at the same time incorporates a wealth of technique and instruction for the Radio Amateur—the Radio Operator—the Installation and Designing Expert—as well as teachers and students of the subject in general. A very broad field has been covered by the author, at the same time giving a great deal of information not found in other text books. If you are engaged in any branch of the Radio or allied arts at all you will surely need this latest contribution to radio literature, which is destined to be found on every radio man's book shelf before long. A glance at the following list of chapters gives but a very scant idea of the extensive and useful radio knowledge provided in its text: The Induction Coil; The Alternating Current Transformer; Radio Transmitting Condensers; The Spark Gaps; Radio Transmitting Inductances; Radio Receiving Tuners; Radio Receiving Condensers; Detectors; Telephone Receivers; Radio Amplifiers; Construction of a Direct Reading Wavemeter and Decimeter; Antenna Construction; The Calculation and Measurement of Inductances; Appendix containing very useful tables, covering all subjects treated in this very unusual book. This newest of Radio Works, cloth bound in Velum de Luxe, Gold Stamped and Hand Sewed, has 160 pages. Size of book, 6x9 inches. The How and Why of Radio Apparatus. Postpaid, \$1.75. Experimenter Publishing Co., Book Dept., 53 Park Place, New York City.

**Experimental Electricity Course in 20 Lessons.** By S. Gernsback and H. W. Secor, E. E. A course of the theory and practice of Electricity for the Experimenter. Every phase of experimental electricity is treated comprehensively in plain English. New experiments are described and explained and nearly every application of Electricity in modern life is given. 160 pages—400 illustrations. Pleasure cloth cover. 75c. postpaid. Stiff cloth cover, \$1.25 postpaid. Experimenter Publishing Co., Book Dept., 53 Park Place, New York City.

**Wireless Course in 20 Lessons.** By S. Gernsback, A. Lescaurba and H. W. Secor, E. E. Tells you everything you want to know about "Wireless"—theory, practice and history. A clear, concise course on every phase of this subject. 160 pages—350 Illustrations, 30 tables. Stiff cloth cover, \$1.75, postpaid. Experimenter Publishing Co., Book Dept., 53 Park Place, New York.

**How to Make Wireless Receiving Apparatus.** 100 pages—90 Illustrations. Only strictly modern radio apparatus are described. In this book and the Illustrations and descriptions are so clear and simple that no trouble will be experienced in making the instruments. Paper covered, 35c. postpaid. Experimenter Publishing Co., Book Dept., 53 Park Place, New York City.

**How to Make Wireless Sending Apparatus.** 100 pages—88 illustrations. Written and published entirely for the wireless enthusiast who wants to make his own radio apparatus. Contains more information on "How to make it" than any other book we know of. Paper bound 35c. postpaid. Experimenter Publishing Co., Book Dept., 53 Park Place, New York City.

**How to Make Radio Frequency Amplifiers.** This book is for the more advanced amateur, showing the construction of the Radio Frequency Amplifying Transformer and giving complete constructional data. It shows the application of Radio Frequency to amplifying units that the amateur may already possess and gives 15 hook-ups showing practically every use Radio Frequency Amplifying Transformers can be put to. 32 pages, 15 illustrations; bound in beautiful two-color cover. Prepaid 25c. The E. I. Company, 233 Fulton St., New York City.

**Major Armstrong's New Epoch-Making Invention Will Solve Your Loop Antenna Problem.** The New Armstrong Super-Regenerative Circuit is a means now that is made possible with two vacuum tubes and an indoor loop antenna to receive broadcasting music up to 100 miles distant. Our engineering department has compiled a pamphlet that gives an exposition of the theory of operation with full working directions, etc. A large blue-print is included with this pamphlet. Your dealer cannot supply you with these pamphlets. Send us 25c and we will mail to you this wonderful exposition prepaid. Tell your dealer to ask us for our proposition. The E. I. Company, 233 Fulton St., New York City.

**Science and Invention Bound Volume No. 9.** May 1921-April 1922; contains 1200 pages with over 1500 illustrations and over 700 articles by the foremost American and Foreign writers. We have also a limited amount of the following Bound Volumes of Science and Invention (Electrical Experimenter) Vol. No. 6—May 1918 to April 1919; Vol. No. 7—May 1919 to April 1920; Vol. No. 8—May 1920 to April 1921. Each volume bound in stiff board covered with green vellum and gold stamped. Price for volume No. 9—\$2.25. Price for volume No. 6, 7 or 8—\$2.00. All four volumes \$7.00, sent express collect. Experimenter Publishing Co., 53 Park Place, New York City.

## Chemistry

**"Popular Chemist," Magazine.** "The Experimenter's Monthly," "Six months" trial, 45c. C. Wright Laboratory, Caldwell, New Jersey.

**Learn Chemistry at Home—Dr. T. O'Connor Sloane,** noted educator and scientific authority, will teach you. Our home study correspondence course fits you to take a position as chemist. See our full page ad on page 295 of this issue. Chemical Institute of New York, 66 West Broadway, New York City.

## Correspondence Courses

**Used Correspondence Courses and educational books bought and sold.** Attractive prices. Educational Service, West Park Ave., Piqua, Ohio.

**Dollars Saved—Used correspondence courses of all kinds sold, rented and exchanged.** List free. (Courses bought.) Lee Mountain, Pisgah, Alabama.

## Exchange

**200-20,000 Meter Receiver including Radlotron \$35.00, Two Step Amplifier \$22.00.** Smith, 1116 Market, Philadelphia, Pa.

**1500 mile Vacuum tube receiver \$21.50.** Radio, 4116 Market, Philadelphia.

**Edison Elements for Storage B Batteries,** Six to ten cents per pair postpaid. (Depending solely on size of order). I handle strictly first grade elements only. A. J. Hanks, 608 Montgomery Street, Jersey City, N. J.

## For Inventors

**Inventor's Educator.** 900 Mechanical Movements, 50 Perpetual Motions. How to procure and sell patents. Mechanical Movements greatly assist Inventors, suggest new ideas. Explains how to select an attorney and avoid Patent Sharks. Price, \$1.50. Postage free. Fred G. Dietrich Co., 601 Orin Building, Washington, D. C.

## Health

**Enjoy Health Through Right Eating.** Literature free. The Apptropher, 1916 No. Harding Ave., Chicago, Ill.

## Improved Made Toys

**We show you how to earn big money easily** with our casting forms making Whistling Birds, Wild Animals, Crowing Roosters, Automobiles, Baseball Players, Statue of Liberty, Indians, Toy Soldiers, Cowboys, Barking Dogs, Wag Tail Pups, Miniature castings of Capitol, Bathing Girl Souvenirs and others. No experience necessary. We furnish you with molds and necessary outfit from \$5.50 up. We buy large quantities of finished goods at highest prices. Spot cash. Send for catalogue and information free. The Improved Metal Casting Co., 312 East 145th Street, New York.

## Instruction

**Learn Chemistry at Home—Dr. T. O'Connor Sloane,** noted educator and scientific authority, will teach you. Our home study correspondence course fits you to take a position as chemist. See our full page ad on page 295 of this issue. Chemical Institute of New York, 66 West Broadway, New York City.

**Used Correspondence Courses bought and sold.** Bargain catalogue 1,000 courses free. Students' Exchange, Dept. 5, 47 West 42 St., New York.

## Mail Order Business

**Advertise.** Newspapers, magazines. List on request. Pennell Company, Covington, Kentucky.

## Motorcycles—Bicycles

**Don't buy a Bicycle Motor Attachment until you get our catalog and prices.** Shaw Mfg. Co., Dept. 8, Galveston, Kansas.

## News Correspondents

**Earn \$25 Weekly Spare Time writing for newspapers, magazines.** Experience unnecessary; details free. Press Syndicate, 566 St. Louis, Mo.



## Languages

**World-Romic System.** Mastery to All Languages. Primers, 25 languages, \$1.04 each language: English, French, German, Italian, Portuguese, Spanish. Pronunciation-Tables 102 languages, 30c each language. Languages Publishing Company, 8 West 40th Street, New York.

## Miscellaneous

**Real Airplane Propellers.** New 8' Beautiful Finish. Bright Copper Tins. Decorate your den, \$5.00 ea. Crated from Middletown, Penna. Air Transport Co., L. I. City, N. Y.

**A Radio Designer of Receiving Sets and Circuits** that is confined to his home desires connection with reliable firm or persons needing special problems or circuits worked out. Miniature Portable Tube Sets a specialty. Write Box 130, Radio News.

**Don't Incorporate.** Organize any enterprise under common law; any capital; transact business any state; no corporation taxes; no personal liability; raise capital; booklet free. Herbert Company, 9 Rand McNally Building, Chicago.

**Make money with your camera.** Lancaster, Box 967, Los Angeles.

**Springs made to order.** Wright Bros. Spring & Wire Works, 5616 Huron St., Chicago.

**Buy your cigars direct.** 50 Aromor prepaid, \$1.50. Money back if dissatisfied. Agents wanted. Havana Smokehouse, Homeland, Ga.

## Office Devices

**Save half on office machines, equipment, addressers, Multigraphs, Duplicators, Dictaphones.** Pruitt Company, 172 North Wells, Chicago.

## Patent Attorneys

**Inventors: Protect your invention** through A. M. Wilson, Inc., Washington, D. C. Over 25 years of efficient, expert, confidential service. Skilled in Radio-Electrical, Chemical and Mechanical fields. Our new Illustrated Patent Book, giving much necessary and very useful information which every inventor should know, will be sent free upon request. Prompt and careful attention. Highest references. Moderate fees. Send sketch or model for our careful opinion and preliminary advice. Write today to A. M. Wilson, Inc., (Radio 3 ARH), 325 Victor Bldg., Washington, D. C.

**Millions spent annually for ideas!** Hundreds now wanted! Patent yours and profit! Write today for free books—tell how to protect yourself, how to invent, ideas wanted, how we help you sell, etc., 301 Kresge Bldg., American Industries, Inc., Washington, D. C.

**Patents.** Send drawing or model for examination and report as to patentability. Advice and booklet free. Highest references. Best results. Promptness assured. Watson E. Coleman, Patent Lawyer, 624 F Street, Washington, D. C.

**Patents—Inventors should write for Free Guide Books and Record of Invention Blank** before disclosing invention. Send model or sketch of your invention for our free opinion of its patentable nature. Radio Electrical, Chemical, Mechanical and Trade-Mark experts. Victor J. Evans & Co., 922 Ninth, Washington, D. C.

**Patent.** Electrical cases a specialty. Pre-war charges. S. P. Fishburne, 310 McGill Bldg., Washington, D. C.

**Patents secured.** Prompt service. Avoid dangerous delays. Send for our "Record of Invention" form and Free Book telling how to obtain a Patent. Send sketch or model for examination. Preliminary advice without charge. Highest references. Write Today. Jacobl & Jacobl, 413 Ouray Bldg., Washington, D. C.

**Patents—Send for form "Evidence of Conception"** to be signed and witnessed. Form, fee schedule, information free. Lancaster and Alwine, 269 Ouray Bldg., Washington, D. C.

**Patent Sense.** The Book the Inventor Keeps. Free. See Lacey's ad, page 350.

**Inventors!** Record invention legally before disclosing to others. Our Invention-Record and Data Sheet shows how. Send free and valuable information given on patent procedure, costs, etc. Report on patentability includes copies of patents nearest your idea. O'Connell & O'Connell, 402 Jenifer Building, Washington, D. C.

**Patents Procured.** Send sketch or model today for examination, prompt report and advice. No charge for preliminary advice. Write for free booklet and blank form on which to disclose your idea. Highest references. Promptness assured. Clarence A. O'Brien, Registered Patent Lawyer, 751 Southern Building, Washington, D. C.

**Patents and Trade-Marks.** 64-page Book free. Excellent references. 23 years' experience. Robb, Robb & Hill, 1309 Hanna Bldg., Cleveland, Ohio. 948 McLachlen Bldg., Washington, D. C.

**Patent applications filed on partial payment plan.** Trade-marks; copyrights. Milo B. Stevens & Co., 632 F St., N. W., Washington, D. C.

## Salesmen Wanted

**Lightning—Strange Battery Compound.** Charges discharged batteries instantly. Eliminates old method entirely. Gallon free to agents. Lightning Co., St. Paul, Minn.

## Scenery to Rent

**Settings for Opera, Plays, Minstrels. Plush Drops.** Address Amelia Grain, Philadelphia.

## Patents

**Inventions Commercialized.** Patented or unpatented. Write Adam Fisher MFG. Co., 278, St. Louis, Mo.

**Unpatented Ideas can be sold.** I tell you how and help you make the sale. Particulars free. Write W. A. Greene, Jenifer Building, Washington, D. C.

## Patents For Sale

**Patent For Sale.** Novelty Wireless Detectors Finger Ring and Stick Pin. Harry Ruf, 511 Chestnut St., Roselle Park, New Jersey.

## Personal

**Lonesome—Join our club—make acquaintances everywhere.** Big illustrated book with descriptions and photos, sent in plain wrapper for ten cents. Bonafide Co., Dept. 58, Kansas City, Mo.

**Exchange interesting letters with new friends.** Dolly G. Gray, Box 186, Denver, Colo.

**Exchange cheery letters with new friends.** Write Betty Lee, Inc., 4254 Broadway, New York City. Stamp appreciated.

**Exchange letters with new friends everywhere.** Pleasant pastime, particulars free—Smith, Box 1167Y, Denver, Colo.

**Your Horoscope.** Business, Changes, Social, Matrimonial prospects. Send birthdate and 10 cents (stamps) for remarkable test reading. Zanya, G-202 West 105th St., New York.

## Telegraphy

**Learn Wireless Code in 45 Minutes.** Radio Code Chart and Code Cards only \$1 complete. Stamp brings particulars. John Percival, 2115 York, Des Moines, Iowa.

**Telegraphy—Both Morse and Wireless** taught thoroughly and quickly. Tremendous demand. Big salaries. Wonderful opportunities. Expenses low; chance to earn part. School established fifty years. Catalog free. Dodge's Institute, Cour St., Valparaiso, Ind.

## Wanted to Buy

**Full Value Paid for Old Gold Jewelry, Watches, Diamonds, crowns, bridges, dental gold, silver, platinum, gold or silver ore, magnet points, old false teeth.** Packages returned if our offer is not satisfactory. United States Smelting Works (The Old Reliable), 120 So. State St., Dept. 16, Chicago, Ill.

## Wireless

**The How and Why of Radio Apparatus,** by H. W. Secor, E. E. This newest book on radio matters fulfills a distinct gap in wireless literature in that, while the treatment is made as understandable and as free from mathematics as possible, it at the same time incorporates a wealth of technique and instruction for the Radio Amateur—the Radio Operator—the Installation and Designing Expert—as well as teachers and students of the subject in general. A very broad field has been covered by the author, at the same time giving a great deal of information not found in other text books. If you are engaged in any branch of the Radio or allied arts at all you will surely need this latest contribution to radio literature, which is destined to be found on every radio man's book shelf before long. A glance at the following list of chapters gives but a very scant idea of the extensive and useful radio knowledge provided in its text: The Induction Coil; The Alternating Current Transformer; Radio Transmitting Condensers; The Spark Gaps; Radio Transmitters; Inductances; Radio Receiving Tuners; Radio Receiving Condensers; Detectors; Telephone Receivers; Radio Amplifiers; Construction of a Direct Reading Wavemeter and Decimeter; Antenna Construction; The Calculation and Measurement of Inductances; Appendix containing very useful tables, covering all subjects treated in this very unusual book. This newest Radio Works, cloth bound in Vellum de Luxe, Gold Stamped and Hand Sewed, has 160 pages. Size of book 6x9 inches. The How and Why of Radio Apparatus. Postpaid, \$1.75. Experimenter Publishing Co., Book Dept., 53 Park Place, New York City.

**Experimental Electricity Course in 20 Lessons.** By S. Gernsback and H. W. Secor, E. E. A course of the theory and practice of electricity for the experimenter. Every phase of experimental electricity is treated comprehensively in plain English. New experiments are described and explained, and nearly every application of electricity in modern life is given. 160 pages—100 illustrations. Flexible cloth cover, 75c, postpaid. Stiff cloth cover, \$1.25, postpaid. Experimenter Publishing Co., Book Dept., 53 Park Place, New York City.

**Wireless Course in 20 Lessons.** By S. Gernsback, A. Lescaour and H. W. Secor, E. E. Tells you everything you want to know about "Wireless"—theory, practice and history. A clear, concise course on every phase of this subject. 160 pages—350 illustrations, 30 tables. Stiff cloth cover, \$1.75, postpaid. Experimenter Publishing Co., Book Dept., 53 Park Place, New York City.

**How to Make Wireless Receiving Apparatus.** 100 pages—90 illustrations. Only strictly modern radio apparatus are described in this book and the illustrations and descriptions are so clear and simple that no trouble will be experienced in making the instruments. Paper covered, 35c, postpaid. Experimenter Publishing Co., Book Dept., 53 Park Place, New York City.

**How to Make Wireless Sending Apparatus.** 100 pages—88 illustrations. Written and published entirely for the wireless enthusiast who wants to make his own radio apparatus. Contains more information on "how to make it" than any other book we know of. Paper bound, 35c, postpaid. Experimenter Publishing Co., Book Dept., 53 Park Place, New York City.

## Wireless—Continued

**Wireless Course in 20 Lessons.** By S. Gernsback, A. Lescaour and H. W. Secor, E. E. Tells you everything you want to know about "Wireless"—theory, practice and history. A clear, concise course on every phase of this subject. 160 pages—350 illustrations, 30 tables. Stiff cloth cover, \$1.75, postpaid. Experimenter Publishing Co., Book Dept., 53 Park Place, New York.

**How to Make Wireless Receiving Apparatus.** 100 pages—90 illustrations. Only strictly modern radio apparatus are described in this book and the illustrations and descriptions are so clear and simple that no trouble will be experienced in making the instruments. Paper covered, 35c, postpaid. Experimenter Publishing Co., Book Dept., 53 Park Place, New York City.

**How to Make Wireless Sending Apparatus.**—100 pages—88 illustrations. Written and published entirely for the wireless enthusiast who wants to make his own radio apparatus. Contains more information on "how to make it" than any other book we know of. Paper bound, 35c, postpaid. Experimenter Publishing Co., Book Dept., 53 Park Place, New York City.

**How to Make Radio Frequency Amplifiers.** This book is for the more advanced amateur, showing the construction of the Radio Frequency Amplifying Transformer and giving complete constructional data. It shows the application of Radio Frequency to amplifying units that the amateur may already possess and gives 15 hook-ups showing practically every use Radio Frequency Amplifying Transformers can be put to. 32 pages, 15 illustrations; bound in beautiful two-color cover. Prepaid 25c. The E. I. Company, 233 Fulton St., New York City.

**Major Armstrong's New Epoch-Making Invention** Will Solve Your Loop Antenna Problem. The New Armstrong Super-Regenerative Circuit is a means now that is made possible with two vacuum tubes and an indoor loop antenna to receive broadcasting music up to 100 miles distant. Our engineering department has compiled a pamphlet that gives an exposition of the theory of operation with full working directions, etc. A large blue-print is included with this pamphlet. Your dealer cannot supply you with these pamphlets. Send us 25c and we will mail to you this wonderful exposition prepaid. Tell your dealer to ask us for our proposition. The E. I. Company, 233 Fulton St., New York City.

**Radio Cabinets—Better Cabinets at lower prices—Marvin R. Fallgatter, Waupaca, Wis.**

**Special Tubes UV201, UV201A, UV199, WD11, WD12, C301, C301A, C299, Dv-1, Dv-6, \$5.50; Electric Soldering Iron, \$2.25; Bradleystats, \$1.60; Radiola (RC) or (V) complete, \$123.65; Amp. Transformer, \$2.50; Bakelite Voltmeters and Couplers, \$5.00; Patent Plugs, \$4.5; Radiola Sr., \$58.75; Crystal Receivers, \$7.00. Dealers Wanted. C. H. Anderson, Lewistown, Mont.**

**Tweet Loop Arrangement** for long-distance Broadcasting and D.X. reception. No Radio Frequency—good work on detector only. Very simple. Description and diagram for one dollar. T. J. M. Daly, Little Rock, Ark.

**Build your own electrolytic storage battery charger.** Plates and complete instructions, \$1.00. Descriptive circular free. Peerless Electrical Parts Co., 105 Harris, Rochester, N. Y.

**Magnavox Type R3.** \$2 Latest nationally advertised improved reproducers in original factory sealed cartons. List \$35. Introductory offer, \$25. Radio Central, Dept. R, Abilene, Kansas.

**Pacific Coast Stations are heard in Pittsburgh with vario-coupler and two Rogers Receiving Radiometers (Condensite molded variometers), Radiometers \$1.00 each. Postage prepaid. Rogers Radio Company, No. 1153 Woodworth St., Pittsburgh, Pa.**

**Baldwin Headsets.** Super sensitive. Uncle Sam knows he uses them in his army and navy. List, \$12. Introductory, \$9.75. Radio Central, Dept. R, Abilene, Kansas.

**Copper Braid.** Best conductor known for wiring radio sets. Fifteen feet for 50c. Radio Panel Shop, Junction City, Kansas.

**All Radiator or Cunningham tubes** are supplied with premium correct thermostat or socket as a "get acquainted" offer. Radio Central, Dept. R, Abilene, Kansas.

**Protect Your Tubes** with small fuse wire between rheostats and sockets. Three feet for 25c. Specify tube. Radio Panel Shop, Junction City, Kansas.

**Brandes Matched Tone Radio Headsets** reproduce harmony as both receivers are exactly tuned. List \$8.00. Introductory offer \$6.75. Radio Central, Dept. R, Abilene, Kansas.

**Receiving Sets Overhauled,** repaired, rebuilt and made to "percolate." Any circuit. Twelve years experience and up-to-date. Radio Repair Shop, Junction City, Kansas.

**Boys! Don't Overlook This.** The "Rasco" Baby Detector. Greatest detector ever brought out with molded base. Fully adjustable. See former advertisements in this publication, or our catalog. Detector with Galena Crystal, complete 50c, the same detector with Radiocite Crystal, 75c, postpaid. Send for yours today. Radio Specialty Company, 96-98 Park Place, New York City.

**Attention!**—50 Vacuum tube hook-ups. The greatest collection of vacuum tube circuits ever brought under two covers at such insignificant cost. These diagrams will be found in the great "Rasco" catalog, which contains raw materials and parts in a greater profusion than any other catalog. 15c in stamps, or coin, will bring the catalog to you. Radio Specialty Co., 96-98 Park Place, N. Y.

**Build your sets** with quality parts and get sure results. Radio Parts Co., Box 56, Dunellen, N. J.



### A Remarkable Instrument

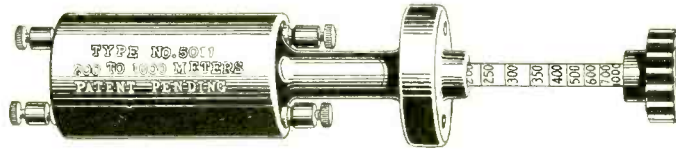

- DAY-FAN Audio Frequency Transformers
- Bakelite Variocouplers
- Bakelite Variometers
- Vernier Condensers
- 5, 10, 20, 30 Ohm Rheostats
- Potentiometers
- Knobs and Dials
- Wave Length Adapters

- DAY-FAN Complete Detector Units
- Complete Audio Frequency Amplifying Units
- Complete Radio Frequency Amplifying Units
- Mounted Variocouplers
- Mounted Variometers

THE result of eleven months' research and development in the radio laboratories of the Dayton Fan and Motor Company. For use in standard Radio Frequency, Reflex and Neutrodyne Circuits.

Tunes to any public broadcasting wave length. You are not getting all that is possible from a receiving set unless you have incorporated the principles underlying the Day-Fan Tuned Radio Frequency Transformer.

Write for an Instruction Sheet free of charge.

*Jobbers and Dealers, our new Catalog is ready.*

**The Dayton Fan and Motor Company**  
Dayton, Ohio  
Established 1889



# JUST OFF THE PRESS!!

12th Edition

\$2

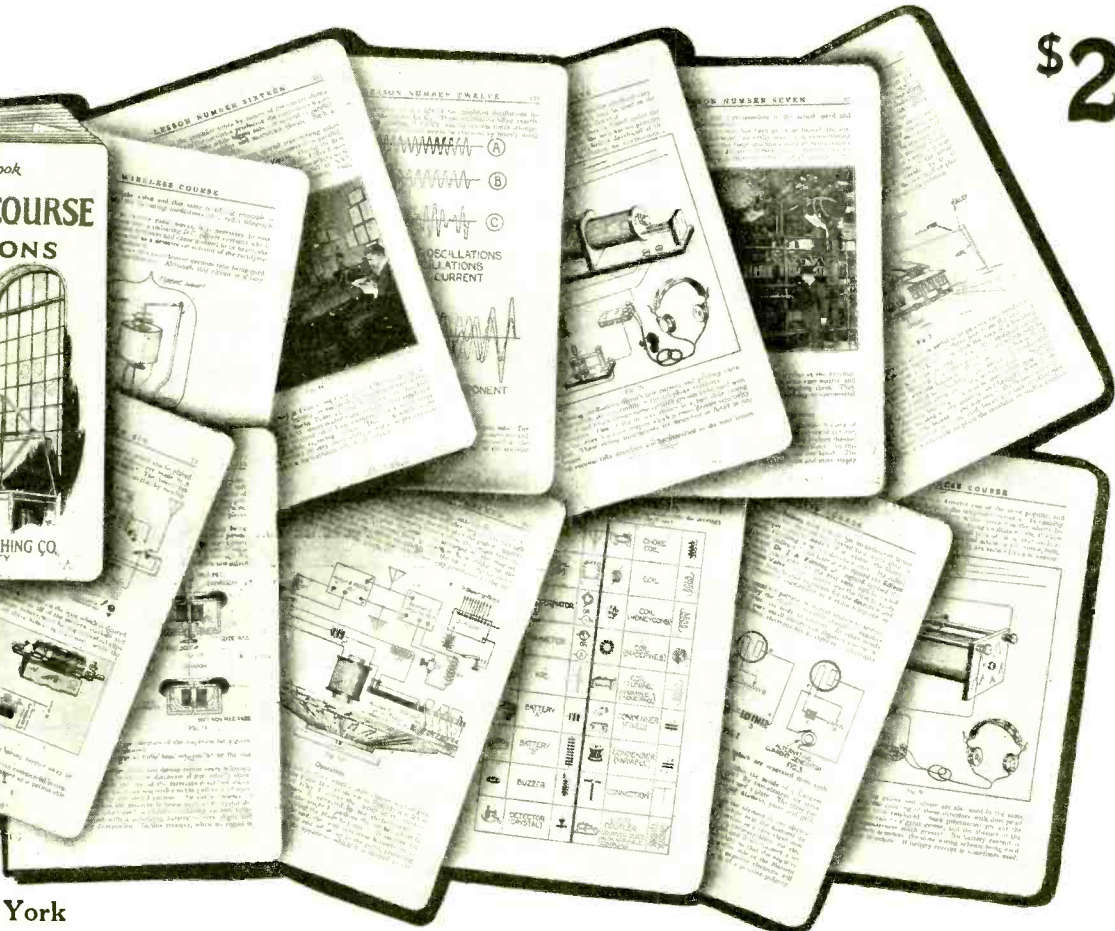
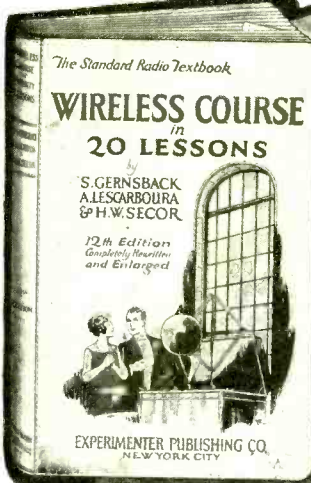

Mailed Postpaid on receipt of \$2.

Experimenters Publishing Co.  
53 Park Place, New York

# WORKRITE TRANSFORMER

**\$2.00**  
**EACH**



WORKRITE TRANSFORMER

**\$2.00**  
**EACH**

This Aircore Transformer has been perfected for use in the Neutrodyne method of receiving. Should be used with .0005 mfd. variable condenser for tuning to all broadcasting wave lengths. It can also be used as a transformer for tuned radio frequency reception, or fixed coupler with condenser across secondary. It is made with tubes of moulded bakelite and wound with green silk wire. Extreme care has been taken so that the tubes are properly spaced and just the right number of turns of wire are used, insuring maximum efficiency. Like all WorkRite instruments, it has been tested thoroughly by other laboratories as well as our own before being put on the market. It will measure up to the "WorkRite" standard of quality and efficiency.

WorkRite Nonmicrophonic Socket



WORKRITE NONMICROPHONIC SOCKET

Here is the right socket for use with your UV-199 Tube. It is moulded with a sponge rubber base in one piece which is even better than the soft rubber recommended for use with this tube. Very neat and attractive. Price ..... **60c**

WorkRite Resistance Cartridge



No need to buy a new Rheostat to get the 30 ohms resistance required for the UV-199 Tubes or the 15 ohms required for the 201-A and 301-A Tubes. Just put a WorkRite Resistance Cartridge in the circuit with your 5 or 6 ohm Rheostat. Price, **40c**  
15 or 25 ohm .....

WorkRite Super Vernier Rheostat

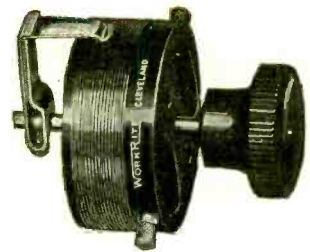

WORKRITE SUPER VERNIER RHEOSTAT

This improved WorkRite Vernier Rheostat is just the instrument you have been looking for. 50,000 possible adjustments. A turn of 1/33" will separate two stations or clear up one. Made in three different resistances so that there is a WorkRite Vernier Rheostat for every tube now on the market. 6 ohms, \$1.00; 15 ohms, \$1.10; 30 ohms, \$1.25.

**OTHER WORKRITE PRODUCTS**

WorkRite Super Variometer. Made from fine mahogany. Very sensitive and sharp tuning. Price ..... **\$3.50**

WorkRite 180° Super Variocoupler. Made from moulded Bakelite. Has 12 taps. Wound with green silk. Range 150 to 705 meters. Price..... **\$3.50**

WorkRite E-Z-Tune Dial. Snappiest Dial on the market. Has a knurled flange on the rim for delicate leverage. Price ..... **75c**

WorkRite type "A" Hyarometer. You need one for testing your storage "A" battery. Full instructions with each instrument. Price ..... **75c**

WorkRite Concert Head Set. Very sensitive. Light and sanitary. Try one and see. Price ..... **\$6.00**

WorkRite Switch Set. Just what you want. Remove parts and use the block for template in drilling panel. Switch arms and points made to work together. Price ..... **50c**

"WORKRITE RADIO PARTS WORKRITE"

**THE WORKRITE MANUFACTURING CO.**

5527 EUCLID AVE.

(Branch Office, 536 Shore Drive, Chicago)

CLEVELAND, OHIO



Troop No. 1 gets the scores at Camp Schnarr, Ossining, N. Y.

## Now for Camp with the new Portable Radiola! (Radiola II)

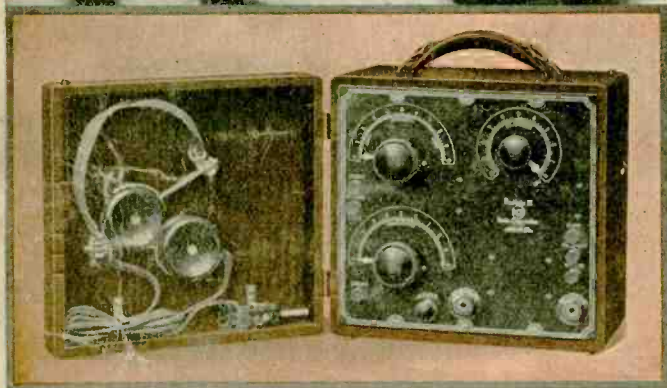

### Radiola Portable

Regenerative tuner; two tubes  
—Radiotron detector and one  
stage of audio amplification;  
all batteries and a pair of head  
receivers. \$97.50

Turn a knob—and tune in  
—mighty simple. Vernier  
attachment for fine  
tuning. Receives long  
distances with the  
headset, nearby sta-  
tions can be heard  
through a loud  
speaker.

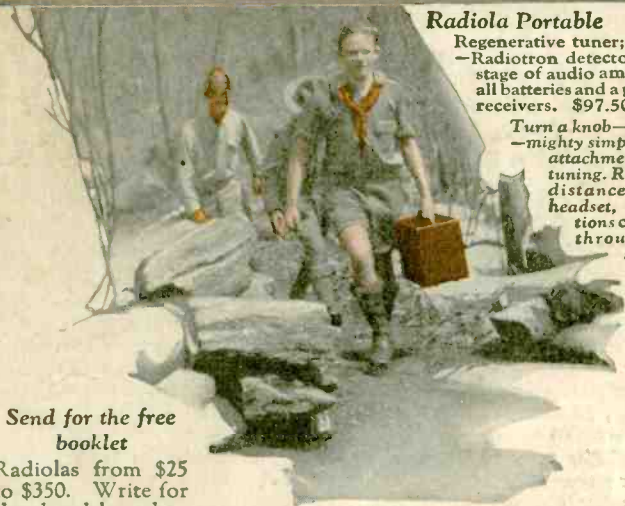

Send for the free  
booklet

Radiolas from \$25  
to \$350. Write for  
the booklet that  
tells all about 'em.

HERE'S a Radiola you can pick up and trot  
off with! In a cabinet that holds the head-  
set, the tubes, and all the batteries. With a  
handle to carry it by. Think of taking your  
Radiola with you—tuning in almost anywhere,  
at any time, on half the country's broadcast  
programs.

Now for camp life with a Radiola! Music at  
the evening campfire. Baseball scores. Songs,  
news, talks, going with you wherever you go.

Throw an insulated wire over a tree, and you  
are ready to listen in to far-away cities. Radiola  
II is a powerful receiver with two tubes. The  
secret of its smallness is the new Radiotron  
UV-199, that operates on ordinary little flash-  
light batteries!

One thing that will impress the family is the  
fine appearance of the set for home use, when  
you take off cover and handle. It's a portable  
receiver—but, first of all, it's a fine receiver,  
and a sensitive one.

*"There's a Radiola for every purse"*

at the nearest Radio or Electrical Store

RADIO CORPORATION OF AMERICA  
Dept. 2065. Address office nearest you.  
Please send me your free Radio Booklet.

This symbol  
of quality is  
your protection



Name \_\_\_\_\_

Street Address \_\_\_\_\_

City \_\_\_\_\_

R. F. D. \_\_\_\_\_

State \_\_\_\_\_

Radio Corporation of America

Sales Department  
233 Broadway  
New York

District Sales Offices  
10 So. LaSalle Street  
Chicago, Illinois

433 California Street  
San Francisco, California

# Radiola

REG. U. S. PAT. OFF.